



***Allen-Bradley***

***Remote I/O  
Adapter Module***

***(Cat. No. 1771-ASB Series E)***

**User Manual**

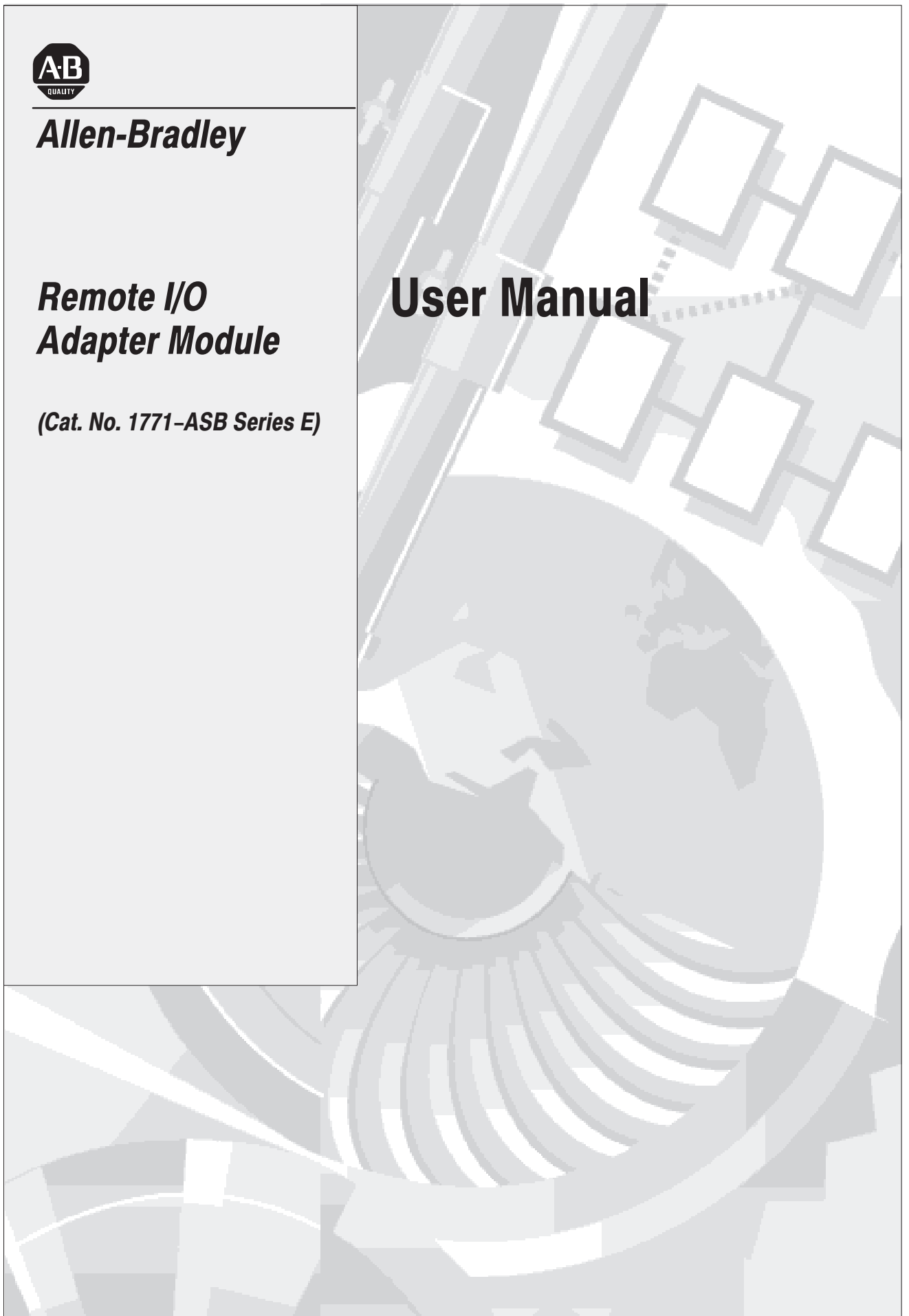

## Important User Information

Because of the variety of uses for the products described in this publication, those responsible for the application and use of this control equipment must satisfy themselves that all necessary steps have been taken to assure that each application and use meets all performance and safety requirements, including any applicable laws, regulations, codes and standards.

The illustrations, charts, sample programs and layout examples shown in this guide are intended solely for purposes of example. Since there are many variables and requirements associated with any particular installation, Allen-Bradley does not assume responsibility or liability (to include intellectual property liability) for actual use based upon the examples shown in this publication.

Allen-Bradley publication SGI-1.1, *Safety Guidelines for the Application, Installation, and Maintenance of Solid-State Control* (available from your local Allen-Bradley office), describes some important differences between solid-state equipment and electromechanical devices that should be taken into consideration when applying products such as those described in this publication.

Reproduction of the contents of this copyrighted publication, in whole or in part, without written permission of Allen-Bradley Company, Inc., is prohibited.

Throughout this manual we use notes to make you aware of safety considerations:



**ATTENTION:** Identifies information about practices or circumstances that can lead to personal injury or death, property damage or economic loss.

---

Attention statements help you to:

- identify a hazard
- avoid the hazard
- recognize the consequences

**Important:** Identifies information that is critical for successful application and understanding of the product.

## Using This Manual

### Preface Objectives

Read this preface to familiarize yourself with this manual and to learn how to use it properly and efficiently.

### What This Manual Contains

The contents of this manual are as follows:

**Table P.A**  
**What This Manual Contains**

Chapter	Title	What's Covered
1	Introducing the Remote I/O Adapter Module	Describes features, capabilities, and hardware components.
2	Installing Your Module	Procedures and guidelines for installing the module
3	Configuring Your Remote I/O	Hardware addressing and configuration options
4	Troubleshooting	Troubleshooting aids
Appendix		
A	Specifications	Module specifications
B	Settings for 1771-AS and -ASB/A, B, C and D	Comparable switch settings and keying information for older adapters
C	Differences Between 1771-ASB Series A, B, C, D and E Remote I/O Adapter Modules	An explanation of the differences between 1771-ASB Series
D	Questions and Answers	Answers to frequently asked questions
E	CSA Hazardous Location Approval	Safety approvals

### Audience

We assume that you have previously used an Allen-Bradley programmable controller, that you are familiar with its features, and that you are familiar with the terminology we use. If not, read the user manual for your processor before reading this manual.

## Understand Compliance to European Union Directives

If this product has the CE mark it is approved for installation within the European Union and EEA regions. It has been designed and tested to meet the following directives.

### EMC Directive

This product is tested to meet Council Directive 89/336/EEC Electromagnetic Compatibility (EMC) and the following standards, in whole or in part, documented in a technical construction file:

- EN 50081-2EMC – Generic Emission Standard, Part 2 – Industrial Environment
- EN 50082-2EMC – Generic Immunity Standard, Part 2 – Industrial Environment

This product is intended for use in an industrial environment.

### Low Voltage Directive

This product is tested to meet Council Directive 73/23/EEC Low Voltage, by applying the safety requirements of EN 61131-2 Programmable Controllers, Part 2 – Equipment Requirements and Tests.

For specific information required by EN 61131-2, see the appropriate sections in this publication, as well as “Industrial Automation Wiring and Grounding Guidelines For Noise Immunity,” Allen-Bradley publication 1770-4.1

Open style devices must be provided with environmental and safety protection by proper mounting in enclosures designed for specific application conditions. See NEMA Standards publication 250 and IEC publication 529, as applicable, for explanations of the degrees of protection provided by different types of enclosure.

## Terminology Used in This Manual

The following list defines common terms used in this manual.

**Complementary I/O:** An I/O technique that allows a PC to interface with an input and output module using the same location address in different I/O chassis.

**Complementary Module:** A module that performs an opposite function; an input module complements an output module and vice versa.

**Standard-Density I/O Module:** A module that provides up to 8 input terminals or 8 output terminals.

**High-Density I/O Module:** A module that provides 16 input or 16 output terminals.

**Quad-Density I/O Module:** A module that provides 32 input or 32 output terminals.

**I/O Group:** An addressing unit that can contain up to 16 input terminals and 16 output terminals.

**PC:** An Allen-Bradley programmable controller, such as the PLC-5.

**Processor:** A term used to mean an Allen-Bradley programmable controller.

**Half-Slot Addressing:** A method of addressing where the processor can address its I/O in 1/2-slot I/O groups.

**One-Slot Addressing:** A method of addressing where the processor can address its I/O in 1-slot I/O groups.

**Two-Slot Addressing:** A method of addressing where the processor can address its I/O in 2-slot I/O groups.

## Product Compatibility

The remote I/O adapter module is one of many hardware components that make up a programmable controller system. Table P.B lists the hardware components and products with which you can use the adapter module.

**Table P.B**  
**Compatible Hardware Products**

Product name	Description	Catalog number
Processors	PLC-2/20 Programmable Controller PLC-2/30 Programmable Controller PLC-3 Programmable Controller System PLC-5 Programmable Controller Family PLC-5/250 Programmable Controller (Pyramid Integrator) ControlLogix 5550 Programmable Controller Family SLC Controller Family	1772-LP1, -LP2 1772-LP3 1775-L3 1785-LT, -LT2, 6008-LTV 5250-LP 1756-L1, -L1M1, -L1M2, -L1M3 1747
I/O Scanners	Remote I/O Scanner/Distribution Panel for PLC-2 Family Processors I/O Scanner-Programmer Interface Module for PLC-3 Family Processors I/O Scanner-Message Handling Module for PLC-3 Family Processors VMEbus I/O Scanner IBM PC I/O Scanner Q-bus PC I/O Scanner Sub-I/O Scanner Pyramid Integrator Remote I/O Scanner DH+/Remote I/O Communication Interface Module Remote I/O Scanner for SLC Family Processors	1772-SD, -SD2 1775-S4A, -S5  1775-S4B, -GA 6008-SV 6008-SI 6008-SQ 1771-SN 5150-RS 1756-DHRIO 1746-SN
Universal I/O Chassis	4-slot 8-slot 12-slot 16-slot	1771-A1, -A1B 1771-A2, -A2B 1771-A3B, -A3B1 1771-A4, -A4B
I/O Modules	Block transfer modules 8-point I/O Standard density I/O modules 16-point I/O High density I/O modules 32-point I/O Quad-Density I/O modules	All modules that use the 1771 I/O structure
Adapter modules	Remote I/O Adapter Module (can mix 1771-ASB/B and 1771-AS in same remote system - limited to 115.2k Baud or less)	1771-AS
Power Supplies	System Power Supply Auxiliary Power Supply Auxiliary Power Supply module (120V AC input, 3A) Auxiliary Power Supply module (120V AC input, 8A) Redundant Power Supply module Auxiliary Power Supply module (24V DC input, 8A) Auxiliary Power Supply module (220/240V AC input, 8A) Auxiliary Power Supply module (120/220V AC input, 16A) PLC-2 Power Supply (115V AC input) PLC-2 Power Supply (24V DC input) Local Power Supply PLC-3 Power Supply Auxiliary Power Supply (24V DC input) Power Supply Module	1771-P1 1771-P2 1771-P3 1771-P4, -P4S, -P4S1 1771-P4R, -P6R 1771-P5, -P5E 1771-P6S, -P6S1 1771-PS7 1772-P1 1772-P4 1774-P1 1775-P1 1777-P4 1771-P10

## Related Publications

Read this manual in conjunction with the following documentation:

Publicatin Number	Title
1747-6.6	Remote I/O Scanner cat. no. 1747-SN User Manual
1756-6.5.14	ControlLogix Data Highway Plus/Remote I/O Communication Interface Module User Manual
1770-4.1	Programmable Controller Grounding and Wiring Guidelines
1771-2.210	Universal I/O Chassis Product Data
1772-6.6.2	PLC-2/20 and 2/30 Assembly and Installation Manual
1772-6.8.1	PLC-2/20 Programming and Operations Manual
1772-6.8.3	PLC-2/30 Programming and Operations Manual
1772-2.8	Remote I/O Scanner/Distribution Panel Product Data
1772-2.18	Remote I/O Scanner/Distribution Panel Product Data
1775-6.7.1	PLC-3 Controller Installation and Operations Manual
1775-6.3.1	PLC-3 Controller Backup Concepts Manual
1775-6.5.2	I/O Scanner-Programmer Interface Module User's Manual
1775-6.5.3	I/O Scanner-Message Handling Module User's Manual
1785-6.6.1	PLC-5 Family Assembly and Installation Manual
1789-10.1	SoftLogix Getting Results Guide
5000-6.4.7	PLC-5/250 Installing and Configuring Manual
6008-6.2.1	Q-bus I/O Scanner Module Installation Manual
6008-6.5.2	VME I/O Scanner Module User's Manual
6008-6.5.3	IBM PC I/O Scanner Module User's Manual
J2-3088-X	Automax Remote I/O Scanner Module w/Adapter Mode

## Summary

This chapter gave you information on how to use this manual efficiently. The next chapter introduces you to the remote I/O adapter module.



## Table of Contents

---

### Introducing the Remote I/O Adapter Module

#### Chapter 1

Chapter Objectives .....	1-1
Module Description and Features .....	1-1
Hardware Components .....	1-2
Diagnostic Indicators .....	1-2
Module Switch Assemblies .....	1-3
Field Wiring Arm .....	1-3
Summary .....	1-4

### Installing Your Module

#### Chapter 2

Chapter Objectives .....	2-1
Power Requirements .....	2-1
Module Location and Keying .....	2-1
Setting the Module Configuration Plugs .....	2-2
Setting the Module Switches .....	2-2
Address Switch Assembly (S1) .....	2-3
Switch Assembly (S2) .....	2-3
Setting the I/O Chassis Switches .....	2-9
Setting the Backplane Switch Assembly .....	2-9
Setting the I/O Chassis Power Supply Configuration Plug .....	2-12
Wiring the Field Wiring Arm .....	2-12
Installing the Terminator .....	2-14
Compatibility of 1771 Remote I/O Products with Extended Node Numbers .....	2-14
Module Installation .....	2-15
Summary .....	2-15

### Addressing Modes for Your Remote I/O

#### Chapter 3

Chapter Objectives .....	3-1
Hardware Addressing .....	3-1
2-Slot Addressing .....	3-3
I/O Module Combinations .....	3-3
Using Standard-density I/O (8 point) Modules .....	3-4
Using High-density (16 point) I/O Modules .....	3-5
Identifying I/O Groups .....	3-7
Complementary I/O with 2-Slot Addressing .....	3-9
Module Placement with 2-slot Addressing .....	3-11
1-Slot Addressing .....	3-13
Identifying I/O Groups .....	3-15
Module Placement with 1-slot Addressing .....	3-16
Assigning I/O Rack Numbers with 1-Slot Addressing .....	3-17
1/2- Slot Addressing .....	3-19

	Assigning I/O Rack Numbers with 1/2-slot Addressing . . . . .	3-20
	Complementary I/O with 1/2-Slot Addressing . . . . .	3-22
	Module Placement with 1/2-slot Addressing . . . . .	3-22
	Mixing 1 and 2-Slot Addressing in Individual Chassis . . . . .	3-23
	Acceptable Chassis Combinations . . . . .	3-24
	I/O Chassis/Adapter Module Combinations . . . . .	3-25
	Summary . . . . .	3-25
<b>Troubleshooting</b>	<b>Chapter 4</b>	
	Chapter Objectives . . . . .	4-1
	Troubleshooting With the Indicator Lights . . . . .	4-1
	Autoconfigure . . . . .	4-4
	Summary . . . . .	4-4
<b>Specifications</b>	<b>Appendix A</b>	
	Specifications . . . . .	A-1
<b>Settings for 1771-AS and 1771-ASB Series A, B, C and D Remote I/O Adapters</b>	<b>Appendix B</b>	
	Settings for 1771-AS and 1771-ASB Series A, B, C and D Remote I/O Adapters . . . . .	B-1
<b>Differences Between 1771-ASB Series A, B, C, D and E Remote I/O Adapter Modules</b>	<b>Appendix C</b>	
	Differences Between 1771-ASB Series A, B, C, D and E Remote I/O Adapter Modules . . . . .	C-1
<b>Questions and Answers</b>	<b>Appendix D</b>	
	Questions and Answers . . . . .	D-1
<b>CSA Hazardous Location Approval</b>	<b>Appendix E</b>	
	CSA Hazardous Location Approval . . . . .	E-1

## Introducing the Remote I/O Adapter Module

### Chapter Objectives

This chapter describes the cat. no. 1771-ASB, series E remote I/O adapter module:

- module description and features
- hardware components

### Module Description and Features

The remote I/O adapter module serves as an interface between remote I/O modules and programmable controllers. The remote I/O adapter:

- transmits data up to 10,000 cable-feet (at 57.6K baud)
- provides faster backplane scanning and data transmission up 2500 cable-feet at 230.4K baud
- receives/sends data from/to the I/O scanner in serial form
- reads/writes data from/to the input modules in parallel form
- reads/writes data from/to the output modules in parallel form
- supports any mix of I/O (4, 6, 8, 16 or 32 points)
- supports three methods of I/O addressing; 1/2-slot, 1-slot and 2-slot
- checks I/O configuration on power-up to verify I/O module placement
- scans all slots in the chassis, or all but the last four slots, allowing improved scan time and I/O image space savings. Slot power supplies can be used in the last quarter of the rack without using I/O space.
- can emulate series B adapters, providing system response similar to the 1771-ASB series B. This allows use of 1771-S4A and -S4B scanners which require slower response for proper operation.
- has enhanced diagnostic indicators for easier troubleshooting.

## Hardware Components

The remote I/O adapter module consists of four major components:

- diagnostic indicators
- module switch assemblies
- field wiring arm

### Diagnostic Indicators

Diagnostic indicators are located on the front panel of the adapter module (Figure 1.1). They show both normal operation and error conditions in your remote I/O system. The indicators are:

- ACTIVE (green)
- ADAPTER FAULT (red)
- I/O RACK FAULT (red)

A complete description of these indicators and how to use them for troubleshooting is explained in chapter 4.

**Figure 1.1**  
Remote I/O Adapter Module, Cat. No. 1771-ASB Series E

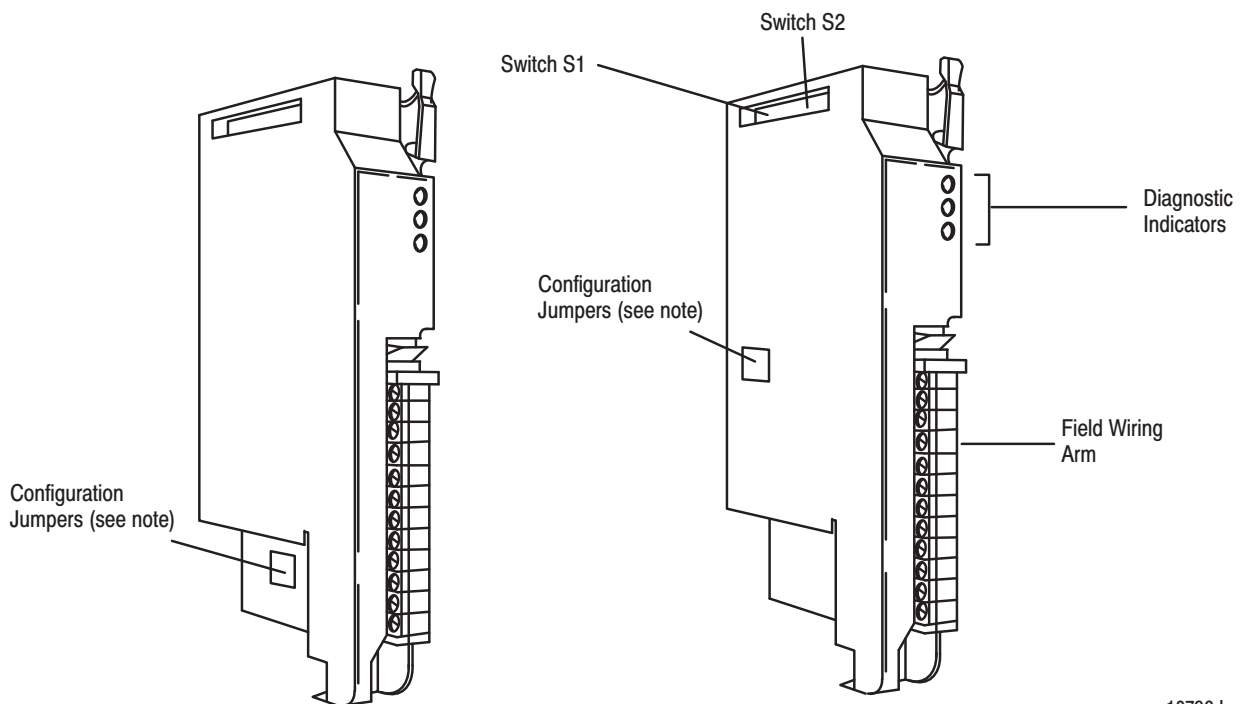

10796-I

NOTE: Configuration jumpers may be in either position, depending upon production date.

## Module Switch Assemblies

You must set two switch assemblies to configure your adapter module. Figure 1.2 shows the location of the switches.

**Figure 1.2**  
Switch Locations

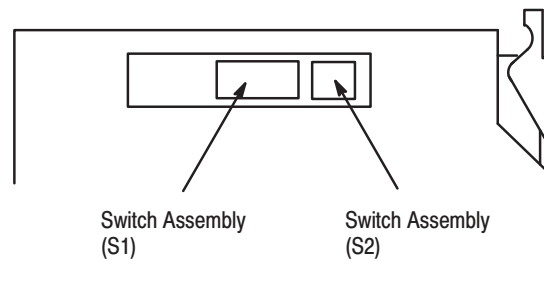

The **S1** Assembly is used to select:

- the I/O rack number
- the first I/O group number
- I/O scanner communication with or without complementary I/O (for PLC-2 family processors)

The **S2** Switch Assembly selects:

- a specific baud rate based on the maximum I/O chassis distance
- I/O scanner communication with or without complementary I/O (for PLC-2 family processors)
- scan - processor will scan all slots in the chassis, or all but the last four slots in the chassis
- link response - establishes series B emulation response time required for compatibility with PLC-2 and PLC-3 scanners.

## Field Wiring Arm

The field wiring arm (cat. no. 1771-WB) provides connection points for:

- I/O communication cables
- a user-supplied I/O chassis restart pushbutton

The field wiring arm (Figure 1.1) pivots on the front of the chassis to connect with the module's printed circuit board. This feature allows you to remove the adapter module without disconnecting the system wiring.

**Summary**

In this chapter we discussed the functions and hardware components of the Remote I/O Adapter Module.

## Installing Your Module

### Chapter Objectives

This chapter describes the procedures for installing your remote I/O adapter module. These include:

- power requirements
- module location and keying
- setting configuration plugs
- setting the module switches
- setting the I/O chassis switches (backplane and
- setting the I/O chassis power supply configuration plug
- wiring the field wiring arm
- installing the terminator resistor
- compatibility of products
- installing the module

### Power Requirements

The remote I/O adapter module requires a backplane current of 1.0A at 5V dc. Remember to add this amount to other current requirements for your remote I/O chassis.

### Module Location and Keying

The remote I/O adapter module must be installed in the leftmost slot of the I/O chassis.

The I/O chassis backplane connectors are keyed to accept only one type of module. This prevents accidental insertion of other modules in the wrong module slot. Key the backplane connectors (Figure 2.1) for the adapter module as follows:

- upper connector: between 54 and 56
- lower connector: between 16 and 18

**Figure 2.1**  
Keying Diagram

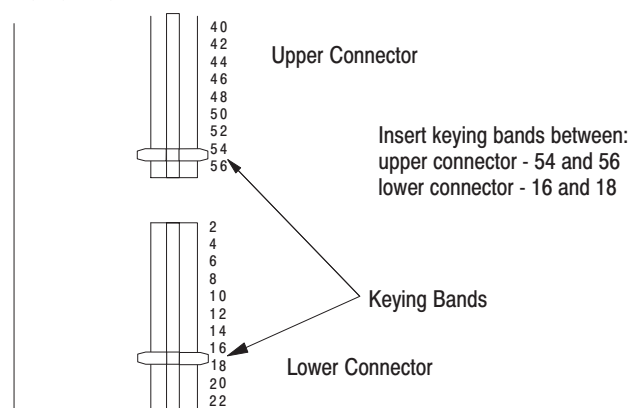

12252

## Setting the Module Configuration Plugs

You need to set configuration plugs on the remote I/O adapter module to use 32-point I/O modules. You access the plugs through the access hole on the left side of the module (Figure 2.2). Each plug is inserted on two pins of a three-pin connector. Thermocouple Input Modules (Cat. No. 1771-IX and -IY) are not compatible with 32-point I/O modules.

**Figure 2.2**  
Setting the Module Configuration Plug

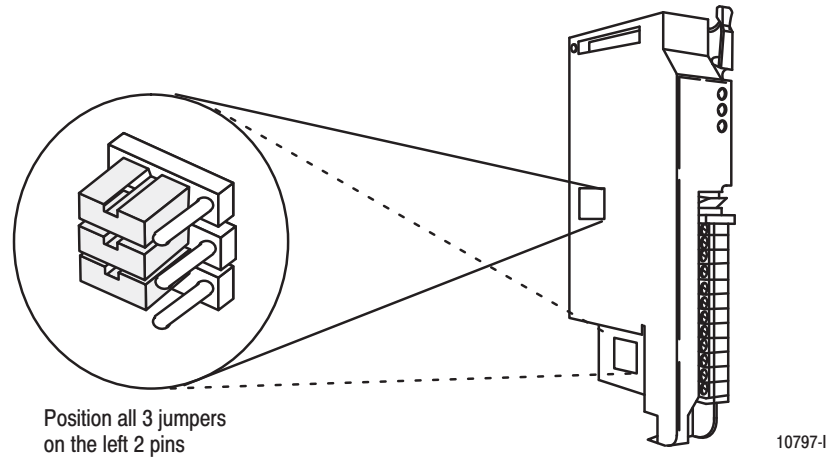

NOTE: Configuration jumpers may be in either position, depending upon production date.

**Important:** When you set the configuration plugs in the left position, you can use 32-point I/O modules and any addressing method, but you cannot use Cat. No. 1771-IX or 1771-IY modules. When you set these plugs in the right position, you can use 1771-IX and 1771-IY modules and any addressing method, but you cannot use 32-point I/O modules. If the plugs are set incorrectly, addressing errors will occur.

If you need to use a thermocouple module and 32-point I/O modules in the same remote chassis, use the 1771-IXE Thermocouple/Millivolt Module (Cat. No. 1771-IXE).

## Setting the Module Switches

Set switch assemblies S1 and S2 (Figure 2.3) with a blunt, pointed instrument such as a ball-point pen. Do **not** use a pencil; the lead could break off and jam the switch.

This publication describes switches as being either on or off. The words ON and OFF should be printed on the switch assemblies. If a switch assembly has the word OPEN printed on it, the word OPEN corresponds to OFF.

**Figure 2.3**  
**S1 and S2 Switch Assembly Locations**

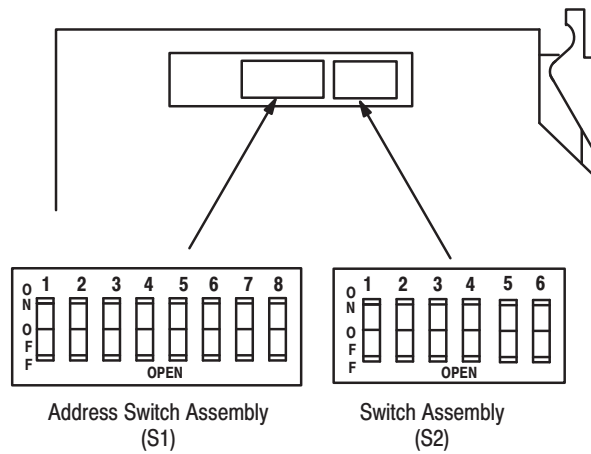

### Address Switch Assembly (S1)

You use this switch assembly to select:

- the **I/O rack** number
- the **first I/O group** number
- **primary/complementary** – I/O scanner communication with or without complementary I/O (for PLC-2 and PLC-5 family processors)

### Switch Assembly (S2)

You use this switch assembly to select:

- **baud** – a specific baud rate based on the maximum I/O chassis distance
- **primary/complementary** – I/O scanner communication with or without complementary I/O (for PLC-2 family processors)
- **scan** - select whether the processor will scan all slots in the chassis, or all but the last four slots in the chassis

- **link response** - unrestricted or series B emulation.  
Certain scanner modules with multiple communication ports require a delay in the link turnaround time to allow the central processing unit (CPU) in the scanner sufficient time to service all communication ports. Without this delay, some incoming information may be missed while the scanner is servicing another port. This results in multiple communication retries. To provide the necessary delay, set the link response switch (position 5, switch S2) to the **ON** position.

Scanner modules which **require** a delay are:

Programmable Controller	Scanner Module
PLC-2	1772-SD2
PLC-3	1775-S4A
	1775-S4B
	1775-S5
PLC-3/10	1775-SR5
	1775-SR

- **noise immunity** – enables backplane retries to occur when noise is detected on the I/O rack backplane. This feature is enabled when the switch is **off**. Do not use this switch position as a substitute for improper noise suppression.

Refer to the Table below for Figure and page numbers of switch settings for each processor family.

S1 and S2 Switch Settings for:	Refer to:
PLC-2 family processor	Figure 2.4, page 2-5
PLC-3 family processor	Figure 2.5, page 2-6
PLC-5 family, SLC and ControlLogix processors without complementary I/O	Figure 2.6, page 2-7
PLC-5 family, SLC and ControlLogix processor with complementary I/O	Figure 2.7, page 2-8

**Figure 2.4**  
**Module Switch Assembly Settings for PLC-2 Family**  
**Processors**

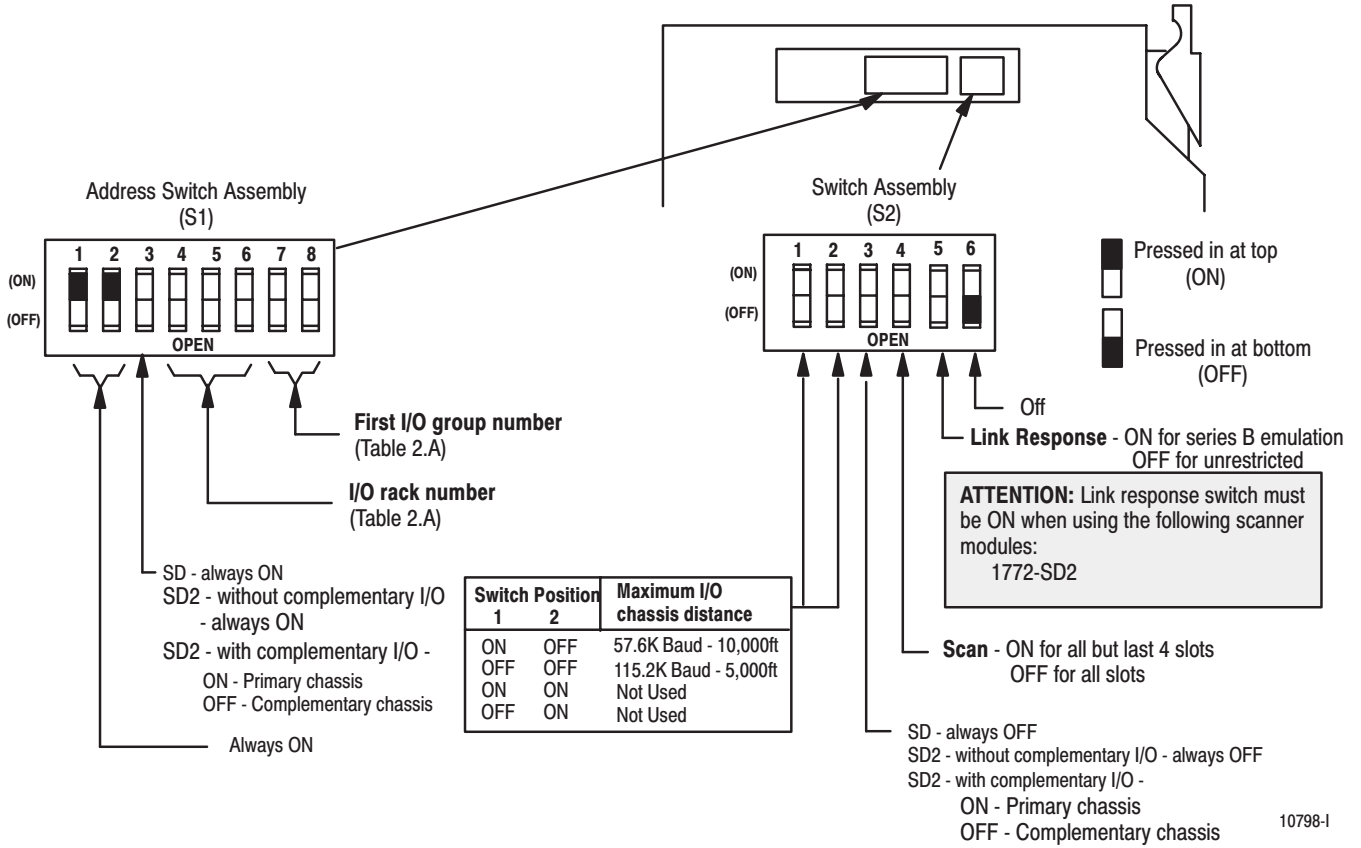
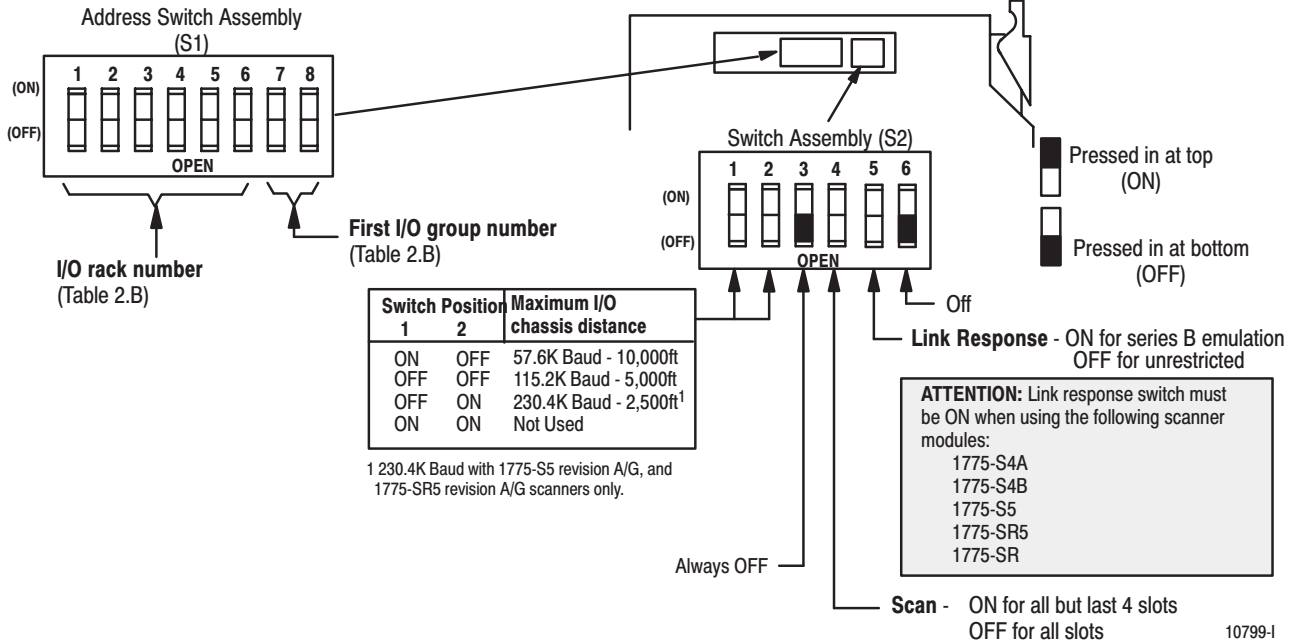

**Table 2.A**  
**I/O Rack Number and First I/O Group Switch Selections for**  
**the Address Switch Assembly S1 (PLC-2 Family**  
**Processors)**

I/O Rack Number	Switch Selections			First I/O Group Number	Switch Selections	
	4	5	6		7	8
1	On	On	On	0	On	On
2	On	On	Off	2	On	Off
3	On	Off	On	4	Off	On
4	On	Off	Off	6	Off	Off
5	Off	On	On			
6	Off	On	Off			
7	Off	Off	On			

10798-1

**Figure 2.5**  
Module Switch Assembly Settings for PLC-3 Family Processors



**Table 2.B**  
I/O Rack Switch Selections for the Address Switch Assembly (PLC-3 Family Processors)

Rack #	Switch Setting						Rack #	Switch Setting						Rack #	Switch Setting						Rack #	Switch Setting								
	1	2	3	4	5	6		1	2	3	4	5	6		1	2	3	4	5	6		1	2	3	4	5	6			
00	On	On	On	On	On	On	20	On	Off	On	On	On	On	40	Off	On	On	On	On	On	60	Off	Off	On	On	On	On			
01	On	On	On	On	On	Off	21	On	Off	On	On	On	Off	41	Off	On	On	On	On	Off	61	Off	Off	On	On	On	Off			
02	On	On	On	On	Off	On	22	On	Off	On	On	Off	On	42	Off	On	On	On	Off	On	62	Off	Off	On	On	Off	On			
03	On	On	On	On	Off	Off	23	On	Off	On	On	Off	Off	43	Off	On	On	On	Off	Off	63	Off	Off	On	On	Off	Off			
04	On	On	On	Off	On	On	24	On	Off	On	Off	On	On	44	Of	On	On	Off	On	On	64	Off	Off	On	Off	On	On			
05	On	On	On	Off	On	Off	25	On	Off	On	Off	On	Off	45	Off	On	On	Off	On	Off	65	Off	Off	On	Off	On	Off			
06	On	On	On	Off	Off	On	26	On	Off	On	Off	Off	On	46	Off	On	On	Off	Off	On	66	Off	Off	On	Off	Off	On			
07	On	On	On	Off	Off	Off	27	On	Off	On	Off	Off	Off	47	Off	On	On	Off	Off	Off	67	Off	Off	On	Off	Off	Off			
10	On	On	Off	On	On	On	30	On	Off	Off	On	On	On	50	Off	On	Off	On	On	On	70	Off	Off	Off	On	On	On			
11	On	On	Off	On	On	Off	31	On	Off	Off	On	On	Off	51	Off	On	Off	On	On	Off	71	Off	Off	Off	On	On	Off			
12	On	On	Off	On	Off	On	32	On	Off	Off	On	Off	On	52	Off	On	Off	On	Off	On	72	Off	Off	Off	On	Off	On			
13	On	On	Off	On	Off	Off	33	On	Off	Off	On	Off	Off	53	Off	On	Off	On	Off	Off	73	Off	Off	Off	On	Off	Off			
14	On	On	Off	Off	On	On	34	On	Off	Off	Off	On	On	54	Off	On	Off	Off	On	On	74	Off	Off	Off	Off	On	On			
15	On	On	Off	Off	On	Off	35	On	Off	Off	Off	On	Off	55	Off	On	Off	Off	On	Off	75	Off	Off	Off	Off	On	Off			
16	On	On	Off	Off	Off	On	36	On	Off	Off	Off	Off	On	56	Off	On	Off	Off	Off	On	76	Off	Off	Off	Off	Off	On			
17	On	On	Off	Off	Off	Off	37	On	Off	Off	Off	Off	Off	57	Off	On	Off	Off	Off	Off	77	Not valid								
<b>1st I/O Group Number</b>	<b>Switch Selections</b>						Note: Rack address 77 is an illegal configuration. PLC-3 processors can scan racks 0-76.																							
	<b>7</b>						<b>8</b>																							
0	On						On																							
2	On						Off																							
4	Off						On																							
6	Off						Off																							

**Figure 2.6**  
**Module Switch Assembly Settings for PLC-5 Family, SLC**  
**and ControlLogix Processors Without Complementary I/O**

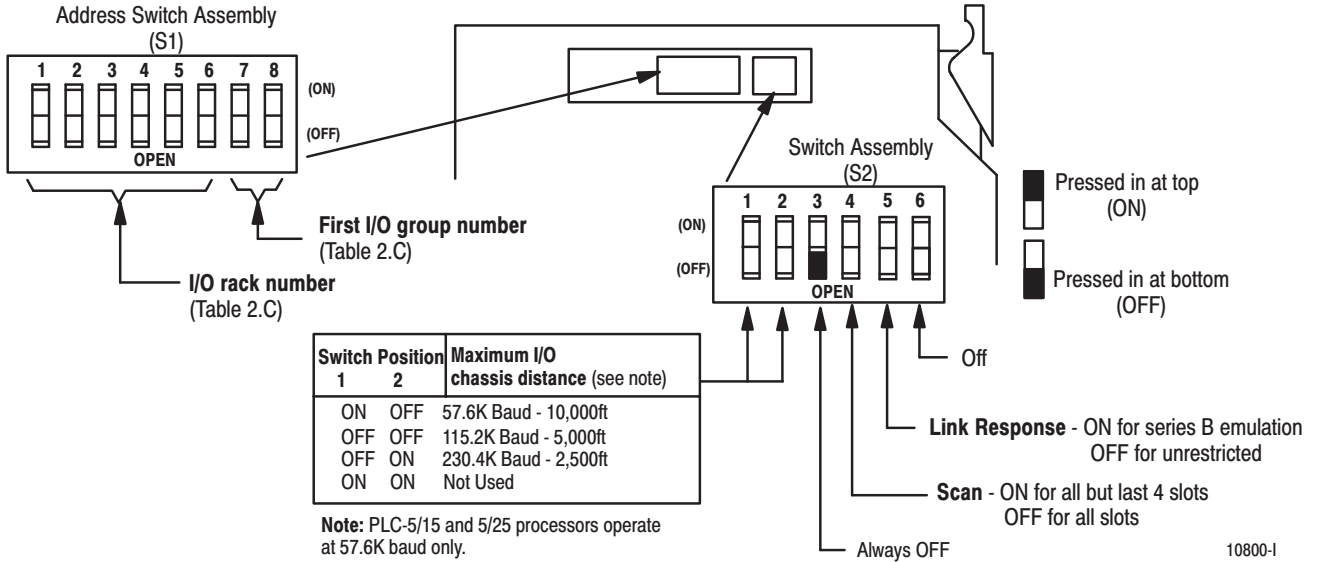
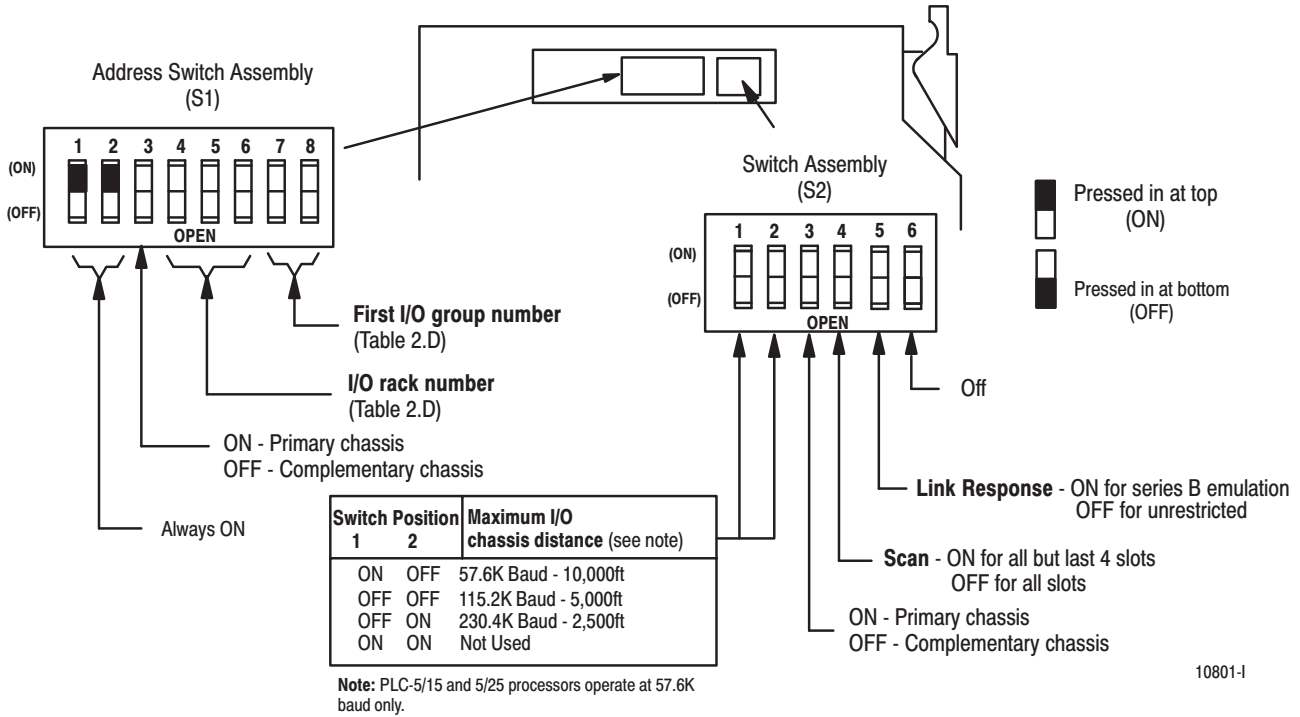

**Table 2.C**  
**I/O Rack Selection for PLC-5 Family Processors**  
**without Complementary I/O**

Rack #	Switch Setting						Rack #	Switch Setting						1st I/O Group Number	Switch Selections	
	1	2	3	4	5	6		1	2	3	4	5	6		7	8
00	On	On	On	On	On	On	20	On	Off	On	On	On	On	0	On	On
01	On	On	On	On	On	Off	21	On	Off	On	On	On	Off	2	On	Off
02	On	On	On	On	Off	On	22	On	Off	On	On	Off	On	4	Off	On
03	On	On	On	On	Off	Off	23	On	Off	On	On	Off	Off	6	Off	Off
04	On	On	On	Off	On	On	24	On	Off	On	Off	On	On			
05	On	On	On	Off	On	Off	25	On	Off	On	Off	On	Off			
06	On	On	On	Off	Off	On	26	On	Off	On	Off	Off	On			
07	On	On	On	Off	Off	Off	27	On	Off	On	Off	Off	Off			
10	On	On	Off	On	On	On	30	On	Off	Off	On	On	On			
11	On	On	Off	On	On	Off	31	On	Off	Off	On	On	Off			
12	On	On	Off	On	Off	On	32	On	Off	Off	On	Off	On			
13	On	On	Off	On	Off	Off	33	On	Off	Off	On	Off	Off			
14	On	On	Off	Off	On	On	34	On	Off	Off	Off	On	On			
15	On	On	Off	Off	On	Off	35	On	Off	Off	Off	On	Off			
16	On	On	Off	Off	Off	On	36	On	Off	Off	Off	Off	On			
17	On	On	Off	Off	Off	Off	37	On	Off	Off	Off	Off	Off			

PLC-5/11 processors can scan rack 03.  
 PLC-5/15 and PLC-5/20 processors can scan racks 01-03.  
 PLC-5/25 and PLC-5/30 processors can scan racks 01-07.  
 PLC-5/40 and PLC-5/40L processors can scan racks 01-17.  
 PLC-5/60 and PLC-5/60L processors can scan racks 01-27.  
 PLC-5/250 processors can scan racks 0-37.

**Figure 2.7**  
**Module Switch Assembly Settings for PLC-5 Family, SLC**  
**and ControlLogix Processors With Complementary I/O**



10801-1

**Table 2.D**  
**I/O Rack Selection for PLC-5 Family Processors with**  
**Complementary I/O**

I/O Rack #	Switch						1st I/O Group Number	Switch Selections	
	1	2	3	4	5	6		7	8
01	On	On	On	On	On	Off	0	On	On
02	On	On	On	On	Off	On	2	On	Off
03	On	On	On	On	Off	Off	4	Off	On
							6	Off	Off
04	On	On	On	Off	On	On			
05	On	On	On	Off	On	Off			
06	On	On	On	Off	Off	On			
07	On	On	On	Off	Off	Off			
See note below									

**Note:** PLC-5/11 can scan rack 03.  
 PLC-5/20, PLC-5/30, PLC-5/40, PLC-5/60 can scan racks 01-07.

## Setting the I/O Chassis Switches

After setting the adapter module switch assemblies, you must also

- set the I/O chassis backplane switches

### Setting the Backplane Switch Assembly

The backplane switch assembly is located on the backplane of the I/O chassis. You use it to select:

- the last state of all outputs
- the processor restart lockout feature
- 1/2-, 1- or 2-slot addressing
- the last chassis in the I/O system (for PLC-2 family processors)

Refer to the table below for backplane switch setting illustrations for the various processors.

For Processor:	Refer to:
PLC-2	Figure 2.8, page 2-9
PLC-3	Figure 2.9, page 2-10
PLC-5	Figure 2.10, page 2-10
PLC-5 remote configuration	Figure 2.11, page 2-11
PLC-5/250	Figure 2.12, page 2-11

**Figure 2.8**  
I/O Chassis Backplane Switch Assembly Settings for Remote Adapter Module in PLC-2 Family Processor System

#### Last State Switch -

When ON, outputs of this chassis remain in last state.  
When OFF, outputs of this I/O chassis are deenergized when a fault is detected.

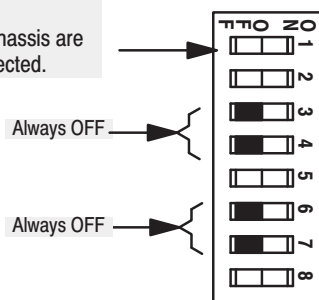

#### Processor Restart Lockout -

When ON, processor can restart I/O chassis  
When OFF, I/O chassis must be restarted at the chassis.

#### Addressing Switch -

ON - 1-slot addressing selected  
OFF - 2-slot addressing selected

#### Last Chassis Switch -

ON - Chassis does not contain the highest numbered I/O group for the associated rack number  
OFF - Chassis does contain the highest numbered I/O group for the associated rack number

- If you have only a primary chassis, set this switch to OFF.
- If you have both primary and complementary chassis, set the primary chassis to ON and the complementary chassis to OFF.

**ATTENTION:** Set switch 1 to the OFF position to deenergize outputs wired to this chassis when a fault is detected. If switch 1 is set to the ON position, outputs connected to this chassis remain in their last state when a fault occurs and machine motion may continue after fault detection.

**Figure 2.9**  
I/O Chassis Backplane Switch Assembly Settings for Remote Adapter Module in PLC-3 Family Processor System

**ATTENTION:** Set switch 1 to the **OFF** position to deenergize outputs wired to this chassis when a fault is detected. If switch 1 is set to the **ON** position, outputs connected to this chassis remain in their last state when a fault occurs and machine motion may continue after fault detection.

**Last State Switch -**  
When **ON**, outputs of this chassis remain in last state.  
When **OFF**, outputs of this I/O chassis are deenergized when a fault is detected.

**Processor Restart Lockout -**  
When **ON**, processor can restart I/O chassis  
When **OFF**, I/O chassis must be restarted at the chassis.

Always OFF

1771-A1/A1B chassis in PLC-3 Backup  
**ON** - If any 1771-A1/A1B chassis contains starting I/O group 0 with 2-slot addressing and the PLC-3 is configured in backup mode.  
**OFF** - All other times.

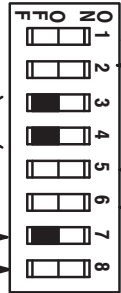

Addressing Switches		
5	6	
OFF	ON	You select 1/2-slot addressing
ON	OFF	You select 1-slot addressing
OFF	OFF	You select 2-slot addressing
ON	ON	Not allowed

10802-1

**Figure 2.10**  
I/O Chassis Backplane Switch Assembly Settings for Remote Adapter Module in PLC-5 Family Processor System

**ATTENTION:** Set switch 1 to the **OFF** position to deenergize outputs wired to this chassis when a fault is detected. If switch 1 is set to the **ON** position, outputs connected to this chassis remain in their last state when a fault occurs and machine motion may continue after fault detection.

**Last State Switch -**  
When **ON**, outputs of this chassis remain in last state.  
When **OFF**, outputs of this I/O chassis are deenergized when a fault is detected.

**Processor Restart Lockout -**  
When **ON**, processor can restart I/O chassis  
When **OFF**, I/O chassis must be restarted at the chassis.

Always OFF

**Last Chassis Switch -**  
ON - Chassis does not contain the highest numbered I/O group for the associated rack number  
OFF - Chassis does contain the highest numbered I/O group for the associated rack number

- If you have only a primary chassis, set this switch to OFF.
- If you have both primary and complementary chassis, set the primary chassis to ON and the complementary chassis to OFF.

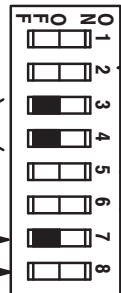

Addressing Switches		
5	6	
OFF	ON	You select 1/2-slot addressing
ON	OFF	You select 1-slot addressing
OFF	OFF	You select 2-slot addressing
ON	ON	Not allowed

10802-1

**Figure 2.11**  
**I/O Chassis Backplane Switch Assembly Settings for Remote Adapter Module in PLC-5 Family, SLC and ControlLogix Processor Systems in Remote Configuration**

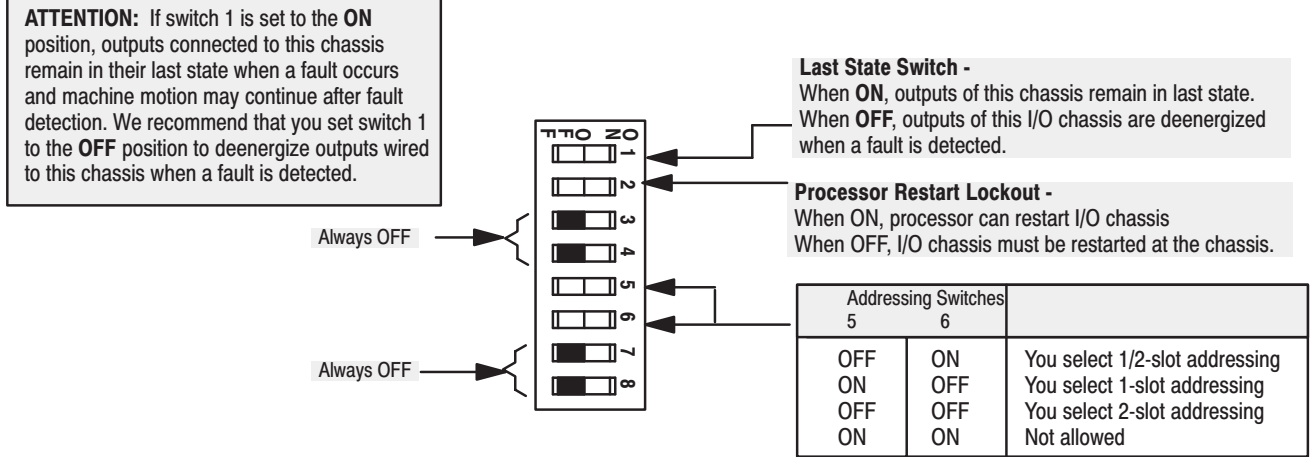

10802-1

**Figure 2.12**  
**I/O Chassis Backplane Switch Assembly Settings for Remote Adapter Module in PLC-5/250 Processor System**

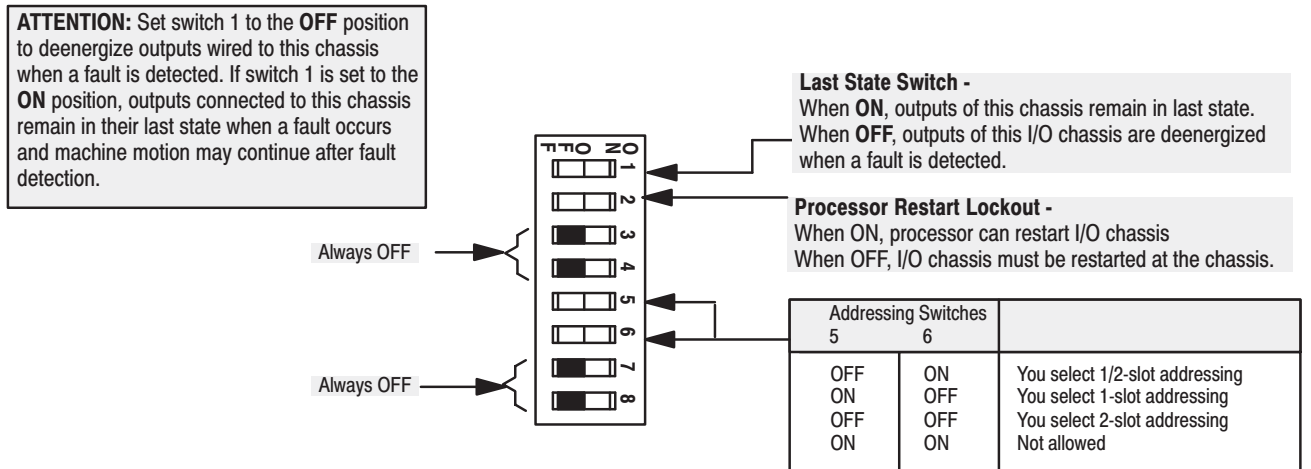



10802-1

## Setting the I/O Chassis Power Supply Configuration Plug

You use the I/O chassis power-supply configuration plug (Figure 2.13) to identify the type of power supply you use with your remote chassis. This configuration plug is located on the backplane of series B I/O chassis.

**Figure 2.13**  
Series B I/O Chassis Power Supply Configuration Plug Settings

For Use With:	Set Chassis Configuration Plug to:
power supply module installed in chassis	"Y" position 
external power supply in your remote system	"N" position 

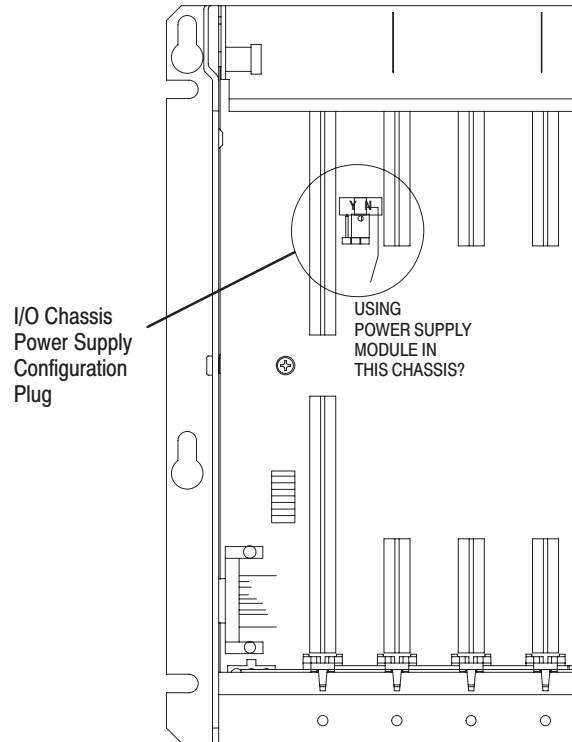

## Wiring the Field Wiring Arm

The field wiring arm provides connection points for:

- I/O communication cables
- a user-supplied I/O chassis restart pushbutton

The wiring arm pivots on the front of the chassis to connect with the module's printed circuit board, allowing you to remove the adapter module without disconnecting the system wiring.

Connect input/output cables to the field wiring arm as shown in Figure 2.14.

**Figure 2.14**  
**Field Wiring Arm Connection Diagram for the 1771-ASB Series E**

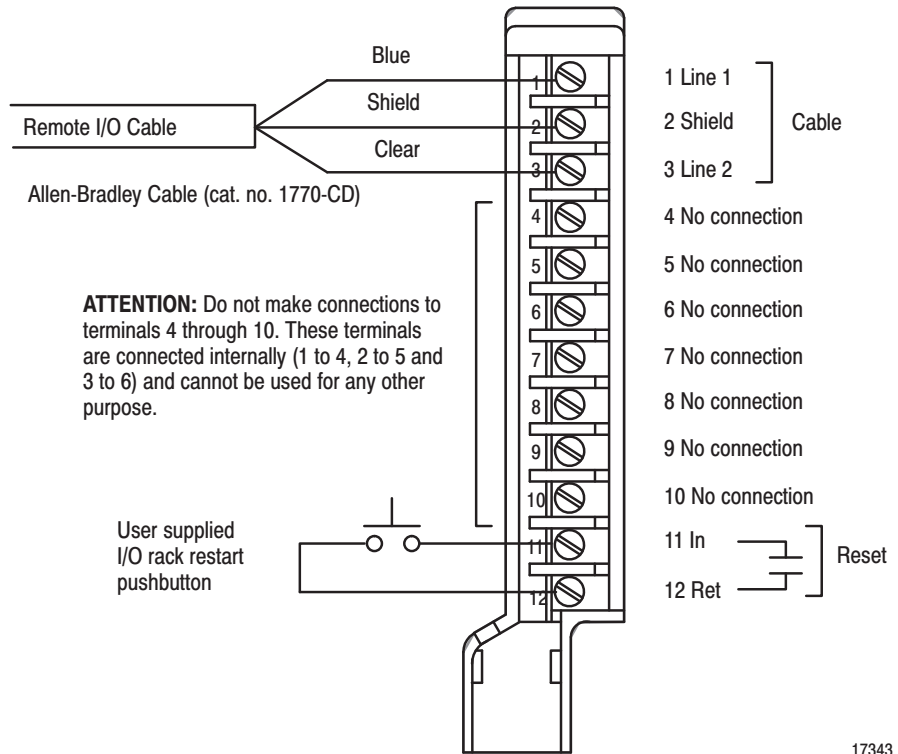

17343



**ATTENTION:** Do not remove or insert the adapter module from the I/O chassis while system power is on. Otherwise, you may damage module circuitry.

Terminals 1 and 4, 2 and 5, and 3 and 6 are internally connected on the module. If you use these terminals (4, 5, and 6) for connection of additional adapter modules, you disconnect the remaining adapter modules in the series connection when you disconnect the remote I/O adapter module wiring arm. If this is unsuitable for your application, make your connections to terminals 1, 2, and 3 only.

## Installing the Terminator

If this is the last remote I/O adapter on the link, you must use a terminating resistor to terminate both ends of the remote I/O link (scanner end and last adapter end). Connect the terminator across terminals 1 (blue) and 3 (clear).

The size of the terminator is determined by the system configuration. Older configurations use a 150 ohm resistor at both ends. With newer products that can support it, you can use an 82 ohm terminator at both ends. The 82 ohm terminators provide “extended node” capability which allows you to have up to 32 physical devices on the RIO link. (The number of logical racks capable of being addressed by the scanner is not affected.) This allows 1/4, 1/2 and 3/4 racks, Dataliners, Redipanel and Panelview devices to be attached to the link.



**ATTENTION:** Devices that are operating at 230.4K Baud must have 82 ohm terminators in place for proper operation.

## Compatibility of 1771 Remote I/O Products with Extended Node Numbers

Certain products are not compatible with the extended node capabilities obtained with the use of the 82 ohm terminator resistors. These products are listed below.

**Table 2.E**  
**Non-compatible Products**

Device	Series
Scanners - 1771-SN	All
1771-SD	All
1772-SD2	All
1775-SR	All
1775-S4A	All
1775-S4B	All
Adapters - 1771-AS	All
1771-ASB	Series A
1771-DCM	All
Miscellaneous - 1771-AF	All
1771-AF1	All

## Module Installation

Once you've determined the power requirements, keying, and wiring for your adapter module, and have set the appropriate switch assemblies, you can use the following procedure to install it.

Refer to the Industrial Automation Wiring and Grounding Guidelines for Noise Immunity (publication 1770-4.1) for proper grounding and wiring methods to use when installing your module.



**ATTENTION:** Remove system power before removing or installing your module in the I/O chassis. Failure to observe this warning could damage module circuitry and injure people.

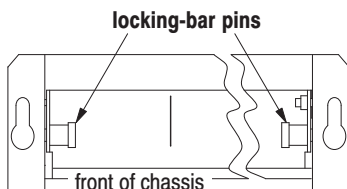

12453-I

1. Remove power from the I/O chassis before inserting (or removing) the module.
2. On chassis equipped with a chassis locking bar, pull the locking-bar pins to release the locking bar and swing it up.
3. Insert the module into slot.
4. Place the module in the plastic tracks on the top and bottom of the leftmost slot. These slots guide the module into position.
5. Press firmly and evenly to seat the module in its backplane connectors.



**ATTENTION:** Do not force the module into the backplane connector. If you cannot seat the module with firm pressure, check the alignment and keying. Forcing the module can damage the backplane connector or the module.

6. Snap the chassis locking bar (or locking latch on earlier chassis) over the top of the module to secure it. Make sure the locking pins on the locking bar are fully engaged.
 

**Note:** The chassis locking bar will not close if all modules are not properly seated.
7. Swing field wiring arm up into place and press firmly until it latches.
8. Reapply system power and check for proper operation.

## Summary

In this chapter you learned how to install your adapter module. Chapter 3 tells you how to configure your module.



## Addressing Modes for Your Remote I/O

### Chapter Objectives

When you configure your remote I/O system, you must consider:

- how to address your I/O
- what combination of I/O modules and I/O chassis you can use

These topics are discussed in this chapter.

### Hardware Addressing

Programmable controllers that use the 1771-ASB remote I/O adapter module can address their I/O in 2-slot, 1-slot or 1/2 slot I/O groups. These three addressing methods are referred to as 2-slot addressing, 1-slot addressing and 1/2-slot addressing.

You select the addressing method with switch 5 and 6 in the I/O chassis backplane switch assembly. You make this selection for each chassis independently with only one method of addressing for each chassis.

I/O groups are made up of I/O terminals (Figure 3.1). An I/O group is an addressing unit that can contain up to 16 input terminals and 16 output terminals. You select an I/O chassis to have either 2-slot, 1-slot or 1/2-slot I/O groups.

**Figure 3.1**  
**An I/O Group - Up to 16 Input Terminals and 16 Output Terminals**

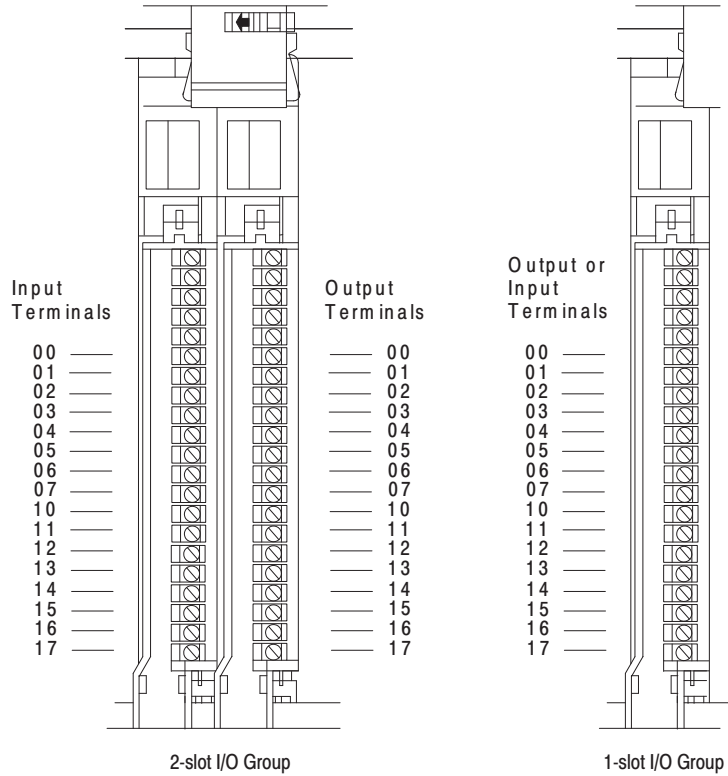

13073

I/O racks are made up of I/O groups (Figure 3.1). An I/O rack is an addressing unit that can contain up to eight I/O groups.

**Figure 3.2**  
**An I/O Rack - Up to Eight I/O Groups**

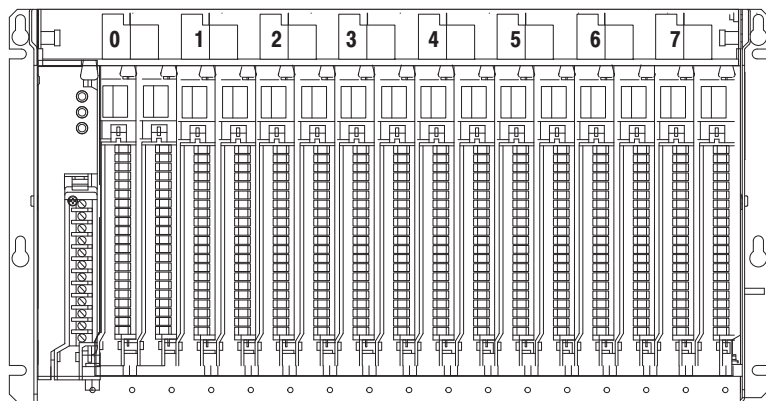

13074

## 2-Slot Addressing

*Definition:* The processor addresses two I/O module slots as one I/O group.

*Concept:* Each physical 2-slot I/O group is represented by a word in the input image table and a word in the output image table. Each input terminal corresponds to a bit in the input image table word and each output terminal corresponds to a bit in the output image table word.

The maximum number of bits available for one 2-slot I/O group is 32: 16 bits in the input image table and 16 bits in the output image table. The type of module you install (either 8 or 16-point I/O) determines the number of bits in the words that are used.

You select 2-slot addressing by setting switches 5 and 6 of the I/O chassis backplane switch assembly to the OFF position.

### I/O Module Combinations

The combination of I/O modules you can use depends on the addressing method and I/O chassis you select.

Table 3.A lists acceptable I/O module combinations with 2-slot addressing.

**Table 3.A**  
I/O Module Combinations With 2-slot Addressing

I/O Chassis Series	I/O Module Combinations Per I/O Group	Data Table Bits Used	
		Input Image Table	Output Image Table
A, B	2 8-point input modules	16	0
	2 8-point output modules	0	16
	1 8-point input and output module	8	8
	1 8-point input and 1 block transfer output module	16	8
	1 block transfer and 1 8-point output module	8	16
	2 block transfer modules	16	16
B or later only	1 16-point input and output module	16	16
	1 16-point and 1 8-point output module	16	8
	1 8-point input and 1 16-point output module	8	16

### Using Standard-density I/O (8 point) Modules

Standard-density I/O modules provide eight input terminals or eight output terminals. Figure 3.3 illustrates the 2-slot I/O group concept with two 8-point input modules. Figure 3.4 shows an 8-point input module and an 8-point output module in a 2-slot I/O group.

**Figure 3.3**  
**Two 8-point Input Modules Using One Word of the Input Image Table**

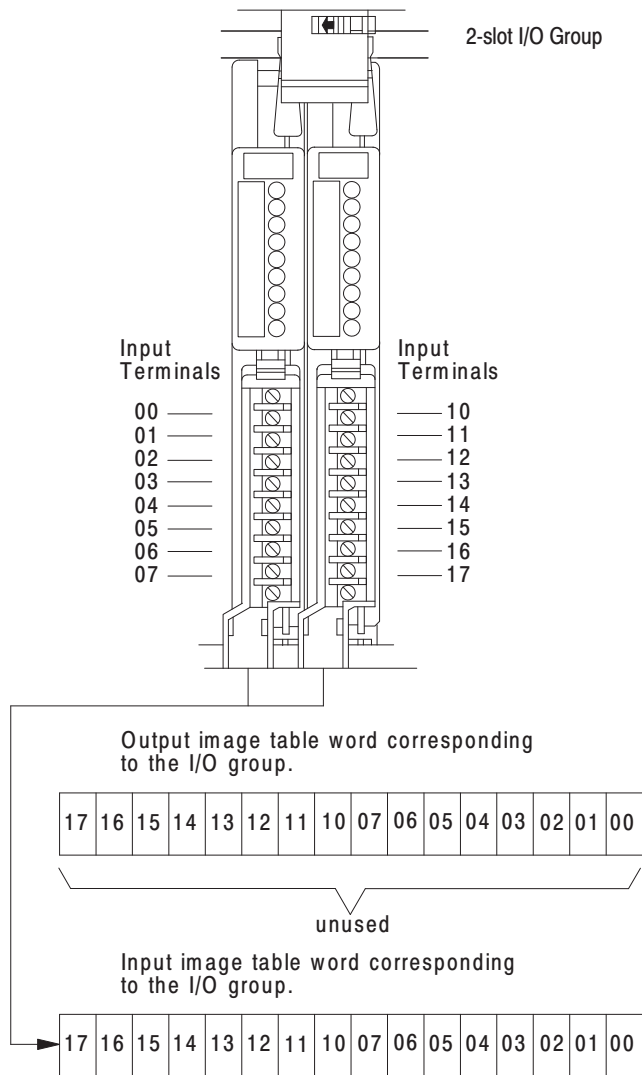

11867

**Figure 3.4**  
**8-point Input and Output Modules Using Eight Bits of the**  
**Input Image Table Word and Eight Bits of the Output Image**  
**Table Word**

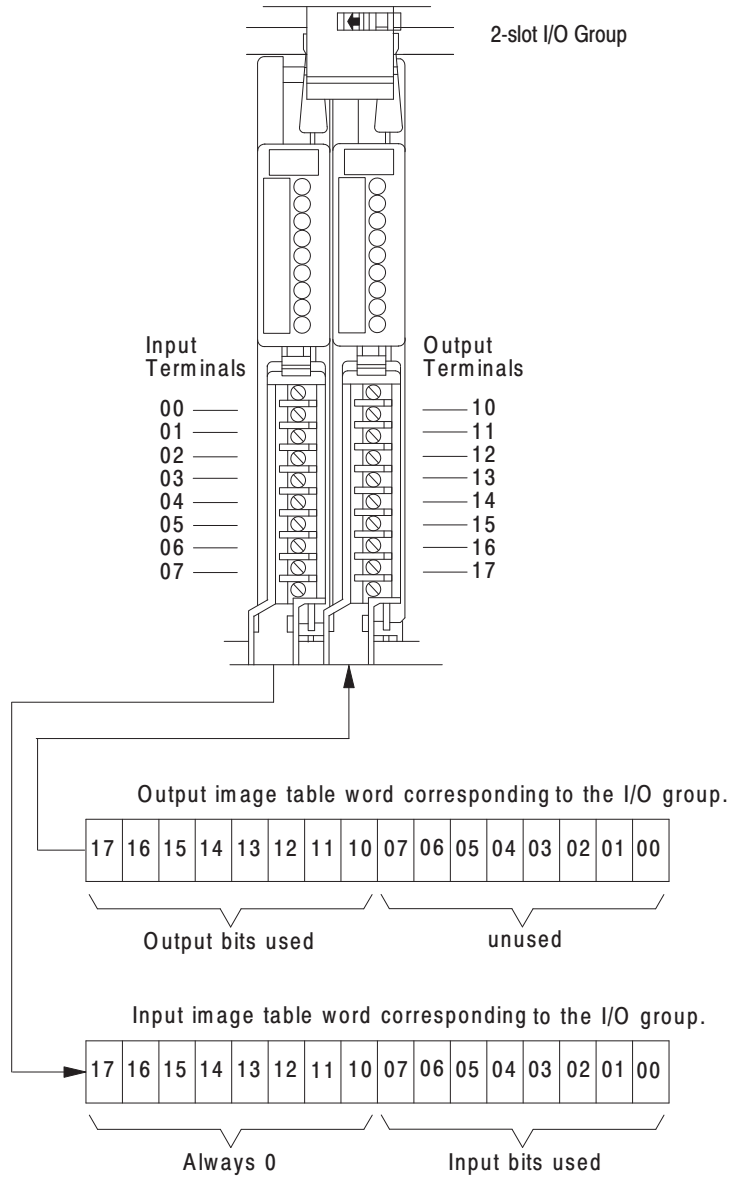

14965

### Using High-density (16 point) I/O Modules

16-point I/O modules provide 16 input terminals or 16 output terminals. 16-point I/O modules use a full word in the input or output image table when they are addressed as a 2-slot I/O group (Figure 3.5). Two 16-point modules (one input and one output) can be used in a 2-slot I/O group.

**Figure 3.5**  
**16-point Input and Output Modules Using Two Words of the**  
**Image Table**

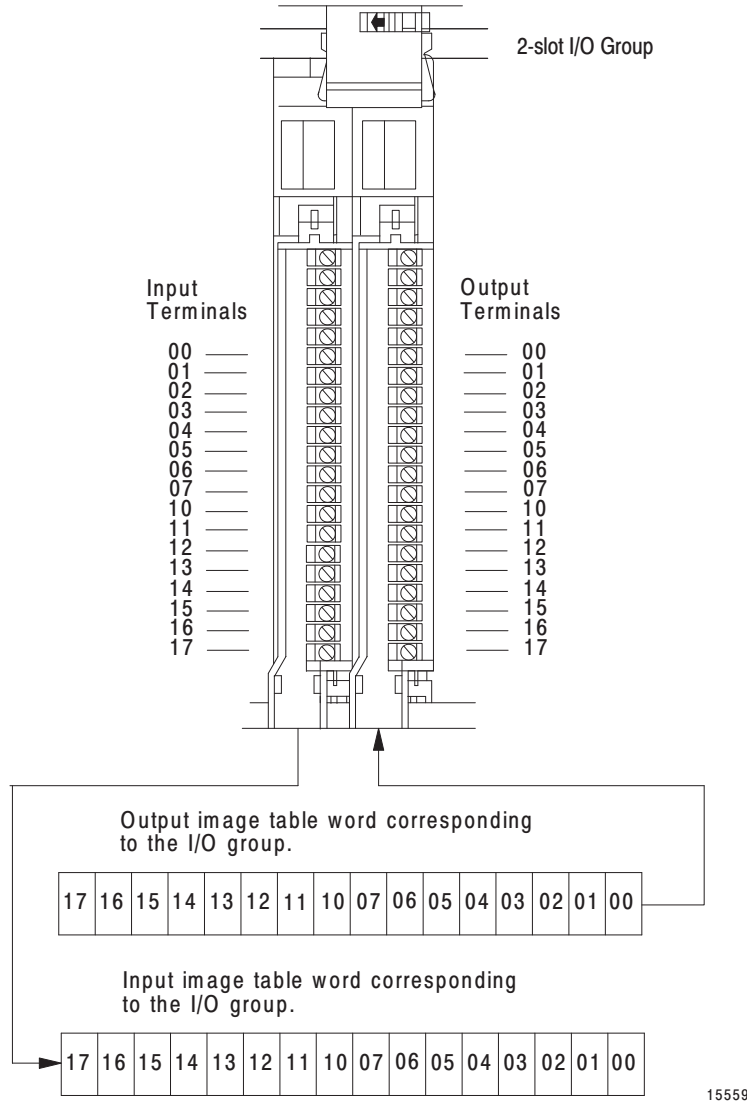

Because these modules use a full word in the image table, the only type of module you can use in a 2-slot I/O group with a 16-point module is one that performs the opposite (complementary) function; an input module complements an output module and vice-versa.

You can use an 8-point module with a 16-point module in a 2-slot group; it must perform the opposite function. However, eight bits in the I/O image table are unused.

### Identifying I/O Groups

You identify your I/O groups in one of three ways, depending on the addressing method and I/O chassis you use. Refer to:

- Figure 3.6 for 2-slot addressing when using series A I/O chassis.
- Figure 3.7 for 2-slot addressing when using series B I/O chassis.
- Figure 3.13 for 1-slot addressing when using series B I/O chassis.

**Figure 3.6**  
Identifying 2-slot I/O Groups with Series A I/O Chassis

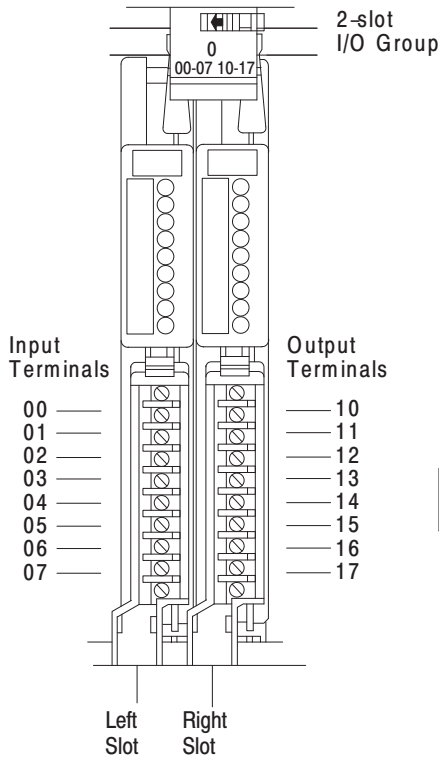

Example: Using I/O Group 0, a sample physical address (with its corresponding data table address) is:

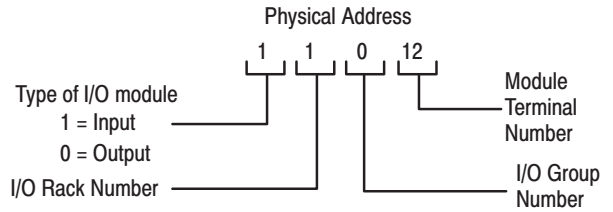

Input image table word corresponding to the I/O group.

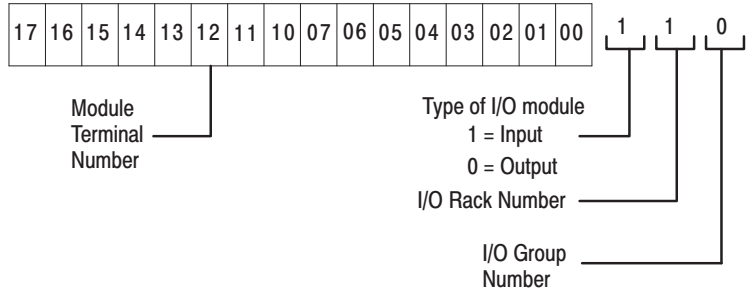

**Figure 3.7**  
Identifying 2-slot I/O Groups with Series B I/O Chassis

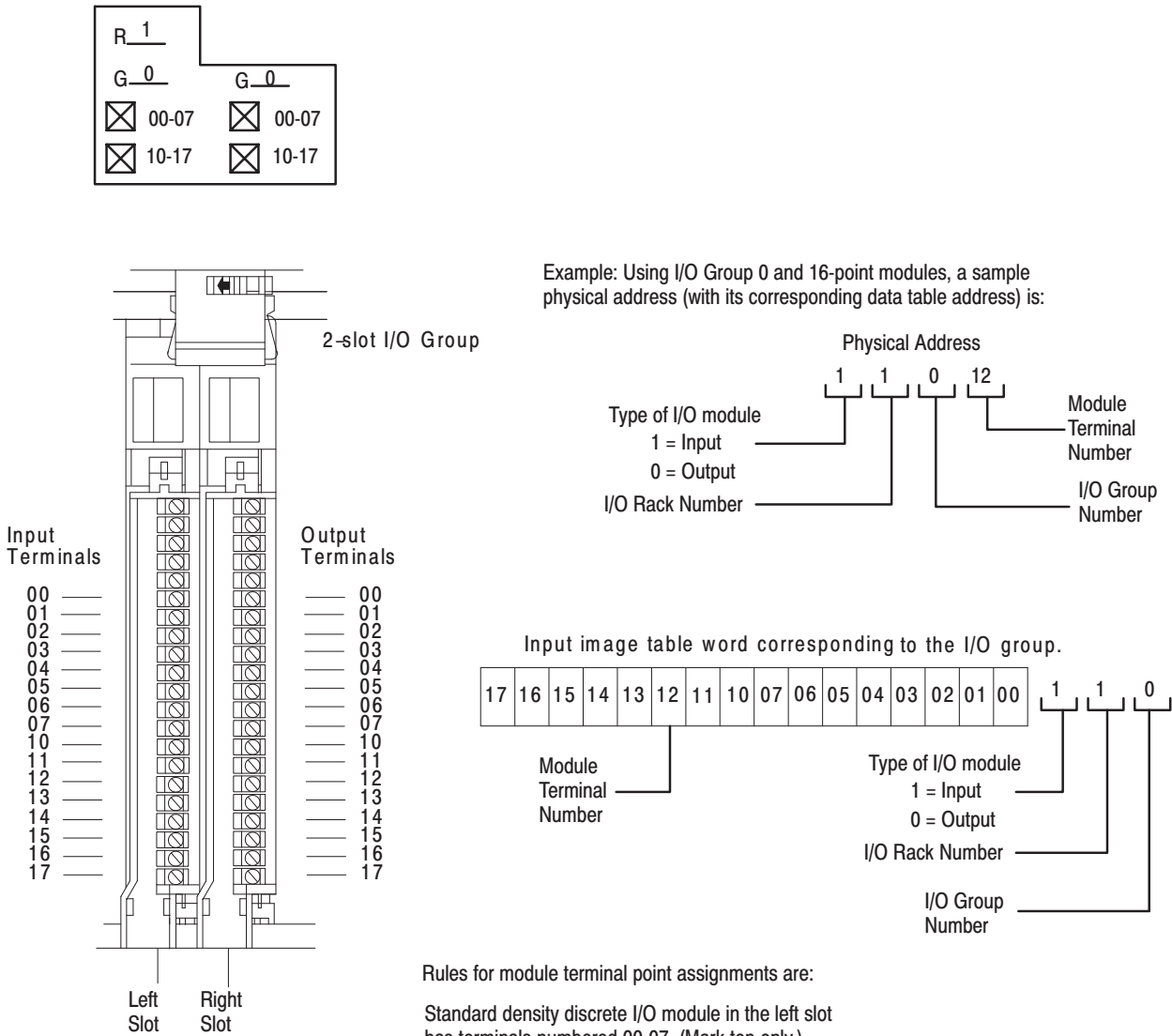

Rules for module terminal point assignments are:

Standard density discrete I/O module in the left slot has terminals numbered 00-07. (Mark top only.)

Standard density discrete I/O module in the right slot has terminals numbered 10-17. (Mark bottom only.)

High density (16-point) discrete I/O module in either slot has terminals numbered 00-07 and 10-17.

## Complementary I/O with 2-Slot Addressing

Some processors support a complementary I/O configuration. Refer to the user manual for your processor to see if it supports this type of configuration.

You configure complementary I/O by duplicating an I/O rack number of one I/O chassis (primary) in another I/O chassis (complementary), I/O group for I/O group. The I/O modules in the complementary chassis perform the opposite function of the corresponding modules in the primary chassis.

With 2-slot addressing you install, as a pair, the same type of 8-point I/O module in an I/O group of the primary chassis. You install, as a pair, the opposite type of 8-point I/O module in the corresponding I/O group of the complimentary chassis.

For example, with an I/O chassis set for 2-slot addressing, place two 8-point input modules in I/O group 0 of the primary chassis. In I/O group 0 of the complementary chassis, place two 8-point output modules (Figure 3.8). Use the same type of 8-point I/O modules in both slots of a single I/O group.

**Figure 3.8**  
**Example of Complementary I/O Configuration with 2-slot Addressing**

Primary 16-slot Chassis	I <sub>8</sub>	I <sub>8</sub>	O <sub>8</sub>	O <sub>8</sub>	I <sub>16</sub>	O <sub>16</sub>	O <sub>8</sub>	O <sub>8</sub>	BT	I <sub>8</sub> O <sub>8</sub> BT <sub>2</sub>	BT	O <sub>8</sub>	Double-slot BT	Double-slot BT		
I/O Group Number	0		1		2		3		4		5		6		7	
Complementary 16-slot Chassis	O <sub>8</sub>	O <sub>8</sub>	I <sub>8</sub>	I <sub>8</sub>	E M P T Y	E M P T Y	O <sub>8</sub> 1	O <sub>8</sub>	E M P T Y	O <sub>8</sub> 3	E M P T Y	E M P T Y	E M P T Y	O <sub>8</sub>	E M P T Y	O <sub>8</sub>

Example A

Primary 16-slot Chassis	I <sub>16</sub>	O <sub>16</sub>	I <sub>16</sub>	O <sub>16</sub>	I <sub>16</sub>	O <sub>16</sub>	I <sub>16</sub>	O <sub>16</sub>	I <sub>16</sub>	O <sub>16</sub>	I <sub>16</sub>	O <sub>16</sub>	I <sub>16</sub>	O <sub>16</sub>	I <sub>16</sub>	O <sub>16</sub>
I/O Group Number	0		1		2		3		4		5		6		7	
Complementary Chassis Not Allowed Except for Output	Outputs in the complementary chassis use the same bits in the output image table as the outputs in the primary chassis.															

Example B

I = Input Module  
 O = Output Module  
 BT = Block transfer Module

- 1 Output modules use the same output image table bits
- 2 Can be 8-point input or output module or single-slot block transfer module
- 3 Must be empty if corresponding primary slot is block transfer module

Follow these guidelines when configuring your remote system with complementary I/O chassis:

- Assign the complementary I/O rack number to a chassis of equal or smaller size than the primary chassis.
- If the complementary chassis is smaller than the primary one, set the last chassis switch on the complementary chassis to the ON position, unless the adapter is in the faulted I/O search mode.
- **For PLC-2 family processors:**
  - Connect the complementary chassis to the same scanner channel as the primary chassis.
  - Connect the complementary chassis to the remote trunkline as though they were additional primary chassis.
- **For PLC-3 processors,** connect the complementary chassis to a different scanner channel as the primary chassis.
- Assign the same beginning I/O group number to both I/O racks.
- You cannot configure complementary I/O in a chassis that uses a combination of 2-slot addressing and 16-point I/O.
  - You cannot use 32-point I/O modules in a complementary I/O configuration when you select 2-slot or 1-slot addressing.
  - You can place an output module opposite another output module; they reflect the same bits in the output image table.
- Do not place an input module opposite an input module.

You can use the following modules in either primary or complementary I/O chassis opposite any type of module:

Catalog Number	Description
1771-E1, -E2, -E3	Analog Input Expander Assembly
1771-E4	Analog Output Expander Assembly
1771-IY	Thermocouple Input Expander Module Assembly
1771-ES	Servo (Encoder Feedback) Expander Assembly
1771-KA2	Communication Adapter Module
1771-KE	Communication Controller Module
1771-KG	PLC-2 Family/RS-232-C Interface Module
1771-OJ	Pulse Output Expander Assembly
1771-AF	Fiber Optics Converter Module

### Module Placement with 2-slot Addressing

Figure 3.9 shows possible module placement when configuring complementary I/O with 2-slot addressing.

**Figure 3.9**  
Complementary I/O Configurations with 2-slot Addressing

Primary 16-slot Chassis	I <sub>8</sub>	I <sub>8</sub>	O <sub>8</sub>	O <sub>8</sub>	I <sub>16</sub>	O <sub>16</sub>	O <sub>8</sub>	O <sub>8</sub>	BT	I <sub>8</sub> O <sub>8</sub> BT <sub>2</sub>	BT	O <sub>8</sub>	Double-slot BT	Double-slot BT		
I/O Group Number	0		1		2		3		4		5		6		7	
Complementary 16-slot Chassis	O <sub>8</sub>	O <sub>8</sub>	I <sub>8</sub>	I <sub>8</sub>	E M P T Y	E M P T Y	O <sub>8</sub> 1	O <sub>8</sub>	E M P T Y	O <sub>8</sub> 3	E M P T Y	E M P T Y	E M P T Y	O <sub>8</sub>	E M P T Y	O <sub>8</sub>

Example A

Primary 16-slot Chassis	I <sub>16</sub>	O <sub>16</sub>	I <sub>16</sub>	O <sub>16</sub>	I <sub>16</sub>	O <sub>16</sub>	I <sub>16</sub>	O <sub>16</sub>	I <sub>16</sub>	O <sub>16</sub>	I <sub>16</sub>	O <sub>16</sub>	I <sub>16</sub>	O <sub>16</sub>	I <sub>16</sub>	O <sub>16</sub>
I/O Group Number	0		1		2		3		4		5		6		7	
Complementary Chassis Not Allowed Except for Output	Outputs in the complementary chassis use the same bits in the output image table as the outputs in the primary chassis.															

Example B

I = Input Module  
O = Output Module  
BT = Block transfer Module

- 1 Output modules use the same output image table bits
- 2 Can be 8-point input or output module or single-slot block transfer module
- 3 Must be empty if corresponding primary slot is block transfer module

13079

Follow these guidelines when you select 2-slot addressing:

- Place an 8-point output module opposite a 16-point input module.
- An I/O group having a 16-point input and output module cannot have a corresponding I/O group in the complementary chassis.
- You can place an output module opposite another output module; they reflect the same bits in the output image table.

You can use block-transfer modules in a complementary I/O system, with these restrictions:

- When using double-slot block-transfer modules:
  - The left slot of the complementary I/O group must be empty.
  - You can only place an 8-point output module (if any) in the right slot of the complementary I/O group.
- When using single-slot block-transfer modules:
  - The right slot of the primary I/O group can be another single-slot block-transfer module, or an 8-point input or output module.
  - The left slot of the complementary I/O group must be empty.
  - You can place an 8-point output module in the right slot of the complementary I/O group; this slot must be empty if the corresponding slot in the primary I/O group is a single-slot block-transfer module.

When you select 2-slot addressing, each pair of slots (one I/O group) is assigned to the corresponding pair of words in the input *and* output image tables. You assign one I/O rack number to eight I/O groups (Figure 3.10).

**Figure 3.10**  
I/O Image Table and Corresponding Hardware for One Assigned Rack Number with 2-slot Addressing

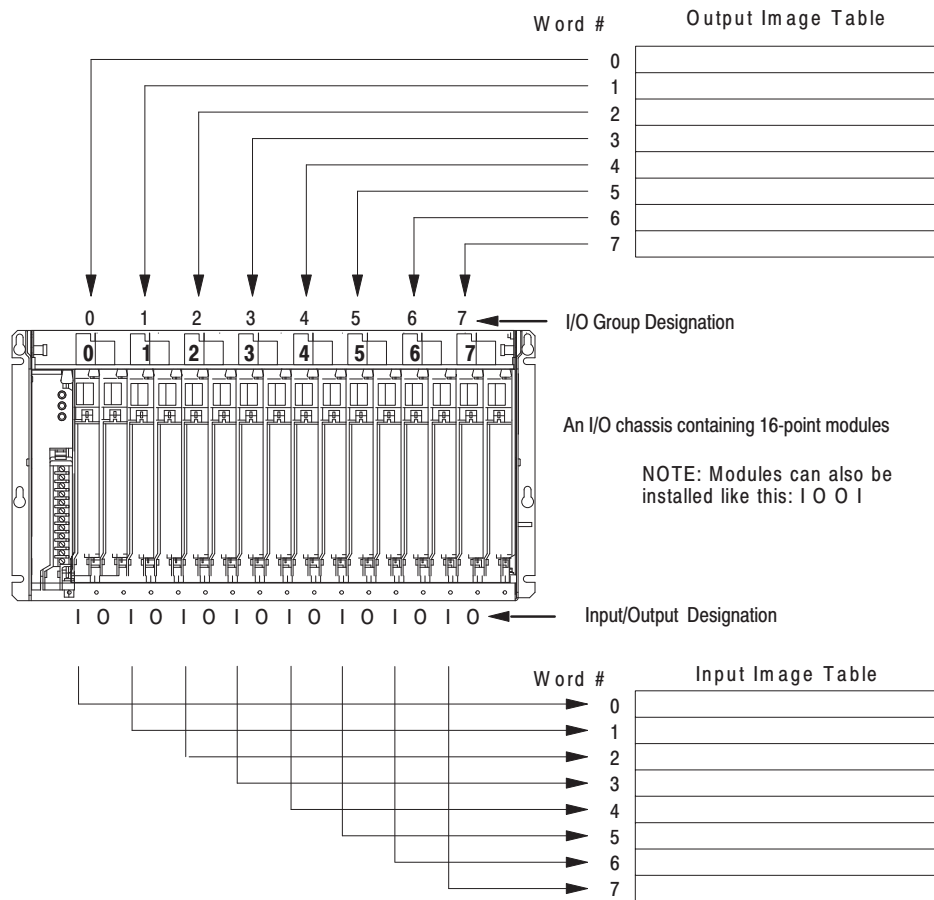

## 1-Slot Addressing

*Definition:* The processor addresses one I/O module slot as one I/O group.

*Concept:* The physical address of each I/O group corresponds to an input and output image table word. The type of module you install (8, 16, or 32-point) determines the number of bits in these words that are used.

You select 1-slot addressing by setting switches 5 and 6 of the I/O chassis backplane switch assembly:

- switch 5 to the ON position
- switch 6 to the OFF position

With 1-slot addressing, because 16 input AND 16 output bits are available in the processor's image table for each I/O slot, you can use any mix of 8 or 16-point I/O modules in the I/O chassis.

To use 32-point I/O modules with 1-slot addressing, you must install, as a pair, an input module and an output module in 2 adjacent slots of the I/O chassis beginning with I/O slot 0 (Figure 3.11). If you cannot pair the modules in this way, one of the two slots of the pair must be empty. For example, if I/O slot 0 holds a 32-point input module, I/O slot 1 can hold an 8, 16, or 32-point output module (or a module that uses the backplane for power only); otherwise, it must be empty.

**Figure 3.11**  
Using 32-point I/O Modules with 1-slot Addressing

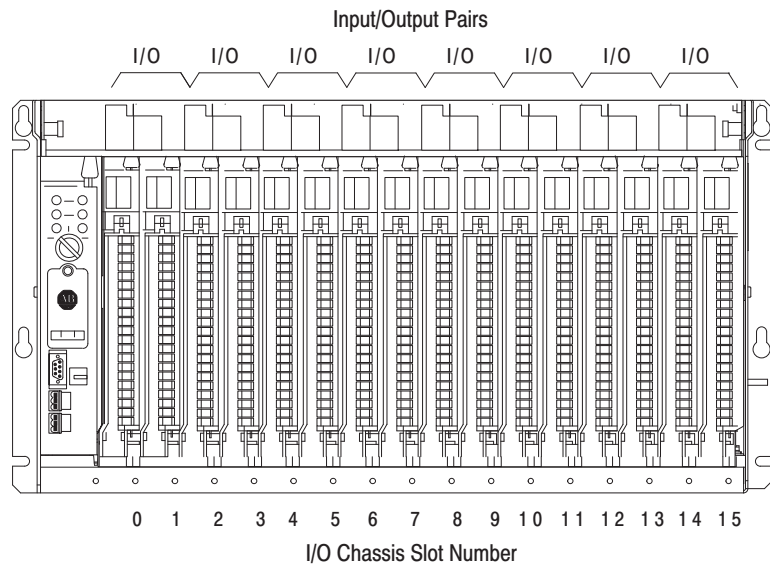

14973

Thirty-two-point I/O modules need 32 input or 32 output bits in the processor's image table. Because only 16 input and 16 output bits are available for each I/O group, to address a 32-point I/O module, the remote I/O adapter module uses the unused input or output word associated with the adjacent I/O slot.

Refer to Figure 3.12. When the 1771-ASB remote adapter module addresses a 1-slot I/O group containing a 32-point I/O module, the adapter module uses the unused word assigned to the adjacent I/O module slot. For example, the adapter module uses the unused input word associated with I/O slot 1 (because that slot must hold an output module and does not use its input word).

Figure 3.13 illustrates the concept of 1-slot addressing with two 32-point I/O modules.

**Figure 3.12**  
1-slot I/O Group Concept With 32-point I/O Modules

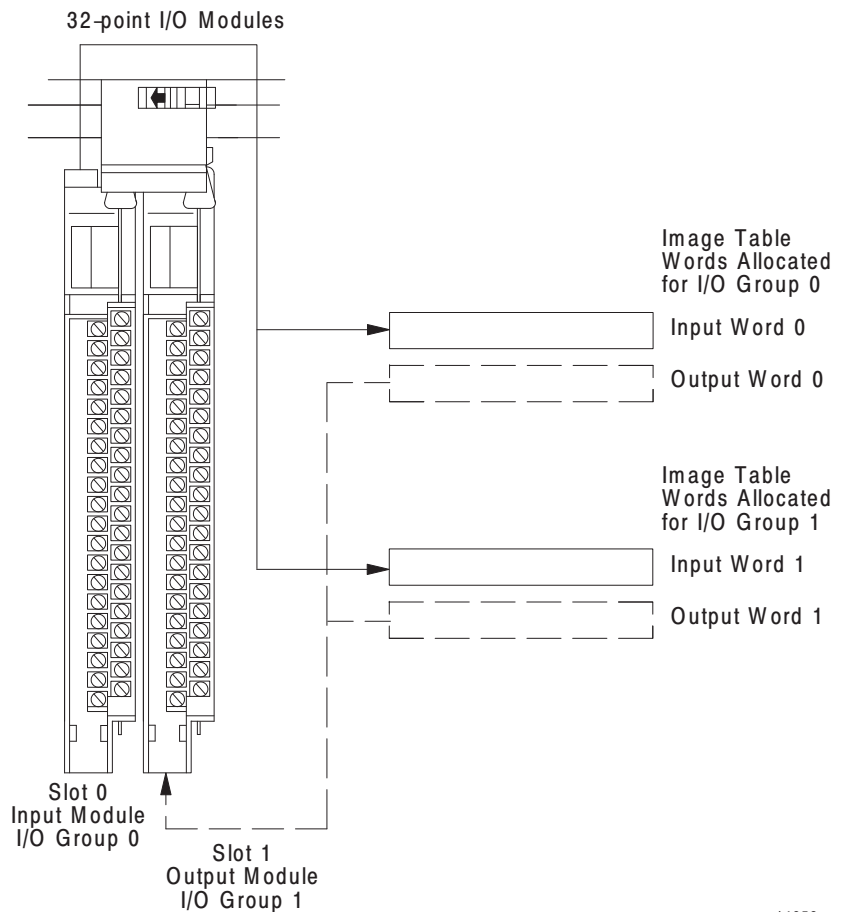

14258

### Identifying I/O Groups

You identify your I/O groups in one of three ways, depending on the addressing method and I/O chassis you use. Refer to Figure 3.13 for 1-slot addressing when using series B I/O chassis.

**Figure 3.13**  
Identifying 1-slot I/O Groups with Series B I/O Chassis

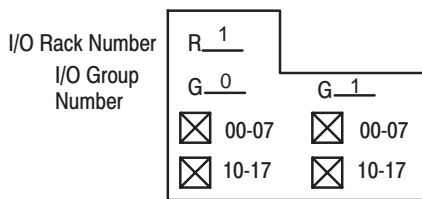

Example: Using I/O Group 0 and 16-point modules, a sample physical address (with its corresponding data table address) is:

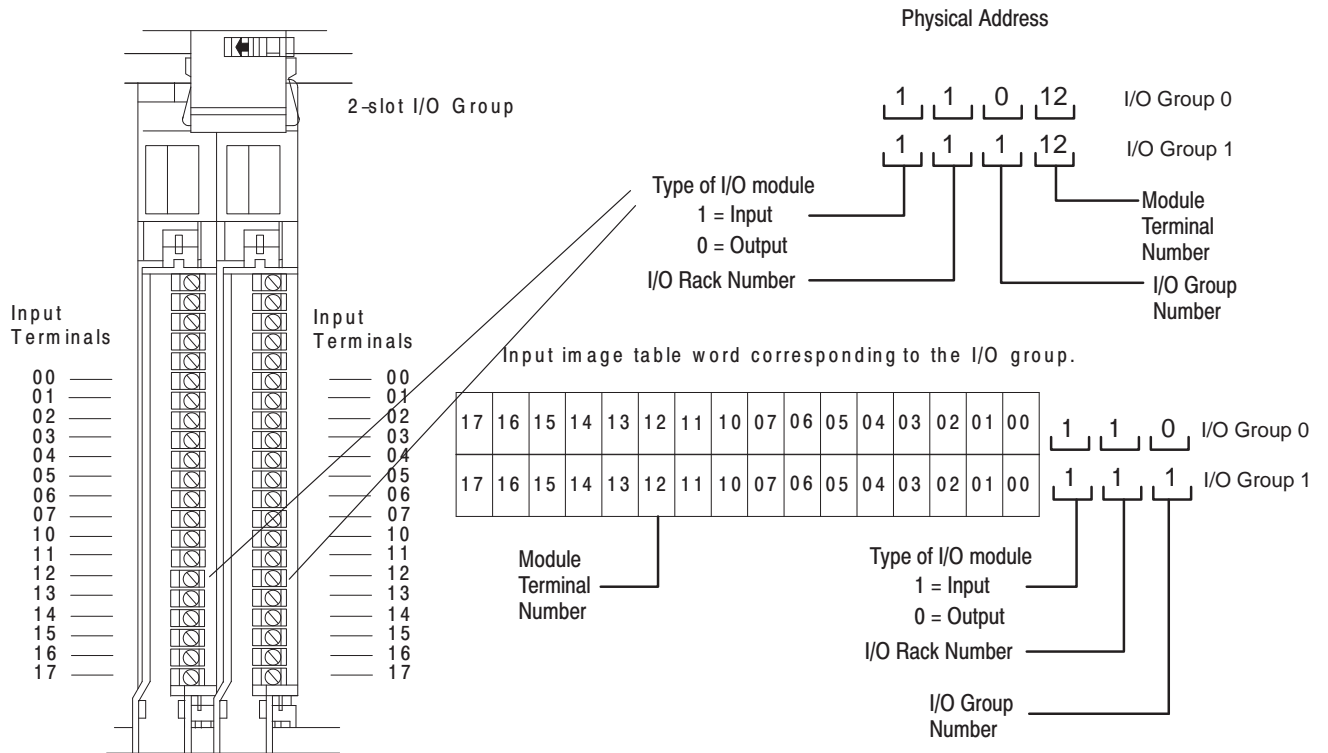

Rules for module terminal point assignments are:

Standard density discrete I/O module in the left slot has terminals numbered 00-07. (Mark top only.)

High density (16-point) discrete I/O module in either slot has terminals numbered 00-07 and 10-17.

10810-1

### Module Placement with 1-slot Addressing

Figure 3.14 shows possible module placement for complementary I/O with 1-slot addressing.

**Figure 3.14**  
Complementary I/O Configurations with 1-slot Addressing

Primary 16-slot Chassis	I	I	O	O	I	O	O	BT	Double-slot BT	O	I	I	I	O	O	
I/O Group Number	0	1	2	3	4	5	6	7	0	1	2	3	4	5	6	7
Complementary 16-slot Chassis	O	O	I	I	O	I	O	EMPTY <sup>3</sup>	EMPTY <sup>3</sup>	I, O, BT <sup>2</sup>	I	O	O	O	I	I

Example A

Primary 16-slot Chassis	I	I	I	I	I	I	I	I	I	I	I	I	I	I	I	I
I/O Group Number	0	1	2	3	4	5	6	7	0	1	2	3	4	5	6	7
Complementary 16-slot Chassis	O	O	O	O	O	O	O	O	O	O	O	O	O	O	O	O

Example B

I = Input Module (8- or 16-point)  
O = Output Module (8- or 16-point)  
BT = Block transfer Module

1 Output modules use the same output image table bits  
2 Can be input or output module (8- or 16-point) single-slot block transfer module  
3 Must be empty if corresponding primary slot is block transfer module

13080

Follow these guidelines when you select 1-slot addressing:

- Place input modules opposite output modules; place output modules opposite input modules.
- You can use 8-point or 16-point I/O modules.
- Output modules placed opposite output modules reflect the same bits in the output image table.

You can use block-transfer modules in a complementary I/O configuration with 1-slot addressing. Remember that when you select 1-slot addressing, an I/O group is one module slot. Use block-transfer modules with these restrictions:

- When using double-slot block-transfer modules:
  - The left slot of the two corresponding I/O groups must be empty.
  - You can place any single-slot I/O module in the right slot of the two corresponding I/O groups.

When using single-slot block-transfer modules, the corresponding I/O group must be empty.

## Assigning I/O Rack Numbers with 1-Slot Addressing

The following rules apply when you assign I/O rack numbers:

When you select 1-slot addressing, set switches of switch assembly S1 to assign the first I/O rack number of the chassis. The remote I/O adapter module automatically assigns the next higher I/O rack number to the remaining I/O groups of the chassis.

For example, if you want a 16-slot chassis that you set for 1-slot addressing to begin with I/O rack number 0, set switches of switch assembly S1 for I/O rack number 0. The adapter module automatically assigns I/O rack number 1 to the remaining I/O groups of the chassis (Figure 3.15).

**Figure 3.15**  
Assigning I/O Rack Numbers with 1-slot Addressing

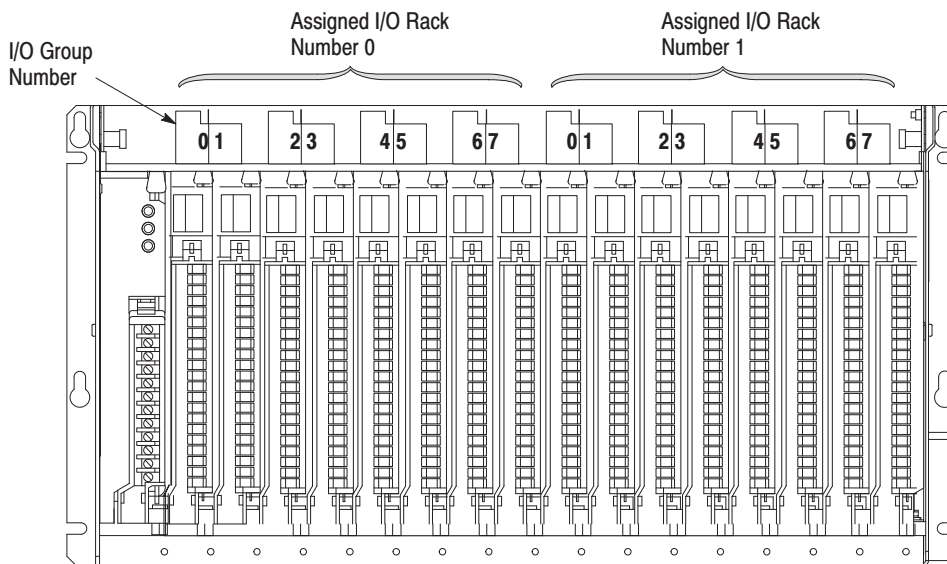

1771-A4B I/O Chassis using 1-slot addressing

13077

Set switches of switch assembly S1 on the remote I/O adapter module for I/O rack number 0. The adapter automatically assigns I/O rack number 1 to the remaining I/O group of the chassis.

You assign one I/O rack number to eight I/O groups, regardless of which addressing method you select.

When you select 1-slot addressing, each individual slot (one I/O group) is assigned to the corresponding word in the input *or* output image tables. You assign one I/O rack number to eight I/O groups (Figure 3.16).

**Figure 3.16**  
**I/O Image Table and Corresponding Hardware for One Assigned Rack Number with 1-slot Addressing**

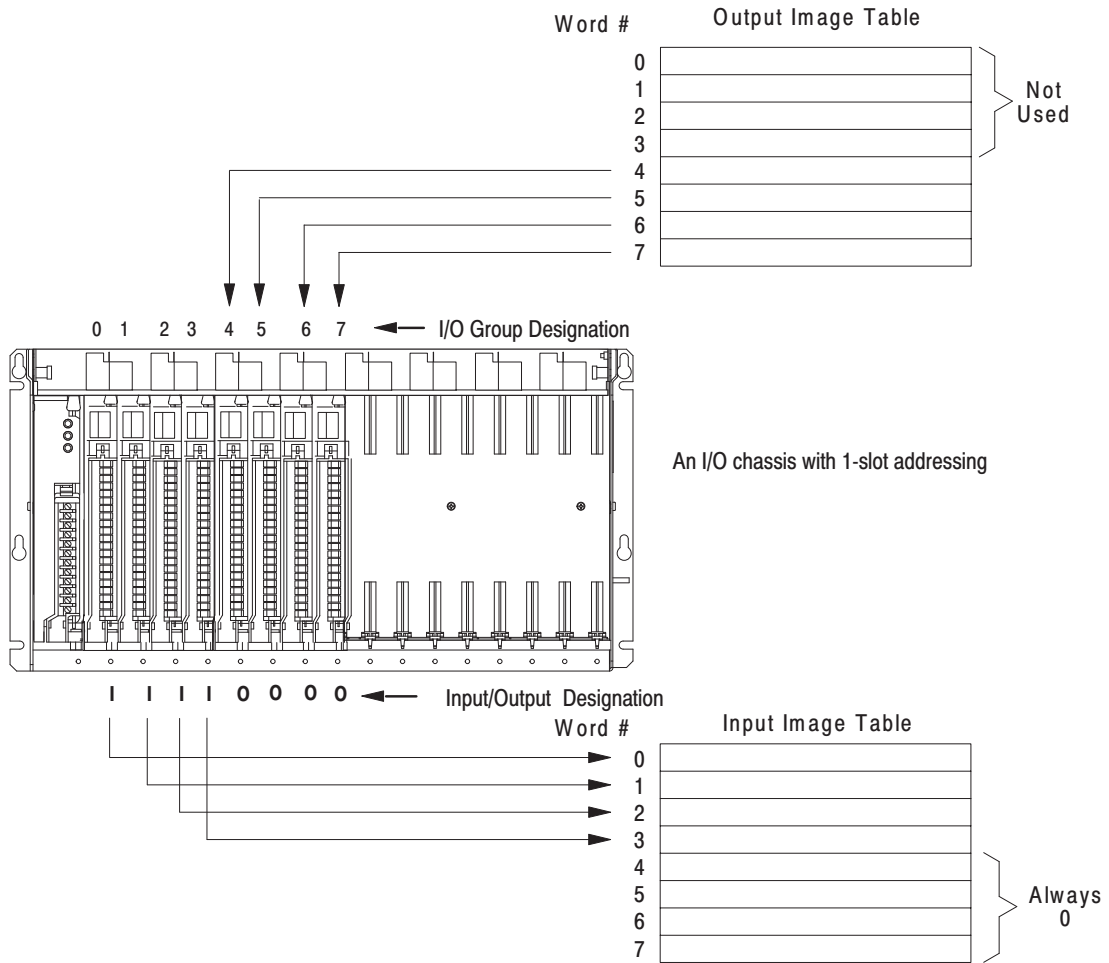

14967

## 1/2- Slot Addressing

*Definition:* The processor addresses one-half of an I/O module slot as one I/O group.

*Concept:* The physical address of each I/O slot corresponds to two input and two output image table words. The type of module you install (8-, 16-, or 32-point) determines the number of bits in these words that are used.

You select 1/2-slot addressing by setting switches 5 and 6 of the I/O chassis backplane switch assembly:

- switch 5 to the OFF position
- switch 6 to the ON position

With 1/2-slot addressing, since 32 inputs bits AND 32 output bits are available in the processor's image table for each I/O group, you can mix 8-, 16- and 32-point I/O modules in any order in the I/O chassis.

Figure 3.17 illustrates the 1/2-slot addressing concept with a 32-point I/O module. A 32-point I/O module (with 1/2-slot I/O groups) uses two words of the image table. When you use 8- and 16-point I/O modules with 1/2-slot addressing, you get fewer total I/O points.

**Figure 3.17**  
1/2-slot Addressing Concept

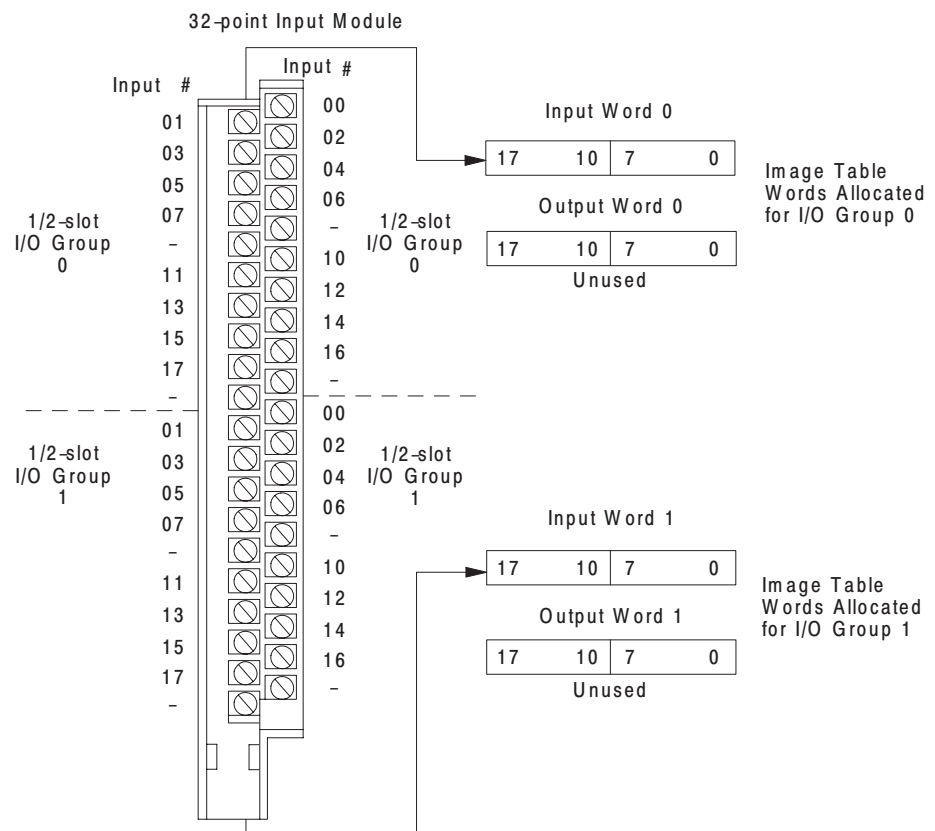

14259

### Assigning I/O Rack Numbers with 1/2-slot Addressing

The following rules apply when you assign I/O rack numbers for 1/2-slot addressing:

- One assigned I/O rack number is made up of eight I/O groups (Figure 3.18).
- The maximum number of I/O racks you can assign to the different chassis sizes are:
  - one I/O rack to 1771-A1B chassis
  - two I/O racks to 1771-A2B chassis
  - three I/O racks to 1771-A3B chassis
  - four I/O racks to 1771-A4B chassis
- You can mix addressing methods in your remote system on a chassis-by-chassis basis (1-slot and 1/2-slot addressing with 32-point I/O modules).
- You cannot assign one I/O rack number to more than one I/O chassis when you select 1/2-slot addressing.
- Each I/O chassis begins an assigned I/O rack number. Make sure that you set switches 7 and 8 of switch assembly SW1 to the ON position when you select 1/2-slot addressing. The remote I/O adapter module automatically assigns the next higher I/O rack number(s) to the remaining I/O groups of the chassis.

**Figure 3.18**  
**I/O Image Table and Corresponding Hardware for One**  
**Assigned Rack Number with 1/2-slot Addressing**

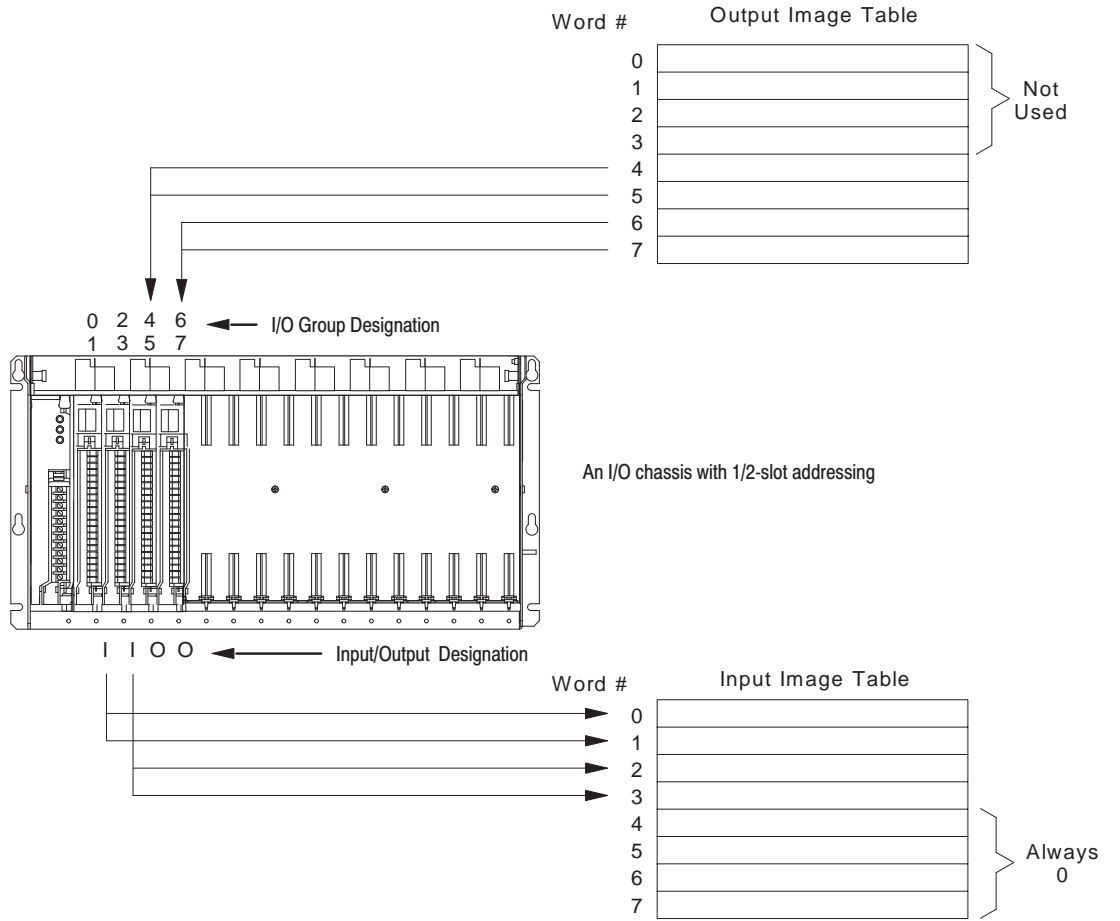

14974

### Complementary I/O with 1/2-Slot Addressing

Some processors support a complementary I/O configuration. Refer to the user's manual for your processor to see if it supports this type of configuration.

You configure complementary I/O by duplicating an I/O rack number of one I/O chassis (primary) in another I/O chassis (complementary), I/O group for I/O group. The I/O modules in the complementary chassis perform the opposite function of the corresponding modules in the primary chassis.

#### Module Placement with 1/2-slot Addressing

Figure 3.19 shows possible module placement for a complementary I/O configuration with 1/2-slot addressing.

**Figure 3.19**  
Complementary I/O Configuration with 1/2-slot Addressing

Primary 12-slot Chassis	I	I	O	O	I	O	O	BT	Double-slot BT	O	I	
I/O Group Number	01	23	45	67	01	23	45	67	01	23	45	67
Complementary 12-slot Chassis	O	O	I	I	O	I	O	EMPT Y 3	EMPT Y 3	I, O, BT	I	O

Example A

Primary 12-slot Chassis	I	I	I	I	I	I	I	I	I	I	I	I
I/O Group Number	01	23	45	67	01	23	45	67	01	23	45	67
Complementary 12-slot Chassis	O	O	O	O	O	O	O	O	O	O	O	O

Example B

I = Input Module  
O = Output Module  
BT = Block transfer Module

- 1 Output modules use the same output image table bits
- 2 Can be input or output module (8- or 16-point) single-slot block transfer module
- 3 Must be empty if corresponding primary slot is block transfer module

Follow these guidelines when you select 1/2-slot addressing:

- Place input modules opposite output modules; place output modules opposite input modules.
- You can use 8, 16 and 32-point I/O modules.
- Output modules placed opposite output modules reflect the same bits in the output image table.

You can use block-transfer modules in a complementary I/O configuration with 1/2-slot addressing. Use block-transfer modules with these guidelines:

- When using double-slot block-transfer modules in the primary chassis:
  - The left-most slot of the two corresponding I/O slots in the complementary chassis must be empty.
  - You can place any single-slot I/O module in the right slot of the two corresponding I/O slots of the complementary chassis
- When using single-slot block-transfer modules, the corresponding I/O slot in the complementary chassis must be left empty.

### Mixing 1 and 2-Slot Addressing in Individual Chassis

You can have a mix of 1-slot and 2-slot addressing in individual chassis assigned one I/O rack number (with up to eight I/O groups). For example: you can select 2-slot addressing for a 1771-A2B I/O chassis and 1-slot addressing for a 1771-A1B chassis to make up one assigned I/O rack number (Figure 3.20).

**Figure 3.20**  
Mixing Addressing Methods in Chassis Assigned One I/O Rack Number

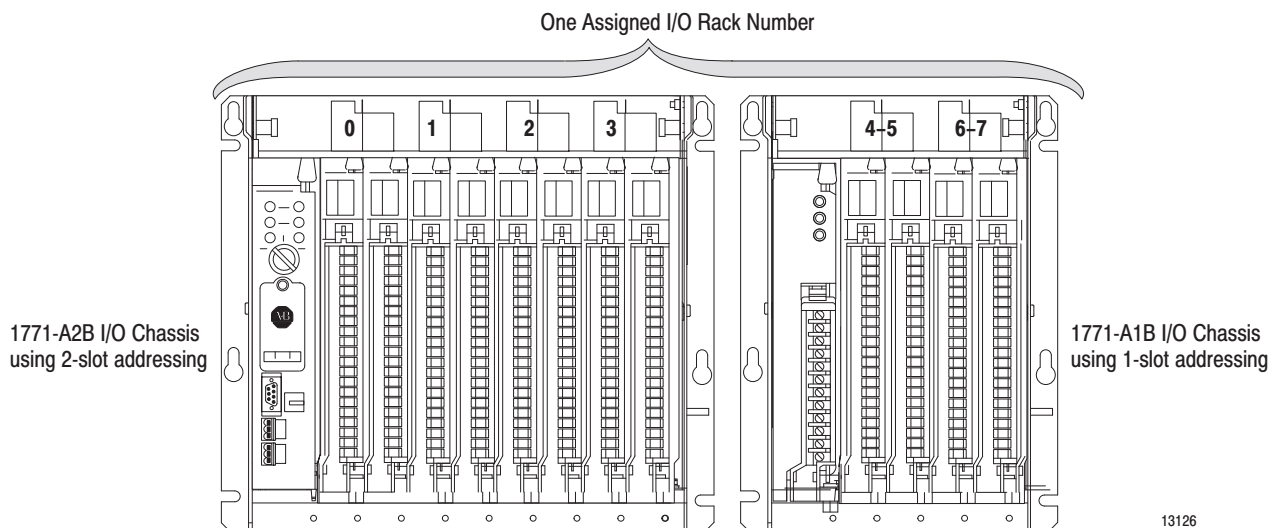

13126

## Acceptable Chassis Combinations

Not all chassis combinations are acceptable in making I/O rack number assignments. For example, a 1771-A4B I/O chassis cannot complete an assigned I/O rack number that starts in a 1771-A1 I/O chassis. Refer to Figure 3.B for acceptable beginning I/O group numbers when making your I/O rack number assignments.

**Table 3.B**  
Acceptable Beginning I/O Group Numbers

If you select:	and:	The beginning I/O group number can be:
2-slot addressing	4-slot chassis	0, 2, 4, 6
	8-slot chassis	0, 2, 4
	12-slot chassis	0, 2
	16-slot chassis	0
1-slot addressing	4-slot chassis	0, 2, 4, 6
	8-slot chassis	0, 2, 4, 6
	12-slot chassis	0, 2, 4,
	16-slot chassis	0
1/2-slot addressing	4-slot chassis	0
	8-slot chassis	0
	12-slot chassis	0
	16-slot chassis	0

## I/O Chassis/Adapter Module Combinations

Table 3.C shows the addressing methods you can achieve with the Series B chassis and the various remote I/O adapter modules.

**Table 3.C**  
**Series B Chassis/Adapter Module Combinations**

Remote I/O Adapter Module Catalog Number	I/O Points Per Module	Addressing Mode		
		2-Slot	1-Slot	1/2-Slot
1771-AS	8	Yes	No	No
	16	*	No	No
	32	No	No	No
1771-ASB Series A	8	Yes	Yes	No
	16	*	Yes	No
	32	No	No	No
1771-ASB Series B, C, D and E	8	Yes	Yes	Yes
	16	*	Yes	Yes
	32	No	*	Yes

\* Conditional module placement: you must use an input module and an output module in two adjacent slots of the I/O chassis beginning with slot 0.

**IMPORTANT:** Series A I/O chassis let you use 2-slot addressing with 8-point I/O modules only, regardless of the type of adapter module you use. This chart is valid for series B I/O chassis. You need series B I/O chassis to achieve 1-slot and 1/2-slot addressing with 16-point and 32-point I/O modules.

## Summary

In this chapter we discussed how to address your hardware and the various remote I/O configurations and options you can use in your remote system.



# Troubleshooting

## Chapter Objectives

In this chapter, you will learn how to use the indicators on the module frontplate for troubleshooting the module.

## Troubleshooting With the Indicator Lights

The module has three indicators on the front plate, as shown below. Use these indicators for troubleshooting the module.

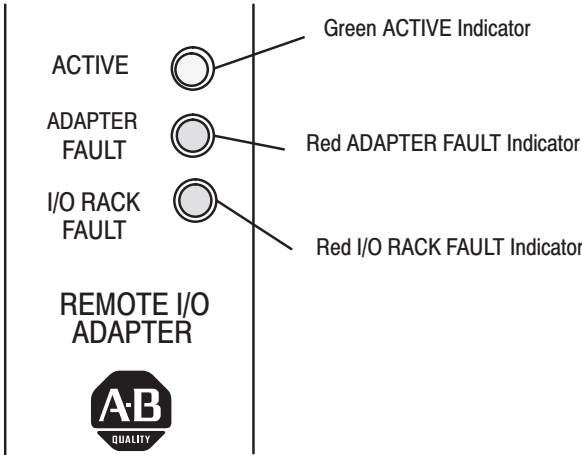

10811-1

The following table describes problems that may occur, probable causes, and recommended courses of action.

**Table 4.A**  
**Remote I/O System Troubleshooting Guide**

Indicators			Description	Probable Cause	Recommended Action
Active	Adapter Fault	I/O Rack			
On	Off	Off	Normal indication; remote adapter is fully operational; processor is in Run mode		
Off	On	Off	Adapter crash.	RAM memory fault. Watchdog timeout	Cycle power. Replace module if problem reoccurs.
On	Blink	Off	Module placement error	I/O module in incorrect slot.	Place module in correct slot in chassis.
Blink in unison		Off	Incorrect starting I/O group number	Error in starting I/O group number or I/O rack address	Check dipswitch settings. Refer to table 3.B to verify acceptable beginning I/O group number; set switches correctly
On	On	On	Module not communicating	Incorrect baud rate setting	Check dipswitch setting
Off	On	On	Module not communicating	Scan switch set for "all but last 4 slots" in 1/4 rack	Reset scan switch setting
Blink	Off	Off	Remote adapter not actively controlling I/O (scanner to adapter communication link is normal) <sup>4</sup> ; scanner manual or autoconfiguration <sup>8</sup> was successful	Processor is in program or test mode Scanner is holding adapter module in fault mode; Configuration mismatch	Place processor in Run mode. Fault should be cleared by I/O scanner Correct the configuration mismatch, i.e. incorrect rack size, rack number
LEDs sequence on/off from top to bottom			Module not communicating	Another remote I/O adapter with the same address is on the link.	Correct the address.
Blink alternately		Off	Adapter module not actively controlling I/O <sup>2</sup>  Adapter module in processor restart lockout mode (adapter to scanner link is normal) <sup>5</sup>	Processor restart lockout switch on chassis backplane switch assembly on <sup>1</sup>	Depress reset button to clear lockout feature or cycle power; if after repeated attempts indicators are still blinking, check: <ul style="list-style-type: none"> <li>• pushbutton not wired properly to field wiring arm</li> <li>• wiring arm not connected to adapter module</li> <li>• adapter module was reset by processor/scanner, then immediately faulted</li> </ul>
Off	Off	On	I/O chassis fault. <sup>2</sup> No communication on link.	Problem exists between: <ul style="list-style-type: none"> <li>• adapter and module in chassis; the module will stay in fault mode until fault is corrected</li> <li>• shorted printed circuit board runs on backplane or I/O module</li> </ul>	Cycle power to the chassis to clear a problem resulting from high noise <sup>3</sup> <ul style="list-style-type: none"> <li>• remove and replace all I/O modules one at a time</li> <li>• if problem does not clear, something is wrong in chassis or I/O module</li> </ul>
Blink	Off	On	Communication on link. Chassis violation.	Possible shorted backplane in chassis. Excessive noise on backplane. <sup>6</sup>	Identify source of noise. Suppress output module inductive loads or noise sources in proximity to output module wiring. Target the problem by splitting the rack into smaller racks. Check chassis, Replace chassis as necessary.

Indicators			Description	Probable Cause	Recommended Action
Active	Adapter Fault	I/O Rack			
Blink	On	Off	Module identification line fault	Excessive noise on backplane	Identify source of noise. Check power supply incoming ac power with a line disturbance analyzer. Monitor scanner channel for retries to determine if noise is entering the RIO cable. Possible problem with block transfer module. Remove to isolate.
Off	Off	Off	Module not communicating <sup>7</sup>	Autoconfiguration <sup>8</sup> unsuccessful Scanner not configured properly  Power supply fault  Wiring from scanner to adapter module disrupted  One faulted chassis within a rack group address causing scanner/distribution panel to fault all chassis in rack group address (when in disable search mode)	Check scanner COM indicator; Steady green – normal; Blinking green – at least one node on the link is faulted or failed; Red – scanner may have a hardware problem, replace. Blinking red – all adapters on link have faulted or duplicate node address detected Off – scanner channel has not been configured to be active on the RIO link (not online)  Refer to Autoconfigure below.  Check power supply, cable connections, and make sure adapter module is fully seated in chassis.  Correct cable and wiring defects  Check sequentially from the first module to the last module to pinpoint fault; correct any faults and proceed to the next chassis

1. You must select the operating mode of the remote I/O adapter module as outlined in the publication furnished with the remote I/O scanner/distribution panel, remote I/O scanner-program interface module, or I/O scanner-message handling module. Pay close attention to the disable search mode in the 1771-SD, -SD2.
2. The I/O chassis is in faulted mode as selected by the last state switch on the chassis backplane.
3. Cycling power clears the block-transfer request queue. All pending block transfers are lost. Your program must repeat the request for block transfers from the chassis.
4. If a fault occurs and the processor is in the run mode but is actually operating in the dependent mode, the chassis fault response mode is selected by the last state switch on the chassis backplane.
5. The I/O chassis is in faulted mode as selected by the last state switch on the chassis backplane.
6. If excessive chassis faults occur, check switch SW-2, position 6 for the OFF position.
7. The adapter considers loss of communication if it sees no transmissions on the RIO network for 100ms or sees 255 transmissions on the RIO with none to the adapter.
8. Autoconfigure is a feature of the PLC-5 processor family.

### **Autoconfigure**

For a successful autoconfigure, insure that a processor I/O status file exists, all rack and reset and inhibit bits are zeroed, and the channel is set up for scanner, and the baud rate is correct.

Make sure that:

- the input and output image tables are large enough to accommodate the rack address you are attempting to assign
- the adapter and chassis switches are set correctly, especially communication rate, rack and group.
- the wiring is correct and properly terminated
- the remote I/O racks are not split across scanner channels or the local chassis

If autoconfigure is still not successful, save the program, clear processor memory by disconnecting the battery, create an I/O status file, reconfigure the scanner channel, and try again.

#### **1747-SN Scanner**

For the adapter to be recognized by the 1747-SN scanner module, the G-files must be properly constructed for rack and starting group and scanner switches must be set for the correct communication rate.

#### **1756-DHRIO Scanner**

For the adapter to be recognized by the scanner module, the adapter must be added for each logical rack under the scanner module and be properly configured in the Logix5550 Controller Organizer configuration tree, and the scanner switches must be set correctly for remote I/O and node number.

## **Summary**

In this chapter you learned how to use the indicators on the front of the module to troubleshoot your module.

## Specifications

Module Location	1771 I/O chassis, leftmost slot
Chassis Distance	2500 ft @ 230.4K Baud 5000 ft @ 115.2K Baud 10000 ft @ 57.6K Baud
Interconnect Cable	1770-CD□
Power Dissipation	5 Watts
Thermal Dissipation	17.06 BTU/hr
Backplane Current	1.0A @ 5V
Keying	Upper connector: between 54 and 56 Lower connector: between 16 and 18
Environmental Conditions	
Operational Temperature	0° to 60°C (32° to 140°F)
Storage Temperature	-40° to 85°C (-40° to 185°F)
Relative Humidity	5% to 95% (without condensation)
Field Wiring Arm	Cat. No. 1771-WB
Field Wiring Arm Screw Torque	7-9 pound-inches
Conductor Size	
Remote I/O blue cable	20 AWG (0.5mm <sup>2</sup> ) stranded copper with 1 wire per terminal <sup>1</sup>
User supplied I/O rack restart switch Category	20 AWG (0.5mm <sup>2</sup> ) with 3/64 (1.2mm) insulation maximum <sup>2</sup>
Termination Resistor	82Ω - A-B part number 740018-23 150Ω - A-B cat. no. 1770-XT
Agency Certification (when product is marked)	<ul style="list-style-type: none"> <li>• CSA Certified</li> <li>• CSA Class I, Division 2 Groups A, B, C, D certified</li> <li>• UL listed</li> <li>• CE marked for all applicable directives</li> <li>• C-Tick marked for all applicable acts.</li> </ul>

1. Connect only 1 stranded wire to a terminal. Use stranded copper wire only.  
2. Use this conductor category information for planning conductor routing. Refer to publication 1770-4.1, "Industrial Automation Wiring and Grounding Guidelines for Noise Immunity."



## Settings for 1771-AS and 1771-ASB Series A, B, C and D Remote I/O Adapters

### General Information

This appendix provides information on previous remote I/O adapters supplied by Allen-Bradley. The following table lists the adapter and respective figure reference.

Figure	Description	Applies to:
B.1	Keying Diagram for 1771-ASB series A, B and C	1771-ASB series A, B and C
B.2	Keying Diagram for 1771-AS	1771-AS
B.3	Field Wiring Arm Connection for 1771-AS, -ASB series A, B and C	1771-AS 1771-ASB series A, B and C
B.4	Module Switch Assembly Settings for 1771-AS, -ASB series A and B Adapter for PLC-2 Family Processors	1771-AS 1771-ASB series A, B
B.5	Module Switch Assembly Settings for 1771-ASB series C Adapter for PLC-2 Family Processors	1771-ASB series C and D
B.6	Module Switch Assembly Settings for 1771-AS and 1771-ASB series A and B Adapters for PLC-3 Family Processors	1771-AS 1771-ASB series A, B
B.7	Module Switch Assembly Settings for 1771-ASB series C Adapters for PLC-3 Family Processors	1771-ASB series C and D
B.8	Module Switch Assembly Settings for 1771-AS and 1771-ASB series A and B Adapters for PLC-5 Family, SLC and ControlLogix Processor Systems Processors without Complementary I/O	1771-AS 1771-ASB series A, B
B.9	Module Switch Assembly Settings for 1771-ASB series C Adapters for PLC-5 Family, SLC and ControlLogix Processor Systems Processors without Complementary I/O	1771-ASB series C and D
B.10	Module Switch Assembly Settings for 1771-AS, -ASB series A and B Adapters for PLC-5 Family, SLC and ControlLogix Processor Systems Processors with Complementary I/O	1771-AS 1771-ASB series A, B
B.11	Module Switch Assembly Settings for 1771-ASB series C Adapters for PLC-5 Family, SLC and ControlLogix Processor Systems Processors with Complementary I/O	1771-ASB series C and D
B.12	I/O Chassis Backplane Switch Assembly Settings for 1771-AS Remote Adapter Module in PLC-2, SLC and ControlLogix Processor Systems Family Processor System	1771-AS
B.13	I/O Chassis Backplane Switch Assembly Settings for 1771-AS Remote Adapter Module in PLC-3 Family, SLC and ControlLogix Processor Systems Processor System	1771-AS
B.14	I/O Chassis Backplane Switch Assembly Settings for Remote Adapter Module in PLC-2, SLC and ControlLogix Processor Systems Family Processor System	1771-ASB series C and D
B.15	I/O Chassis Backplane Switch Assembly Settings for Remote Adapter Module in PLC-3 Family Processor System	1771-ASB series C and D

Figure	Description	Applies to:
B.16	I/O Chassis Backplane Switch Assembly Settings for Remote Adapter Module in PLC-5 Family Processor System	1771-ASB series C and D
B.17	I/O Chassis Backplane Switch Assembly Settings for Remote Adapter Module in PLC-5 Family, SLC and ControlLogix Processor Systems in Remote Configuration	1771-ASB series C and D
B.18	I/O Chassis Backplane Switch Assembly Settings for Remote Adapter Module in PLC-5/250 Processor System	1771-ASB series C and D

**Figure B.1**  
Keying Diagram for 1771-ASB series A, B, C and D

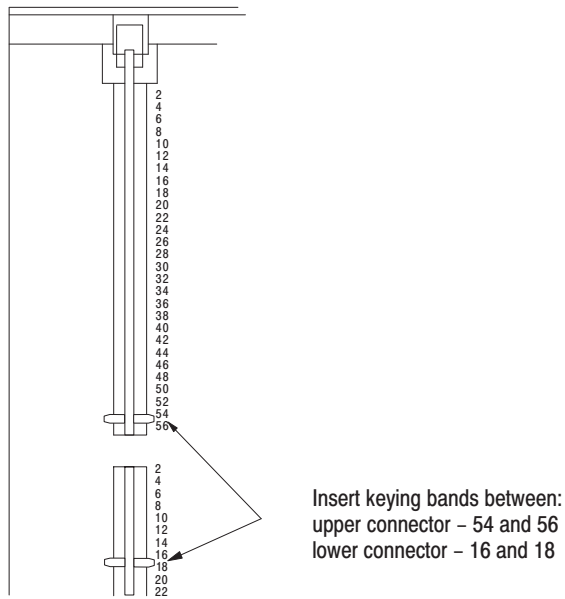

12252

**Figure B.2**  
Keying Diagram for 1771-AS Remote I/O Adapter

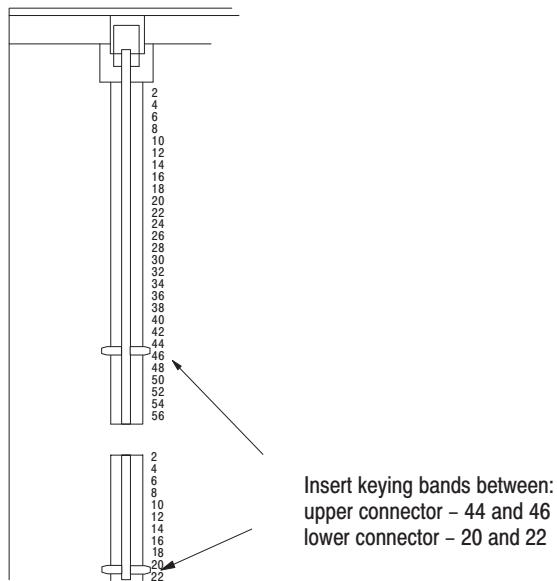

12252

**Figure B.3**  
**Field Wiring Arm Connection Diagram for 1771-AS, -ASB**  
**series A, B, C and D**

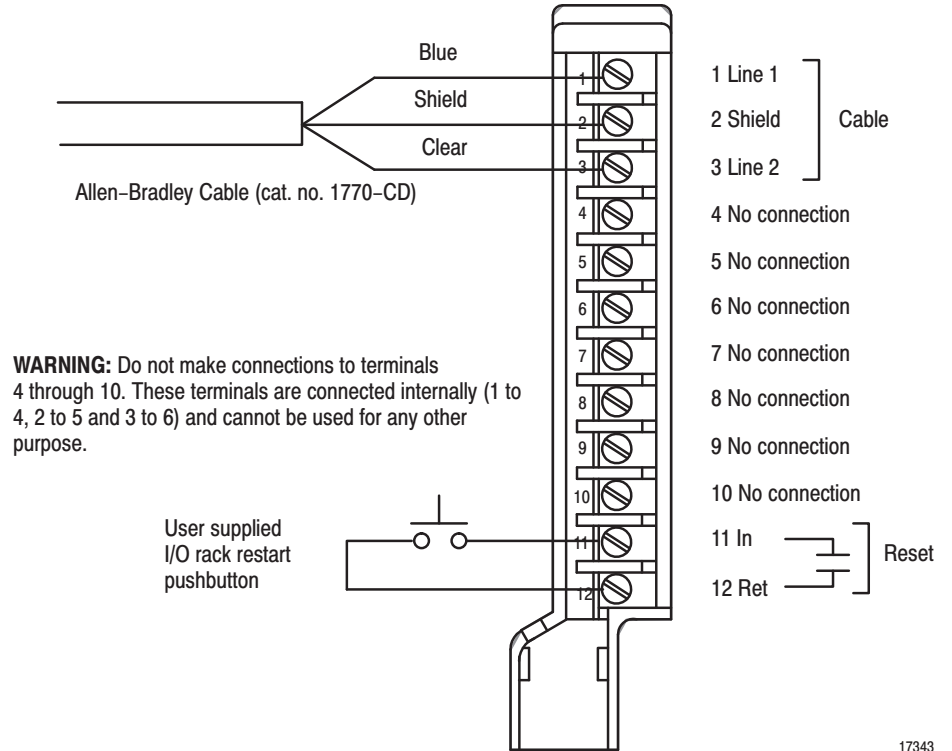

17343

**Figure B.4**  
**Module Switch Assembly Settings for 1771-AS, -ASB series**  
**A and B Adapter for PLC-2 Family Processors**

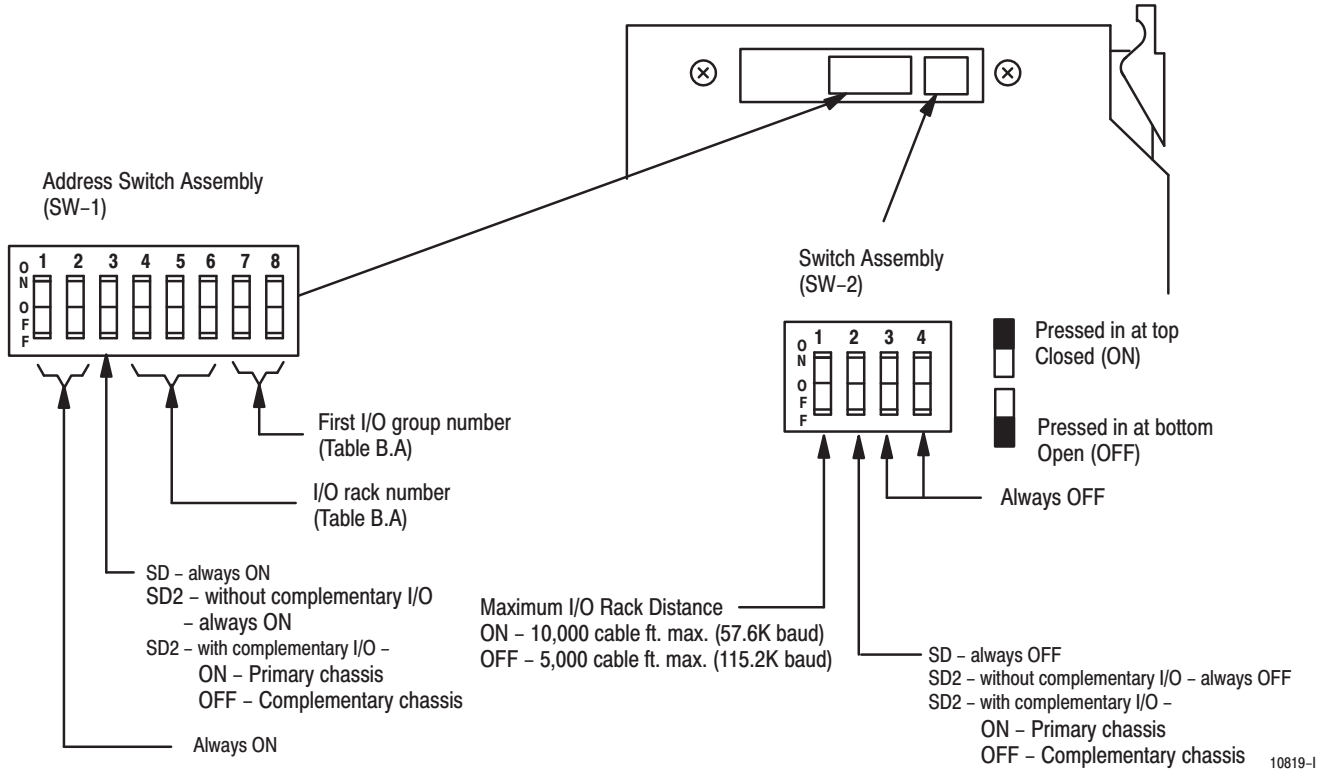

**Table B.A**  
**I/O Rack Selection for PLC-2 Family Processors**

I/O Rack Number	Switch Selections			First I/O Group Number	Switch Selections	
	4	5	6		7	8
1	On	On	On	0	On	On
2	On	On	Off	2	On	Off
3	On	Off	On	4	Off	On
4	On	Off	Off	6	Off	Off
5	Off	On	On			
6	Off	On	Off			
7	Off	Off	On			

**Figure B.5**  
**Module Switch Assembly Settings for 1771-ASB series C**  
**and D Adapters for PLC-2 Family Processors**

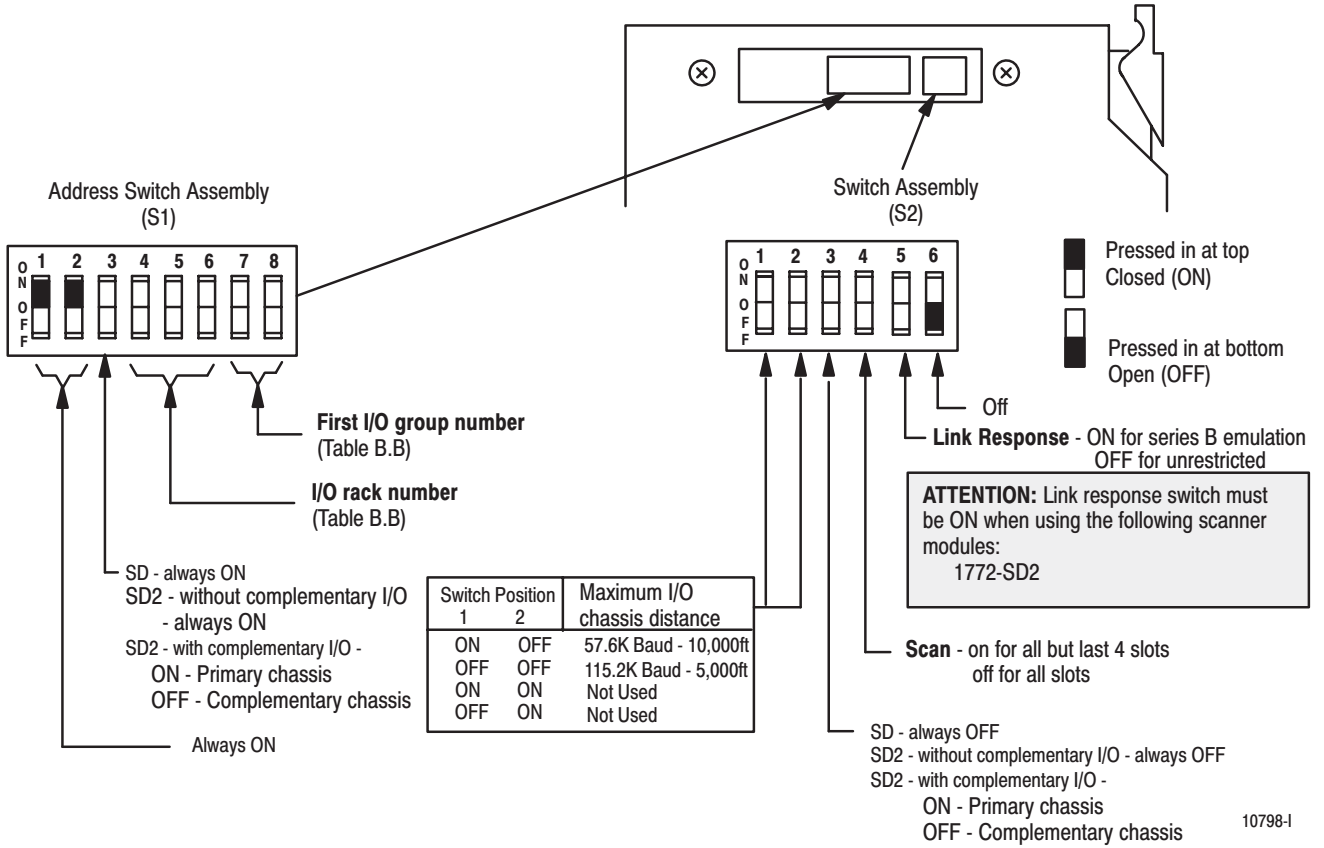

10798-1

**Table B.B**  
**I/O Rack Number and First I/O Group Switch Selections for**  
**the Address Switch Assembly S1 (PLC-2 Family Processors)**

I/O Rack Number	Switch Selections			First I/O Group Number	Switch Selections	
	4	5	6		7	8
1	On	On	On	0	On	On
2	On	On	Off	2	On	Off
3	On	Off	On	4	Off	On
4	On	Off	Off	6	Off	Off
5	Off	On	On			
6	Off	On	Off			
7	Off	Off	On			

**Figure B.6**  
**Module Switch Assembly Settings for 1771-AS and**  
**1771-ASB series A and B Adapters for PLC-3 Family**  
**Processors**

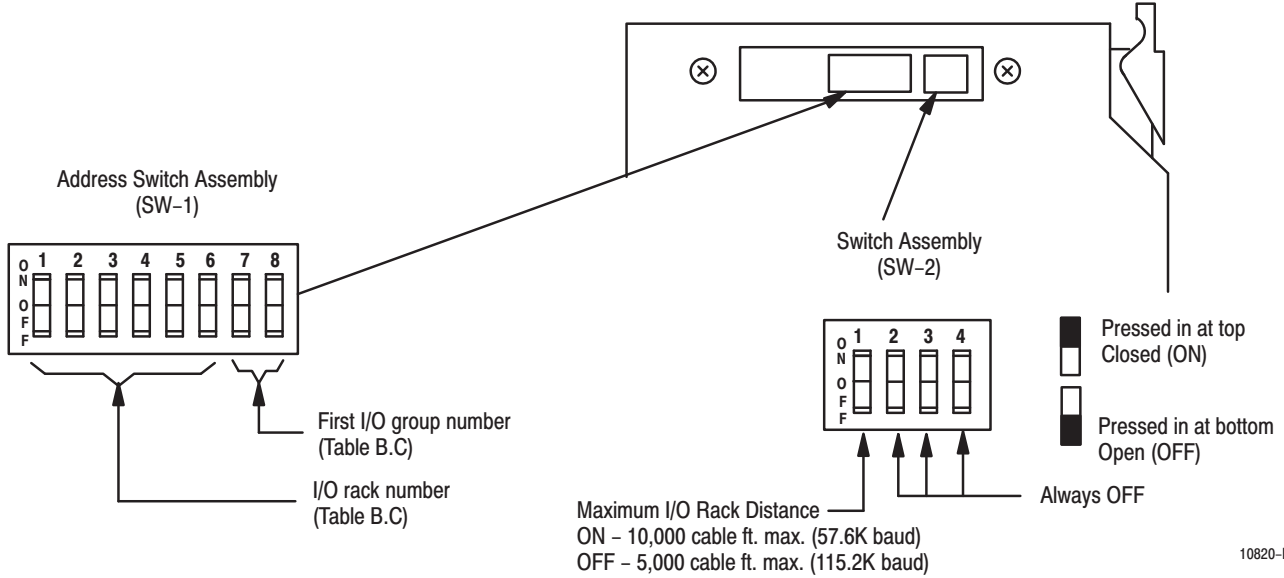

10820-1

**Table B.C**  
**I/O Rack Selection for PLC-3 Family Processors**

I/O Rack Number	Switch Setting						I/O Rack Number	Switch Setting						1st I/O Group Number	Switch Selections	
	1	2	3	4	5	6		1	2	3	4	5	6		7	8
00	On	On	On	On	On	On	20	On	Off	On	On	On	On	0	On	On
01	On	On	On	On	On	Off	21	On	Off	On	On	On	Off	2	On	Off
02	On	On	On	On	Off	On	22	On	Off	On	On	Off	On	4	Off	On
03	On	On	On	On	Off	Off	23	On	Off	On	On	Off	Off	6	Off	Off
04	On	On	On	Off	On	On	24	On	Off	On	Off	On	On			
05	On	On	On	Off	On	Off	25	On	Off	On	Off	On	Off			
06	On	On	On	Off	Off	On	26	On	Off	On	Off	Off	On			
07	On	On	On	Off	Off	Off	27	On	Off	On	Off	Off	Off			
10	On	On	Off	On	On	On	30	On	Off	Off	On	On	On			
11	On	On	Off	On	On	Off	31	On	Off	Off	On	On	Off			
12	On	On	Off	On	Off	On	32	On	Off	Off	On	Off	On			
13	On	On	Off	On	Off	Off	33	On	Off	Off	On	Off	Off			
14	On	On	Off	Off	On	On	34	On	Off	Off	Off	On	On			
15	On	On	Off	Off	On	Off	35	On	Off	Off	Off	On	Off			
16	On	On	Off	Off	Off	On	36	On	Off	Off	Off	Off	On			
17	On	On	Off	Off	Off	Off	37	On	Off	Off	Off	Off	Off			

**Figure B.7**  
**Module Switch Assembly Settings for 1771-ASB series C**  
**and D Adapters for PLC-3 Family Processors**

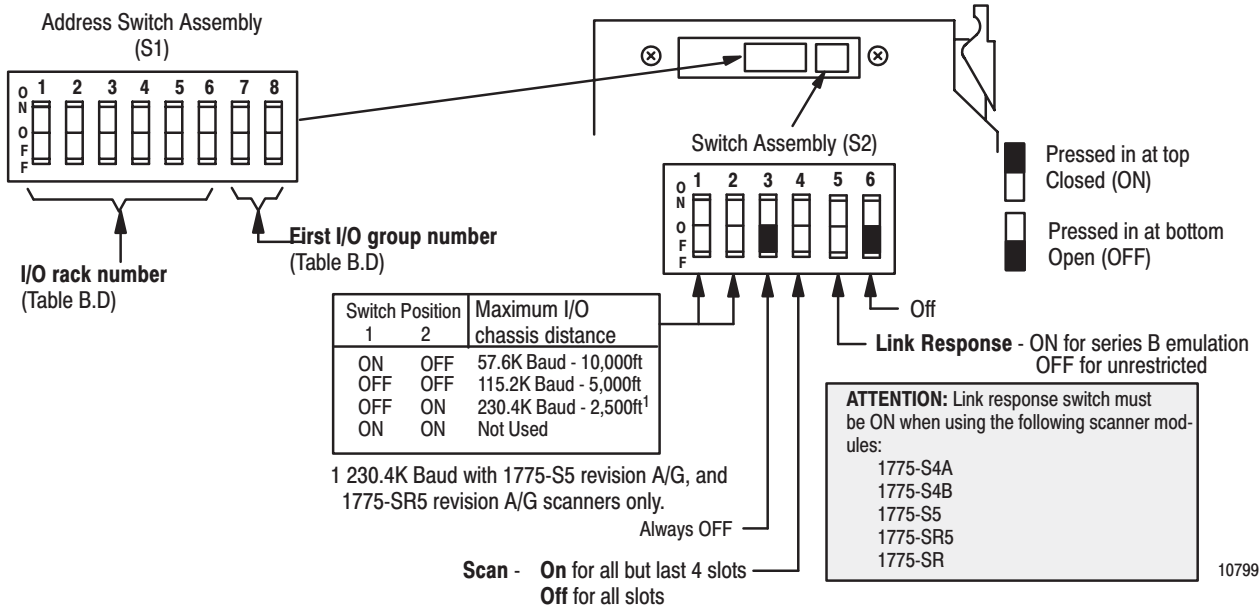

10799-1

**Table B.D**  
**I/O Rack Switch Selections for the Address Switch**  
**Assembly (PLC-3 Family Processors)**

Rack #	Switch Setting						Rack #	Switch Setting						Rack #	Switch Setting											
	1	2	3	4	5	6		1	2	3	4	5	6		1	2	3	4	5	6						
00	On	On	On	On	On	On	20	On	Off	On	On	On	On	40	Off	On	On	On	On	60	Off	Off	On	On	On	On
01	On	On	On	On	On	Off	21	On	Off	On	On	On	Off	41	Off	On	On	On	On	61	Off	Off	On	On	On	Off
02	On	On	On	On	Off	On	22	On	Off	On	On	Off	On	42	Off	On	On	On	Off	62	Off	Off	On	On	Off	On
03	On	On	On	On	Off	Off	23	On	Off	On	On	Off	Off	43	Off	On	On	On	Off	63	Off	Off	On	On	Off	Off
04	On	On	On	Off	On	On	24	On	Off	On	Off	On	On	44	Of	On	On	Off	On	64	Off	Off	On	Off	On	On
05	On	On	On	Off	On	Off	25	On	Off	On	Off	On	Off	45	Off	On	On	Off	On	65	Off	Off	On	Off	On	Off
06	On	On	On	Off	Off	On	26	On	Off	On	Off	Off	On	46	Off	On	On	Off	Off	66	Off	Off	On	Off	Off	On
07	On	On	On	Off	Off	Off	27	On	Off	On	Off	Off	Off	47	Off	On	On	Off	Off	67	Off	Off	On	Off	Off	Off
10	On	On	Off	On	On	On	30	On	Off	Off	On	On	On	50	Off	On	Off	On	On	70	Off	Off	Off	On	On	On
11	On	On	Off	On	On	Off	31	On	Off	Off	On	On	Off	51	Off	On	Off	On	On	71	Off	Off	Off	On	On	Off
12	On	On	Off	On	Off	On	32	On	Off	Off	On	Off	On	52	Off	On	Off	On	Off	72	Off	Off	Off	On	Off	On
13	On	On	Off	On	Off	Off	33	On	Off	Off	On	Off	Off	53	Off	On	Off	On	Off	73	Off	Off	Off	On	Off	Off
14	On	On	Off	Off	On	On	34	On	Off	Off	Off	On	On	54	Off	On	Off	Off	On	74	Off	Off	Off	Off	On	On
15	On	On	Off	Off	On	Off	35	On	Off	Off	Off	On	Off	55	Off	On	Off	Off	On	75	Off	Off	Off	Off	On	Off
16	On	On	Off	Off	Off	On	36	On	Off	Off	Off	Off	On	56	Off	On	Off	Off	Off	76	Off	Off	Off	Off	Off	On
17	On	On	Off	Off	Off	Off	37	On	Off	Off	Off	Off	Off	57	Off	On	Off	Off	Off	77	Not valid					

1st I/O Group Number	Switch Selections	
	7	8
0	On	On
2	On	Off
4	Off	On
6	Off	Off

Note: Rack address 77 is an illegal configuration.  
 PLC-3 processors can scan racks 0-76.

**Figure B.8**  
**Module Switch Assembly Settings for 1771-AS and**  
**1771-ASB series A and B Adapters for PLC-5 Family**  
**Processors without Complementary I/O**

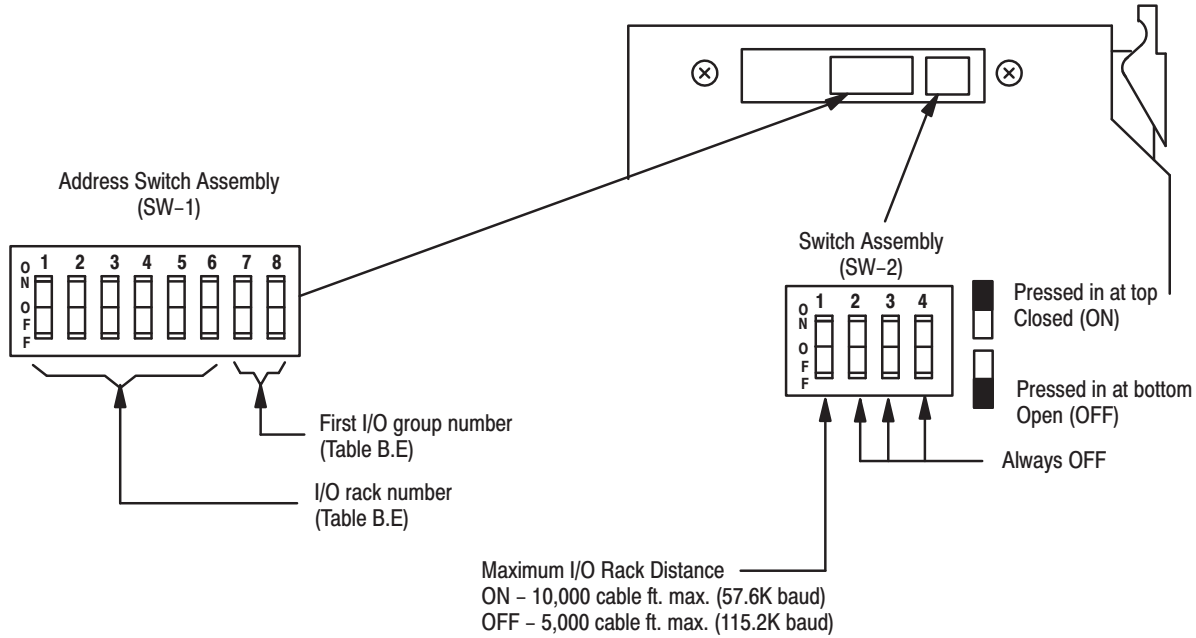

10821-I

**Table B.E**  
**I/O Rack Selection for PLC-5 Family without**  
**Complementary I/O**

I/O Rack Number	Switch Selections						First I/O Group Number	Switch Selections	
	1	2	3	4	5	6		7	8
1	On	On	On	On	On	Off	0	On	On
2	On	On	On	On	Off	On	2	On	Off
3	On	On	On	On	Off	Off	4	Off	On
4 <sup>1</sup>	On	On	On	Off	On	On	6	Off	Off
5 <sup>1</sup>	On	On	On	Off	On	Off			
6 <sup>1</sup>	On	On	On	Off	Off	On			
7 <sup>1</sup>	On	On	On	Off	Off	Off			

<sup>1</sup> Valid for PLC-5/25 processors only

**Figure B.9**  
**Module Switch Assembly Settings for 1771-ASB series C**  
**and D Adapters for PLC-5 Family Processors Without**  
**Complementary I/O**

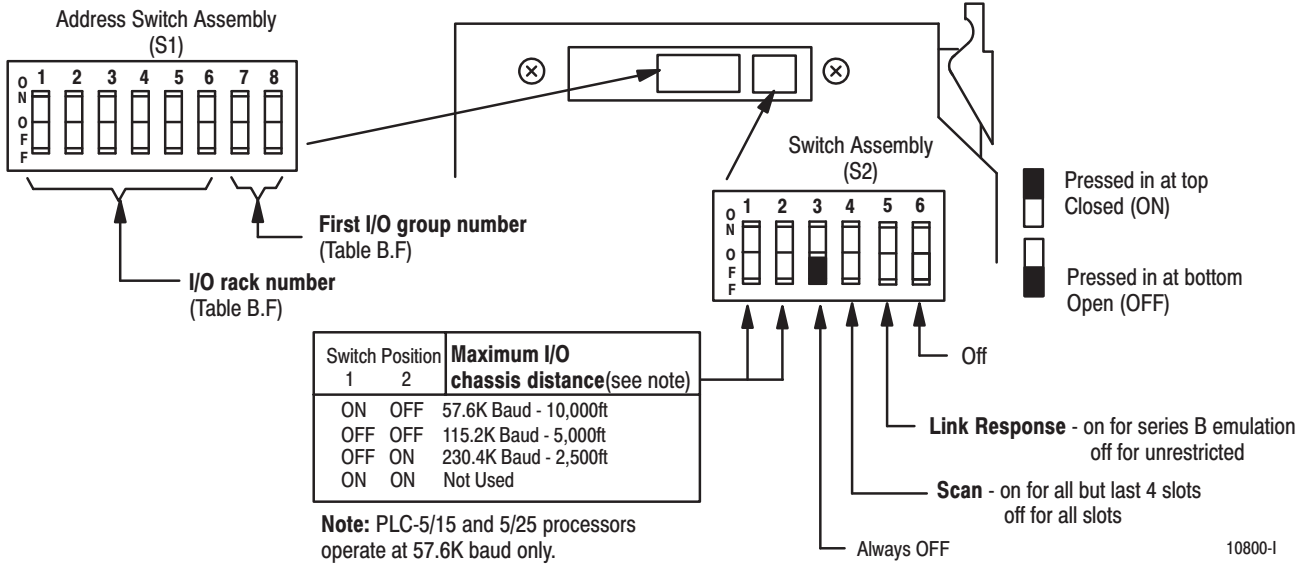
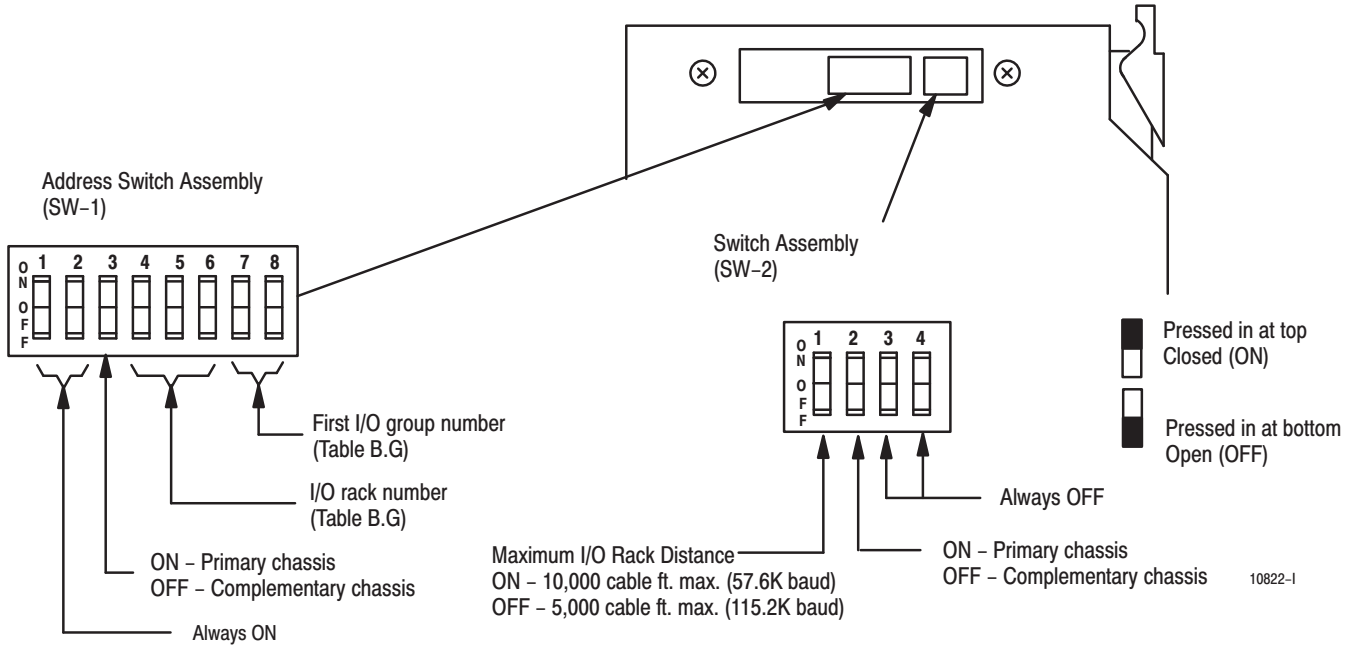

**Table B.F**  
**I/O Rack Selection for PLC-5 Family Processors**  
**without Complementary I/O**

Rack #	Switch Setting						Rack #	Switch Setting						1st I/O Group Number	Switch Selections	
	1	2	3	4	5	6		1	2	3	4	5	6		7	8
00	On	On	On	On	On	On	20	On	Off	On	On	On	On	0	On	On
01	On	On	On	On	On	Off	21	On	Off	On	On	On	Off	2	On	Off
02	On	On	On	On	Off	On	22	On	Off	On	On	Off	On	4	Off	On
03	On	On	On	On	Off	Off	23	On	Off	On	On	Off	Off	6	Off	Off
04	On	On	On	Off	On	On	24	On	Off	On	Off	On	On			
05	On	On	On	Off	On	Off	25	On	Off	On	Off	On	Off			
06	On	On	On	Off	Off	On	26	On	Off	On	Off	Off	On			
07	On	On	On	Off	Off	Off	27	On	Off	On	Off	Off	Off			
10	On	On	Off	On	On	On	30	On	Off	Off	On	On	On			
11	On	On	Off	On	On	Off	31	On	Off	Off	On	On	Off			
12	On	On	Off	On	Off	On	32	On	Off	Off	On	Off	On			
13	On	On	Off	On	Off	Off	33	On	Off	Off	On	Off	Off			
14	On	On	Off	Off	On	On	34	On	Off	Off	Off	On	On			
15	On	On	Off	Off	On	Off	35	On	Off	Off	Off	On	Off			
16	On	On	Off	Off	Off	On	36	On	Off	Off	Off	Off	On			
17	On	On	Off	Off	Off	Off	37	On	Off	Off	Off	Off	Off			

PLC-5/11 processors can scan rack 03.  
 PLC-5/15 and PLC-5/20 processors can scan racks 01-03.  
 PLC-5/25 and PLC-5/30 processors can scan racks 01-07.  
 PLC-5/40 and PLC-5/40L processors can scan racks 01-17.  
 PLC-5/60 and PLC-5/60L processors can scan racks 01-27.  
 PLC-5/250 processors can scan racks 0-37.

**Figure B.10**  
**Module Switch Assembly Settings for 1771-AS, -ASB series**  
**A and B Adapters for PLC-5 Family Processors with**  
**Complementary I/O**

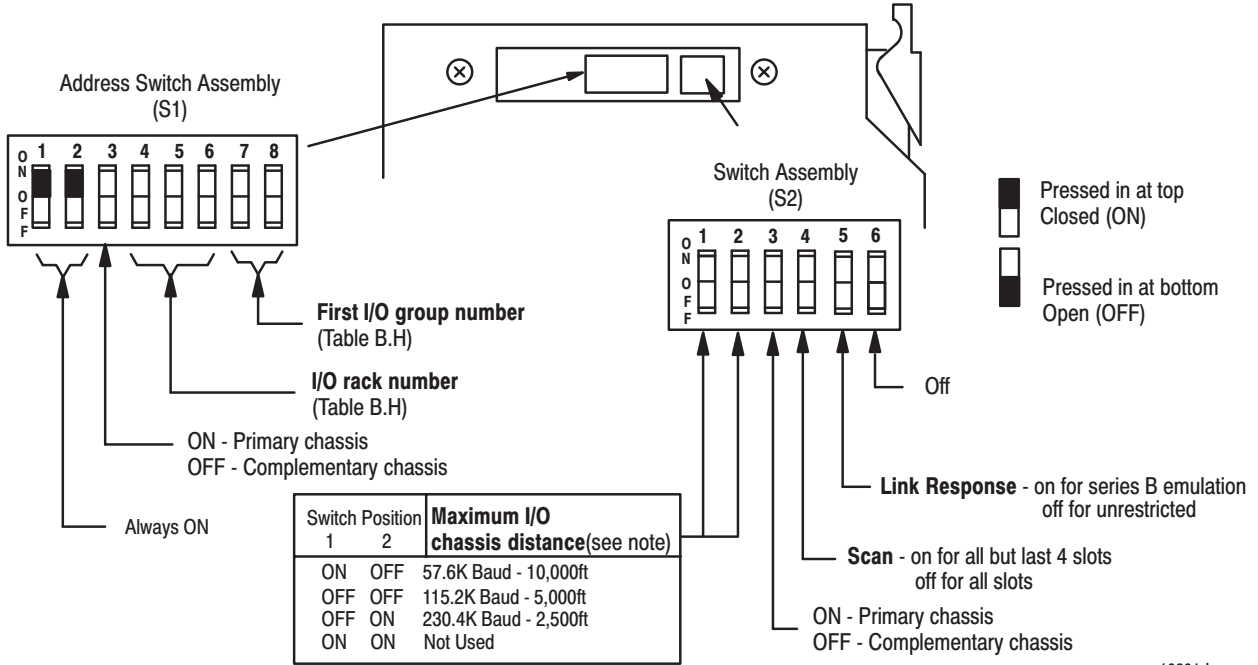

**Table B.G**  
**I/O Rack Selection for PLC-5 Family with Complementary I/O**

I/O Rack Number	Switch Selections			First I/O Group Number	Switch Selections	
	4	5	6		7	8
1	On	On	Off	0	On	On
2	On	Off	On	2	On	Off
3	On	Off	Off	4	Off	On
4 <sup>1</sup>	Off	On	On	6	Off	Off
5 <sup>1</sup>	Off	On	Off			
6 <sup>1</sup>	Off	Off	On			
7 <sup>1</sup>	Off	Off	Off			

<sup>1</sup> Valid for PLC-5/25 processors only

**Figure B.11**  
**Module Switch Assembly Settings for 1771-ASB series C**  
**and D Adapters for PLC-5 Family Processors With**  
**Complementary I/O**



10801-I

**Table B.H**  
**I/O Rack Selection for PLC-5 Family Processors with**  
**Complementary I/O**

I/O Rack #	Switch						1st I/O Group Number	Switch Selections	
	1	2	3	4	5	6		7	8
01	On	On	On	On	On	Off	0	On	On
02	On	On	On	On	Off	On	2	On	Off
03	On	On	On	On	Off	Off	4	Off	On
							6	Off	Off
04	On	On	On	Off	On	On			
05	On	On	On	Off	On	Off			
06	On	On	On	Off	Off	On			
07	On	On	On	Off	Off	Off			
See note below									

**Note:** PLC-5/11 can scan rack 03.  
 PLC-5/20, PLC-5/30, PLC-5/40, PLC-5/60 can scan racks 01-07.

**Figure B.12**  
**I/O Chassis Backplane Switch Assembly Settings for**  
**1771-AS Remote Adapter Module in PLC-2 Family**  
**Processor System**

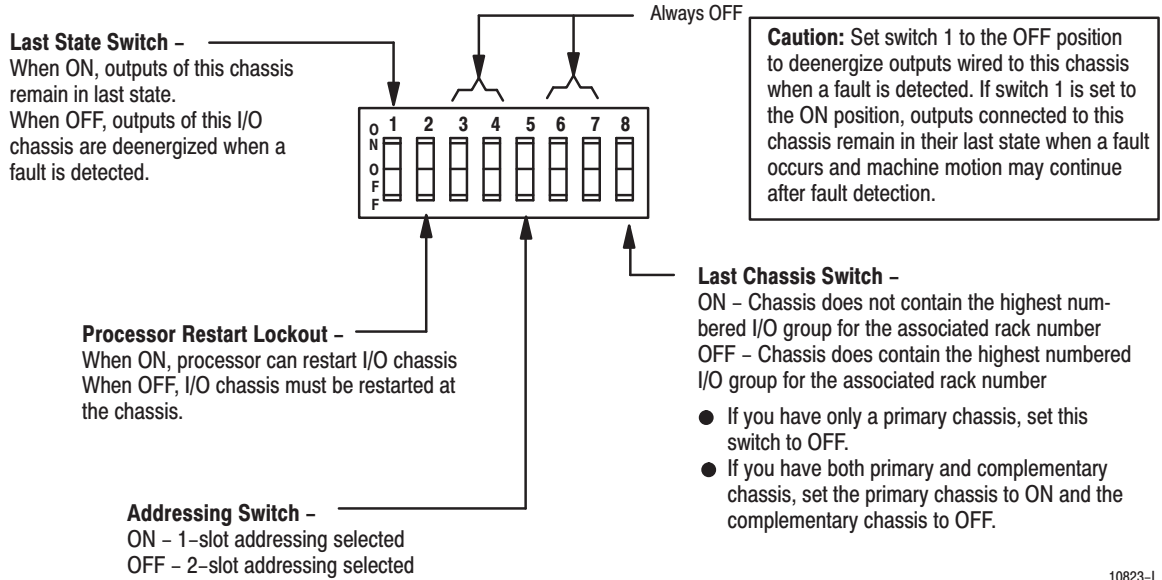

10823-1

**Figure B.13**  
**I/O Chassis Backplane Switch Assembly Settings for**  
**1771-AS Remote Adapter Module in PLC-3 Family**  
**Processor System**

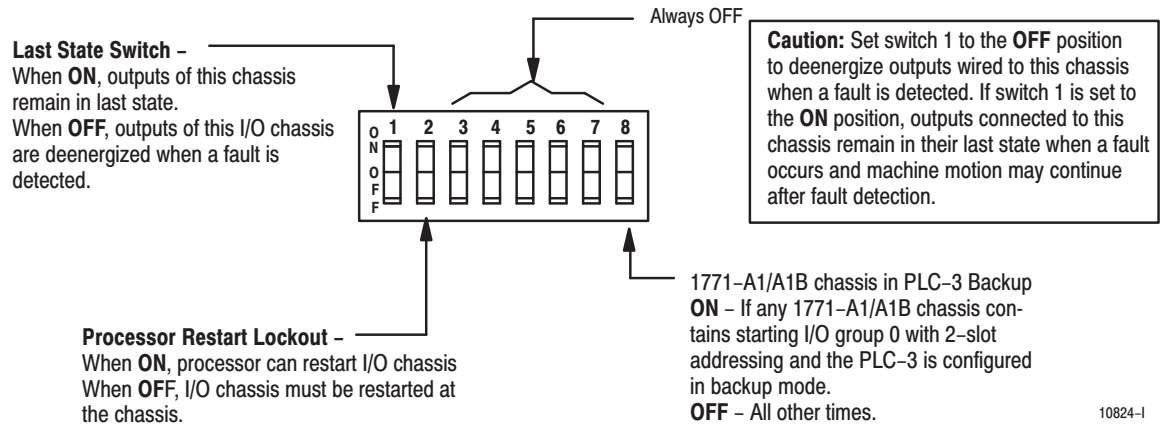

10824-1

**Figure B.14**  
I/O Chassis Backplane Switch Assembly Settings for 1771-ASB series C and D Remote Adapter Module in PLC-2 Family Processor System

**Last State Switch -**

When ON, outputs of this chassis remain in last state.  
When OFF, outputs of this I/O chassis are deenergized when a fault is detected.

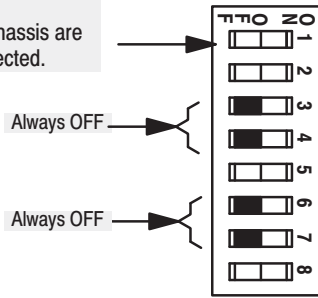

**Processor Restart Lockout -**

When ON, processor can restart I/O chassis  
When OFF, I/O chassis must be restarted at the chassis.

**Addressing Switch -**

ON - 1-slot addressing selected  
OFF - 2-slot addressing selected

**Last Chassis Switch -**

ON - Chassis does not contain the highest numbered I/O group for the associated rack number  
OFF - Chassis does contain the highest numbered I/O group for the associated rack number

- If you have only a primary chassis, set this switch to OFF.
- If you have both primary and complementary chassis, set the primary chassis to ON and the complementary chassis to OFF.

**ATTENTION:** Set switch 1 to the OFF position to deenergize outputs wired to this chassis when a fault is detected. If switch 1 is set to the ON position, outputs connected to this chassis remain in their last state when a fault occurs and machine motion may continue after fault detection.

1080

**Figure B.15**  
I/O Chassis Backplane Switch Assembly Settings for 1771-ASB series C and D Remote Adapter Module in PLC-3 Family Processor System

**ATTENTION:** Set switch 1 to the OFF position to deenergize outputs wired to this chassis when a fault is detected. If switch 1 is set to the ON position, outputs connected to this chassis remain in their last state when a fault occurs and machine motion may continue after fault detection.

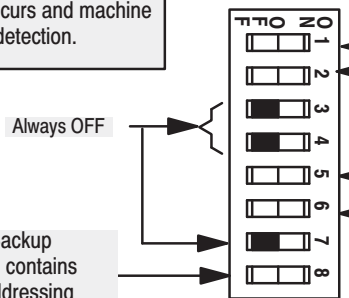

**Last State Switch -**

When ON, outputs of this chassis remain in last state.  
When OFF, outputs of this I/O chassis are deenergized when a fault is detected.

**Processor Restart Lockout -**

When ON, processor can restart I/O chassis  
When OFF, I/O chassis must be restarted at the chassis.

**1771-A1/A1B chassis in PLC-3 Backup**  
**ON** - If any 1771-A1/A1B chassis contains starting I/O group 0 with 2-slot addressing and the PLC-3 is configured in backup mode.  
**OFF** - All other times.

Addressing Switches		
5	6	
OFF	ON	You select 1/2-slot addressing
ON	OFF	You select 1-slot addressing
OFF	OFF	You select 2-slot addressing
ON	ON	Not allowed

10802-1

**Figure B.16**  
**I/O Chassis Backplane Switch Assembly Settings for**  
**1771-ASB series C and D Remote Adapter Module in PLC-5**  
**Family, SLC and ControlLogix Processor System**

**ATTENTION:** Set switch 1 to the **OFF** position to deenergize outputs wired to this chassis when a fault is detected. If switch 1 is set to the **ON** position, outputs connected to this chassis remain in their last state when a fault occurs and machine motion may continue after fault detection.

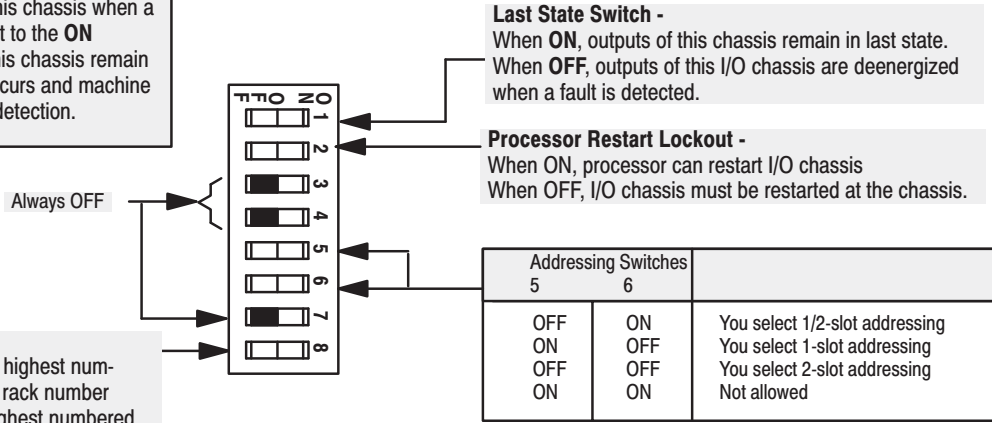

**Last Chassis Switch -**  
 ON - Chassis does not contain the highest numbered I/O group for the associated rack number  
 OFF - Chassis does contain the highest numbered I/O group for the associated rack number

- If you have only a primary chassis, set this switch to OFF.
- If you have both primary and complementary chassis, set the primary chassis to ON and the complementary chassis to OFF.

10802-1

**Figure B.17**  
**I/O Chassis Backplane Switch Assembly Settings for**  
**1771-ASB series C and D Remote Adapter Module in PLC-5**  
**Family, SLC and ControlLogix Processor Systems in**  
**Remote Configuration**

**ATTENTION:** If switch 1 is set to the **ON** position, outputs connected to this chassis remain in their last state when a fault occurs and machine motion may continue after fault detection. We recommend that you set switch 1 to the **OFF** position to deenergize outputs wired to this chassis when a fault is detected.

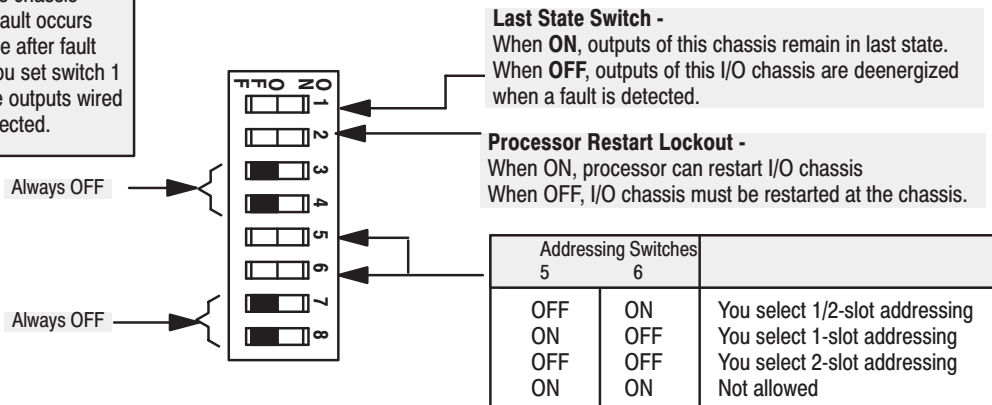

10802-1

**Figure B.18**  
**I/O Chassis Backplane Switch Assembly Settings for**  
**1771-ASB series C and D Remote Adapter Module in**  
**PLC-5/250 Processor System**

**ATTENTION:** Set switch 1 to the **OFF** position to deenergize outputs wired to this chassis when a fault is detected. If switch 1 is set to the **ON** position, outputs connected to this chassis remain in their last state when a fault occurs and machine motion may continue after fault detection.

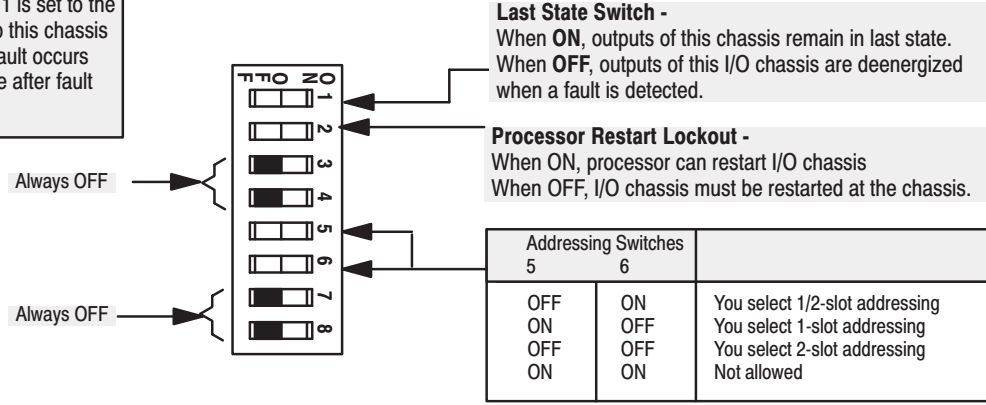

10802-1



## Differences Between 1771-ASB Series A, B, C, D and E Remote I/O Adapter Modules

Major differences between series are noted in the table below.

**Table C.A**  
Major Differences Between 1771-ASB Series Adapters

1771-ASB	Series A	Series B	Series C	Series D	Series E
Functional Changes	Initial release	Firmware change	Hardware and firmware change	Firmware change Added CE certification	Hardware change Added C-Tick certification
Restrictions or limitations	Supports only 1 or 2 slot addressing	Supports 1/2, 1 or 2 slot addressing			
Hardware Compatibility	Does not support 32 bit digital I/O	Does support 32 bit digital I/O		Does support 32 bit digital I/O Can emulate series B adapter	
Communication Rate	57.6kbits/s 115.2kbits/s		57.6kbits/s 115.2kbits/s 230.4kbits/s		
Certifications	CSA Hazardous Class I, Div 2			CSA Hazardous Class I, Div 2 CE	
Backplane Current	1.2A @ 5V dc		1.0A @ 5V dc		
Chassis Distance	5,000ft @ 115.2kbits/s 10,000ft @ 57.6kbits/s		5,000ft @ 115.2kbits/s 10,000ft @ 57.6kbits/s 2,500ft @ 230.4kbits/s		
Thermal Dissipation	20.47 BTU/hr		17.06 BTU/hr		
Power Dissipation	6W		5W		



---

## Questions and Answers

This appendix presents some of the most commonly asked questions about application and operation of the Remote I/O Adapter Module.

### Questions and Answers

The following questions and answers do not cover all possible questions, but are representative of the more common ones.

- Q.** What happens to my inputs and outputs when an adapter communication failure occurs?
- A.** On a communication failure, inputs in this rack will appear in the processor input image table in the last state they were reported to be in before the failure. Outputs in this rack will either remain in their last state or be turned off, depending on the I/O chassis backplane switch setting for output last state.
- Q.** Is there a way to monitor my remote rack status and take appropriate action if there is a rack fault or a communication failure?
- A.** Yes. Processor rack fault bits can be monitored. Communication failure can be detected by monitoring the program's block transfer error bit. A diagnostic step array and timer can be programmed to monitor the status of changing digital inputs. In all cases, the appropriate action can be taken, i.e. program a fault routine.
- Q.** I just replaced my series B adapter with a series E adapter, and now my block transfers are timing out (block transfer error code -9). What's wrong?
- A.** Certain scanner modules require series B emulation which includes a delay to provide the scanner sufficient time to service all of its communication ports. If you are using a 1772-SD2, 1775-S4, 1775-S4A, 1775-S5, 1775-SR5 or 1775-SR scanner, set the link response for unrestricted or series B emulation (switch S2, position 5 on).

**Q.** I just added a rack to my remote I/O network and my PLC-5 scanner channel autoconfiguration does not recognize it. Why not?

**A.** This is typically the result of installation and configuration problems. Anything from adapter power, wiring and connections, terminations, improper setting of adapter and chassis module switches. Use the scanner and adapter status indicators as a troubleshooting tool. Easy checks include 1.) installing a known to be good adapter into this chassis, or 2.) start from scratch by saving the program, clearing the processor memory by removing the battery, creating an I/O status file, configuring the scanner channel and autoconfigure. Sometimes just creating a new I/O status file works. You could also check this adapter alone with the scanner without a program in the processor, and without a module in the chassis. Also, insure that the processor and its I/O image table support the rack address you are adding and that the rack inhibit bit is not set. Expand the image table and remove the rack inhibit as necessary.

**Q.** I am adding a new remote rack to my RIO network. Do I have to shut my process down to install it?

**A.** Yes, the processor must be in Program mode to either manually add or autoconfigure remote I/O devices on the network.

**Q.** I just added a rack to my RIO network and my block transfer data throughput has slowed down considerably. Why?

**A.** Block transfer throughput is determined by a number of things, including how many adapters are on the network, how many block transfer modules are in each chassis, communication rate and number of block transfer words being transferred. Refer to your processor user manual to determine the worst case throughput and recommendations on how to optimize throughput.

**Q.** I am adding a new remote rack to my RIO network. Since this rack is in close proximity to one of my adapters in the middle of my link, can I wire it directly to that adapter?

**A.** No, you can't. Star connections are not allowed on remote I/O. Daisy-chain or trunkline-dropline configurations are the only ones permitted.





- 
- Q.** My remote I/O is working fine without termination resistors. Are they really required?
- A.** Yes, termination resistors are required. Any change in the RIO network installation (i.e. cable length, baud rate) can cause a remote I/O communication failure without proper termination. Installing termination resistors reduces the chance of this occurring.
- Q.** I have an existing PLC remote I/O system that I'm replacing with 1771. Are the new adapters compatible with the older processors?
- A.** Any remote I/O adapter is compatible with any processor. Any and all series/revisions of remote I/O adapter devices can be mixed on the blue hose. Make sure you set the adapter switches correctly, since switch positions may have changed on later adapters. Also, older racks and adapters only support 2 slot addressing and 8 pt. modules, while newer racks and adapters and racks have no such restrictions.
- Q.** I'm replacing an existing PLC-2 remote I/O system with new PLC-5 processors. Will the new processors work with the older 1771-ASB adapters?
- A.** Again, any processor will work with any series/revision remote I/O adapter. Watch your switch settings. Old power supplies can be used to power your adapters, but cannot be used to power the rack containing a PLC-5 processor. PLC-5 processors must be powered by slot power supplies or by a 1771-P7 supply.
- Q.** Specifications for my processor state that it can support 24 logical racks, but it won't accept any rack addresses over rack 17 (16 physical racks).
- A.** This is a processor limitation. Each RIO channel is limited to 16 logical racks which can be scanned by the channel. The additional racks can be scanned on another RIO channel, if practical.
- Q.** How do I add a 1771-ASB adapter module to my ControlLogix remote I/O network?
- A.** Simply add the adapter under the 1756-DHRIO scanner in the Logix5550 Controller Organizer I/O configuration tree. With the scanner, adapter and chassis switches set correctly, download the program to the Logix5550 processor and switch to Run mode. Communication to the adapter will commence.

- Q.** How do I add a 1771-ASB adapter module to my SLC 1747-SN scanner remote I/O network?
- A.** Enter the correct rack number, rack size and starting group in the SLC500 program I/O configuration G-file data screen. With the correct communication rate set on the scanner, download the program to the SLC processor and switch to Run mode. Communication to the adapter will commence.
- Q.** Ever since I installed fiber optics on my remote I/O network, the adapters won't communicate.
- A.** This is probably an installation issue. Check your installation for the correct application, connection and termination of fiber optic cable, and the correct setup of the fiber optic module (1771-AF, -AF1). Make sure that no length of blue hose on this network is less than 10ft long, including the blue hose connections from the processor, scanner or adapter to the fiber optic module in the same chassis.
- Q.** I have a 12-slot chassis but only the modules in the first 8 slots are recognized by my program.
- A.** Check the scan switch (switch S2, position 4) for correct setting. It probably is set ON "scan all but the last 4 slots." Set it to OFF.
- Q.** I just installed a 1771-IL series B analog input module in my remote I/O chassis which already has a 1771-ASB series A adapter. Now my block transfers to this module are erroring.
- A.** Adapter modules prior to series C, firmware revision D, are not compatible with the following modules:
- 1771-CFM, -CFMK Series A
  - 1771-DB Series B
  - 1771-DMC Series A
  - 1771-DMC1 Series A
  - 1771-DMC4 Series A
  - 1771-DXS2 Series A
  - 1771-DXS4 Series A
  - 1771-HS1, -HS3A, -HS3CR
  - 1771-IFE Series C
  - 1771-IFM Series A and B
  - 1771-IL, -ILK Series B
  - 1771-IR, -IRK Series B
  - 1771-IXE, -IXEK Series B
  - 1771-IXHR Series B
  - 1771-NXXX Series A
  - 1771-OEM1 Series A
  - 1771-QB Series B

1771-QD Series A and B  
1771-QDC Series A  
1771-QH Series A  
1771-TCM Series A  
1771-VHSC, VHSCK Series A  
1771-WS Series A

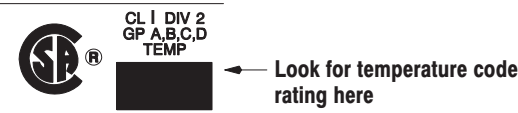
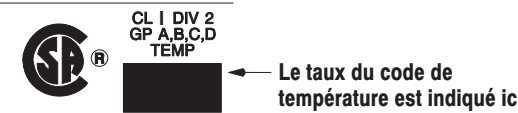

## CSA Hazardous Location Approval

CSA Hazardous Location Approval	Approbation d'utilisation dans des emplacements dangereux par la CSA
<p>CSA® certifies products for general use as well as for use in hazardous locations. <b>Actual CSA certification is indicated by the product label</b> as shown below, and not by statements in any user documentation.</p>	<p>La CSA® certifie les produits d'utilisation générale aussi bien que ceux qui s'utilisent dans des emplacements dangereux. <b>La certification CSA en vigueur est indiquée par l'étiquette du produit</b> et non par des affirmations dans la documentation à l'usage des utilisateurs.</p>
<p><b>Example of the CSA certification product label</b></p> 	<p><b>Exemple d'étiquette de certification d'un produit par la CSA</b></p> 
<p>To comply with CSA certification for use in hazardous locations, the following information becomes a part of the product literature for CSA-certified Allen-Bradley industrial control products.</p> <ul style="list-style-type: none"> <li>This equipment is suitable for use in Class I, Division 2, Groups A, B, C, D, or non-hazardous locations only.</li> <li>The products having the appropriate CSA markings (that is, Class I Division 2, Groups A, B, C, D), are certified for use in other equipment where the suitability of combination (that is, application or use) is determined by the CSA or the local inspection office having jurisdiction.</li> </ul>	<p>Pour satisfaire à la certification de la CSA dans des endroits dangereux, les informations suivantes font partie intégrante de la documentation des produits industriels de contrôle Allen-Bradley certifiés par la CSA.</p> <ul style="list-style-type: none"> <li>Cet équipement convient à l'utilisation dans des emplacements de Classe 1, Division 2, Groupes A, B, C, D, ou ne convient qu'à l'utilisation dans des endroits non dangereux.</li> <li>Les produits portant le marquage approprié de la CSA (c'est à dire, Classe 1, Division 2, Groupes A, B, C, D) sont certifiés à l'utilisation pour d'autres équipements où la convenance de combinaison (application ou utilisation) est déterminée par la CSA ou le bureau local d'inspection qualifié.</li> </ul>
<p><b>Important:</b> Due to the modular nature of a PLC® control system, the product with the highest temperature rating determines the overall temperature code rating of a PLC control system in a Class I, Division 2 location. The temperature code rating is marked on the product label as shown.</p>	<p><b>Important:</b> Par suite de la nature modulaire du système de contrôle PLC®, le produit ayant le taux le plus élevé de température détermine le taux d'ensemble du code de température du système de contrôle d'un PLC dans un emplacement de Classe 1, Division 2. Le taux du code de température est indiqué sur l'étiquette du produit.</p>
<p><b>Temperature code rating</b></p> 	<p><b>Taux du code de température</b></p> 
<p>The following warnings apply to products having CSA certification for use in hazardous locations.</p>	<p>Les avertissements suivants s'appliquent aux produits ayant la certification CSA pour leur utilisation dans des emplacements dangereux.</p>
 <p><b>WARNING:</b> Explosion hazard —</p> <ul style="list-style-type: none"> <li>Substitution of components may impair suitability for Class I, Division 2.</li> <li>Do not replace components unless power has been switched off or the area is known to be non-hazardous.</li> <li>Do not disconnect equipment unless power has been switched off or the area is known to be non-hazardous.</li> <li>Do not disconnect connectors unless power has been switched off or the area is known to be non-hazardous. Secure any user-supplied connectors that mate to external circuits on an Allen-Bradley product using screws, sliding latches, threaded connectors, or other means such that any connection can withstand a 15 Newton (3.4 lb.) separating force applied for a minimum of one minute.</li> </ul>	 <p><b>AVERTISSEMENT:</b> Risque d'explosion —</p> <ul style="list-style-type: none"> <li>La substitution de composants peut rendre ce matériel inacceptable pour les emplacements de Classe I, Division 2.</li> <li>Couper le courant ou s'assurer que l'emplacement est désigné non dangereux avant de remplacer les composants.</li> <li>Avant de débrancher l'équipement, couper le courant ou s'assurer que l'emplacement est désigné non dangereux.</li> <li>Avant de débrancher les connecteurs, couper le courant ou s'assurer que l'emplacement est reconnu non dangereux. Attacher tous connecteurs fournis par l'utilisateur et reliés aux circuits externes d'un appareil Allen-Bradley à l'aide de vis, loquets coulissants, connecteurs filetés ou autres moyens permettant aux connexions de résister à une force de séparation de 15 newtons (3,4 lb. - 1,5 kg) appliquée pendant au moins une minute.</li> </ul>
<p>CSA logo is a registered trademark of the Canadian Standards Association PLC is a registered trademark of Allen-Bradley Company, Inc.</p>	<p>Le sigle CSA est la marque déposée de l'Association des Standards pour le Canada. PLC est une marque déposée de Allen-Bradley Company, Inc.</p>



## A

addressing  
  1-slot, 3-13  
    with 32-point modules, 3-14  
  1/2-slot, 3-19  
  2-slot, 3-3  
    complementary I/O, 3-9  
    using 16-point modules, 3-5  
    with 8-point modules, 3-4  
  I/O groups, 3-2  
  mixing 1 and 2-slot, 3-23  
addressing hardware, 3-1  
assigning I/O rack numbers, with 1/2-slot  
  addressing, 3-20  
autoconfigure, 4-4  
  1747-SN, 4-4  
  1756-DHRIO, 4-4

## B

backplane switch assembly  
  description, 2-9  
  settings for PLC-3 processor, 2-9, 2-10,  
    B-1, B-12, B-13  
  settings for PLC-5/15 in remote  
    configuration, 2-11, B-2, B-14  
  settings for PLC-5/15 processor, 2-10,  
    B-2, B-14  
  settings for PLC-5/250 processor, 2-11,  
    B-2, B-15  
  settings with PLC-2 processor, B-1,  
    B-12

## C

chassis combinations, acceptable, 3-24  
combinations, I/O chassis and adapter,  
  3-25  
complementary I/O, with 1/2-slot  
  addressing, 3-22  
components, hardware, 1-2  
configuration plug, I/O chassis power  
  supply, 2-12  
configuration plugs, 2-2  
connections, additional adapters, 2-13

## D

diagnostic indicators, 1-2

## F

features of module, 1-1  
field wiring arm, 1-3  
  connection points, 2-12  
  connections, 2-12

## I

I/O groups  
  identifying, 3-7  
  identifying with 1-slot addressing, 3-15  
I/O rack number, select using this switch,  
  2-3  
I/O rack number assignment, with 1-slot  
  addressing, 3-17  
indicators, 4-1  
installing the module, 2-15

## K

keying, 2-1

## L

link response, unrestricted or series B  
  emulation, 2-4

## M

module placement  
  1-slot addressing, 3-16  
  2-slot addressing, 3-11

## N

noise immunity, enabling, 2-4  
non-compatible products, 2-14

## P

power requirements, 2-1  
primary/complementary, switch, 2-3

## Q

questions and answers, D-1  
questions/answers, frequently asked, D-1

**S**

- scan all slots/last 4 slots, 2-3
- scanner modules, requiring delay, 2-4
- series B emulation, 1-1
- series differences, adapters, C-1
- specifications, A-1
- switch assemblies, 1-3
  - setting, 2-2
- switch assembly S1, 2-3
  - use to select, 2-3
- switch assembly S2, 2-3
  - use to select, 2-3
- switch locations, 1-3
- switch settings
  - PLC-2, 2-5
  - PLC-2 with -AS, -ASB Series A and B adapter, B-4
  - PLC-2 with Series C adapter, B-5
  - PLC-3, 2-6
  - PLC-3 with -AS and -ASB Series A and B, B-6
  - PLC-3 with -AS, Series A or B adapter, B-8
  - PLC-3 with Series C adapter, B-7
  - PLC-5 with -AS or -ASB Series A, B, with complementary I/O, B-10
  - PLC-5 with complementary I/O, 2-8, B-11
  - PLC-5 with Series C, without complementary I/O, B-9
  - PLC-5 without complementary I/O, 2-7

**T**

- terminating resistor, 2-14
- troubleshooting guide, 4-2
- troubleshooting indicators, 4-1



# Allen-Bradley Publication Problem Report

If you find a problem with our documentation, please complete and return this form.

Pub. Name Remote I/O Adapter User Manual

Cat. No. 1771-ASB Series E Pub. No. 1771-UM001A Pub. Date February 2000 Part No. 957259-94

Check Problem(s) Type:	Describe Problem(s):	Internal Use Only
<input type="checkbox"/> Technical Accuracy	<input type="checkbox"/> text <input type="checkbox"/> illustration	
<input type="checkbox"/> Completeness What information is missing?	<input type="checkbox"/> procedure/step <input type="checkbox"/> illustration <input type="checkbox"/> definition	<input type="checkbox"/> info in manual (accessibility)
	<input type="checkbox"/> example <input type="checkbox"/> guideline <input type="checkbox"/> feature	<input type="checkbox"/> info not in manual
	<input type="checkbox"/> explanation <input type="checkbox"/> other	
<input type="checkbox"/> Clarity What is unclear?		
<input type="checkbox"/> Sequence What is not in the right order?		
<input type="checkbox"/> Other Comments Use back for more comments.		

Your Name \_\_\_\_\_ Location/Phone \_\_\_\_\_

Return to: Marketing Communications, Allen-Bradley Co., 1 Allen-Bradley Drive, Mayfield Hts., OH 44124-6118 Phone: (216)646-3176  
FAX: (216)646-4320

PLEASE FASTEN HERE (DO NOT STAPLE)

Other Comments

PLEASE FOLD HERE

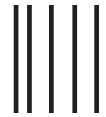

NO POSTAGE  
NECESSARY  
IF MAILED  
IN THE  
UNITED STATES

PLEASE REMOVE

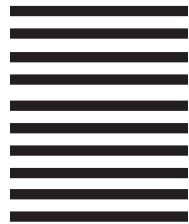

**BUSINESS REPLY MAIL**

FIRST-CLASS MAIL PERMIT NO. 18235 CLEVELAND OH

POSTAGE WILL BE PAID BY THE ADDRESSEE



**Allen-Bradley**

1 ALLEN BRADLEY DR  
MAYFIELD HEIGHTS OH 44124-9705







Allen-Bradley, a Rockwell Automation Business, has been helping its customers improve productivity and quality for more than 90 years. We design, manufacture and support a broad range of automation products worldwide. They include logic processors, power and motion control devices, operator interfaces, sensors and a variety of software. Rockwell is one of the world's leading technology companies.



### Worldwide representation.

Argentina • Australia • Austria • Bahrain • Belgium • Brazil • Bulgaria • Canada • Chile • China, PRC • Colombia • Costa Rica • Croatia • Cyprus • Czech Republic • Denmark • Ecuador • Egypt • El Salvador • Finland • France • Germany • Greece • Guatemala • Honduras • Hong Kong • Hungary • Iceland • India • Indonesia • Ireland • Israel • Italy • Jamaica • Japan • Jordan • Korea • Kuwait • Lebanon • Malaysia • Mexico • Netherlands • New Zealand • Norway • Pakistan • Peru • Philippines • Poland • Portugal • Puerto Rico • Qatar • Romania • Russia-CIS • Saudi Arabia • Singapore • Slovakia • Slovenia • South Africa, Republic • Spain • Sweden • Switzerland • Taiwan • Thailand • Turkey • United Arab Emirates • United Kingdom • United States • Uruguay • Venezuela • Yugoslavia

Allen-Bradley Headquarters, 1201 South Second Street, Milwaukee, WI 53204 USA, Tel: (1) 414 382-2000 Fax: (1) 414 382-4444