

**Selection Criteria**

Selection Flowchart .....5-2  
 Selection Tips .....5-3  
 Selection Navigator .....5-4  
 Technology Overview .....5-8

**Safety Relays**

**Overview**

Overview .....5-12  
 Selection Guidelines .....5-13  
 Make the Right Choice .....5-13

**Single-Function Safety Relays**

MSR9T .....5-14  
 MSR30RT/RTP .....5-16  
 MSR33RT/RTP .....5-18  
 MSR41 .....5-20  
 MSR117T .....5-22  
 MSR126R/T .....5-24  
 MSR127RP/TP .....5-26  
 MSR131RTP .....5-28  
 MSR142RTP .....5-30  
 MSR144RTP .....5-32

**With Delayed Outputs**

CU4 .....5-34  
 MSR38D/DP .....5-36  
 MSR138DP .....5-38  
 MSR178DP .....5-40

**Specialty Safety Relays**

**Two-Hand**

MSR35H/HP .....5-44  
 MSR125H/HP .....5-46

**Muting Light Curtain**

MSR22LM .....5-48  
 MSR42 .....5-52

**Stop Motion Monitors**

CU2 .....5-56  
 CU2 Sensor Details .....5-58

**Speed Monitors**

MSR57P .....5-60

**Back EMF Monitors**

CU3 .....5-64

**Mat Controllers**

MSR23M .....5-66  
 MatGuard™ Controllers .....5-68  
 MatGuard™ Mat Manager .....5-70

**Safedge™ Controllers**

MSR245P .....5-72

**Sipha Control Units**

MSR245P .....5-74

**Expansion Relays**

MSR45E .....5-76  
**With Delayed Outputs**

MSR132E .....5-78

**Modular Safety Relays (200 Series)**

Input and Output Module Selection .....5-80  
 MSR210P .....5-82  
 MSR211P .....5-84  
 MSR220P .....5-86  
 MSR221P .....5-88  
 MSR230P .....5-90  
 MSR238P .....5-92  
 MSR240P .....5-94  
 MSR241P .....5-96  
 MSR245P .....5-98

**Configurable Safety Relays (300 Series)**

Input and Output Module Selection .....5-100  
 MSR310P .....5-102  
 MSR312P .....5-104  
 MSR320P .....5-106  
 MSR329P .....5-108  
 MSR330P .....5-110  
 MSR338DP .....5-112

**Accessories .....5-114**

**Note:**

- E = Expander
- D = Delayed
- H = Two-Hand Control
- P = Removable Terminals
- T = Automatic Reset
- R = Manual Reset
- M = Safety Mat

‡ Information for this product line is available on the Safety Products Catalog website: [www.ab.com/catalogs](http://www.ab.com/catalogs).

**Programmable Safety Solutions**

**Overview**

Programmable Safety Solutions .....5-116  
 Rockwell Automation Safety PLCs .....5-116  
 Safety Logic Selection Flowchart .....5-117

**SmartGuard™ 600 Controller**

SmartGuard™ 600 Controller .....5-119  
 RSNetWorx™ for DeviceNet™ Software .....5-121  
 Guard I/O™ Modules .....5-122

**GuardPLC™ Safety Control Systems**

GuardPLC Safety Control Systems .....5-123  
 GuardPLC 1600 Controller .....5-125  
 GuardPLC 1800 Controller .....5-127  
 GuardPLC 1200 Controller .....Web‡  
 GuardPLC 2000 Safety System .....Web‡  
 Distributed Safety I/O for GuardPLC Ethernet .....5-129  
 DeviceNet™ Safety Scanner .....Web‡  
 RSLogix Guard Plus! Programming Software .....5-131  
 GuardPLC™ Handheld Terminal .....5-132

**GuardLogix® Integrated Safety System**

GuardLogix® Integrated Safety System Overview .....5-133  
 GuardLogix Controllers .....5-133  
 Software .....5-135

**Guard I/O™ Modules**

Guard I/O™ Modules Overview .....5-136  
 CompactBlock™ Guard I/O™ .....5-138  
 ArmorBlock® Guard I/O™ .....5-141

Logic  
Selection Flowchart

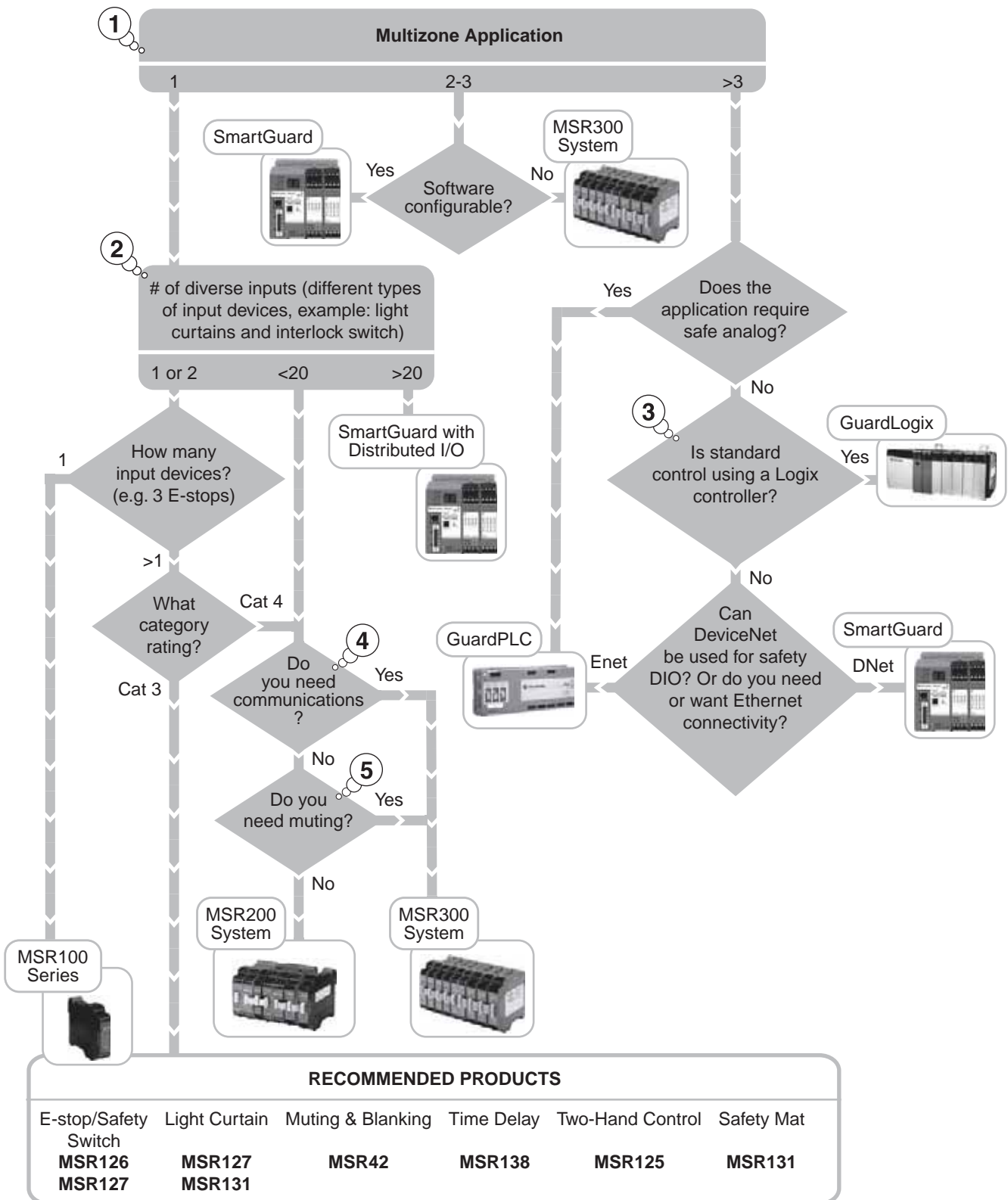

5-Selection  
Criteria

## 1 Is This a Multizone Application?

In order to comply with safety standards and remain productive, machine builders have begun building functional safety features into machines using what has been termed the “Zone Concept.” The Zone Concept increases both safety and productivity by allowing a portion of the production line to slow or stop while the rest of the line remains active. The safety hazard, whether a minor malfunction of line equipment or an obstruction, can be removed or corrected without taking the entire line down, eliminating lengthy production shut downs and worker downtime. When the hazard is cleared, the line can quickly return to normal operation. Single function and/or expandable relays systems are suited only for single-zone control, while multizone control for 2...3 zones is best served through a configurable system such as MSR300 relays or a SmartGuard packaged controller. Any applications involving control of more than three zones (and therefore more complex logic) is better suited for a programmable safety controller—SmartGuard, GuardPLC or GuardLogix.

## 2 Diverse Inputs—Number and Type

For single- and multizone applications ( $\leq 3$  zones), the number and type of inputs (e.g. interlock switches, safety mats, light curtains) will dictate the use of either safety relays (MSR100, MSR200 and MSR300) or a small packaged safety controller such as SmartGuard. For 1...2 inputs, dedicated standalone relays (MSR100) are a simple and cost effective solution, but for applications involving a high number of input devices, the hard wiring associated with individual relays can be restrictive. Therefore, in applications requiring a moderate input device count (20 or less), an expandable relay system with modular design and plug-in connections (MSR200, MSR300) is an ideal solution. In any case with safety relays, the types of input devices used will dictate the relay modules that must be selected; thus relay selection for a wide range of input devices can be complex. Applications requiring greater than 20 diverse inputs and a degree of complex logic lend themselves to the SmartGuard Controller in combination with Distributed I/O. Larger installations—those with a high number and wide variety of input device types—are best served with a safety PLC system as their programmable nature allows safety applications to be solved in software rather than hard-wiring large, cascaded relay systems.

## 3 Is Standard Control Using a Logix Controller?

A safety control system can be a dedicated (safety only) system or integrated, where standard and safety control are combined to maximize the re-use of components and tools.

GuardLogix brings together the benefits of a Logix platform—common programming environment, common networks, and common control engine—with integrated safety control in an easy-to-use environment while providing Safety Integrity Level (SIL) 3 control. By partnering with the Logix5000™ processor, GuardLogix users can benefit from common programming software, controller and I/O to help reduce development time and application cost.

GuardPLC and SmartGuard are the recommended platforms for applications requiring safety to be physically separated from standard control.

## 4 Do You Need Communications?

On-board communications allow the relay to deliver output and error status over an RS232/RS485 or fieldbus network (such as DeviceNet) to an HMI or other device. While the MSR200 series of modular safety relays does offer communications compatibility, it is not the most economical solution—MSR300 configurable safety relays are the best choice for applications requiring communications. Programmable safety controllers offer network connectivity and a high level of diagnostics, with SmartGuard and GuardPLC having DeviceNet and Ethernet capabilities, respectively.

## 5 Do You Need Muting?

Sometimes the process requires that the machine stop when personnel enters the area, yet remains running when automatically-fed material enters or exits—this is a situation where a muting function is necessary. Muting requires the combination of a light curtain, two or four muting sensors and a control unit to process the signals and determine if and when to activate the muting function. Muting sensors are mounted in front of and behind the light curtain and only a specific sequence of sensor outputs will initiate the muting function. For example, when the two sensors in front of the light curtain change state within a predetermined timeframe, the light curtain is “muted” and will not send a stop signal to the machine as the material enters. The MSR300 modular safety monitoring relay offering includes a module specifically designed to control the muting function in applications that do not require a specific sequence or timing requirement. Muting of the MSR42 can be conveniently set up using configuration software. If sequence and timing is required, then the MSR22LM may be better suited for your application.

# Logic

## Safety Relay Overview

### Safety Relay Selection Navigator

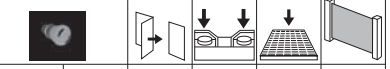
Relay Model	Cat. per EN 954-1								Immediate Outputs					Delayed Outputs					
		1 NC	2 NC	1 NC & 1 NO	THC	SM	LC/SG	SE	Safety		Auxiliary			Safety			Auxiliary		
		EM NO	SS NO	EM NC	SS NC	SS NO	EM NO	EM NC	SS NO	EM NC	SS NC	SS NO							
<b>Single Function Safety Relays</b>																			
MSR9T	3	—	—	1	—	—	—	—	2	—	1	—	—	—	—	—	—	—	—
MSR30RT/RTP	4	1	1	—	—	—	—	—	—	2	—	—	1	—	—	—	—	—	—
MSR33RT/RTP	4	—	—	1	—	—	—	—	—	2	—	—	1	—	—	—	—	—	—
MSR41	4	—	—	—	—	—	1	—	—	2	—	2	—	—	—	—	—	—	—
MSR117	4	1	—	—	—	—	—	—	3	—	1	—	—	—	—	—	—	—	—
MSR126R/T	4	1	1	—	—	—	1	—	2	—	—	—	—	—	—	—	—	—	—
MSR127RP/TP	4	1	1	—	—	—	1	—	3	—	1	—	—	—	—	—	—	—	—
MSR131RP/TP	4	1	1	—	—	1	1	—	3	—	2	2	—	—	—	—	—	—	—
MSR142RTP	4	1	1	—	—	1	1	—	7	—	4	2	—	—	—	—	—	—	—
MSR144RTP	4	1	1	—	—	1	1	—	2	—	2	2	—	—	—	—	—	—	—
<b>Delayed Outputs</b>																			
CU4	3	—	—	—	—	—	—	—	—	—	—	—	—	2	1	—	—	—	—
MSR38D/DP	4	1	1	—	—	1	—	—	—	—	—	—	1	—	—	2	—	—	—
MSR138DP	4/3	1	1	—	—	—	1	—	2	—	—	—	—	3	—	—	—	—	—
MSR138.1DP	4/3	1	1	—	—	—	1	—	2	—	—	—	—	2	1	—	—	—	—
MSR178DP	4	1	1	—	1	—	1	—	—	—	—	—	—	3	—	—	2	—	—
<b>Specialty Safety Relays</b>																			
<b>Two-Hand Control</b>																			
MSR35H/HP	4	—	—	2	1	—	—	—	—	2	—	—	1	—	—	—	—	—	—
MSR125H/HP	4	—	—	2	1	—	—	—	2	—	—	—	—	—	—	—	—	—	—
<b>Muting Light Curtain</b>																			
MSR22LM	4	—	—	—	—	—	3	—	2	—	1	2	—	—	—	—	—	—	—
MSR42	4	—	1	—	—	—	3	—	—	2	—	2	—	—	—	—	—	—	—
<b>Stop Motion Monitors</b>																			
CU2	1	—	—	1	—	—	—	—	—	—	—	—	—	2	—	1	—	—	—
<b>Speed Monitors</b>																			
MSR57P	4	1	1	1	—	1	1	—	—	6	—	—	—	—	—	—	—	—	—
<b>Back EMF Monitors</b>																			
CU3	1	—	—	—	—	—	—	—	2	—	1	—	—	—	—	—	—	—	—
<b>Mat Controllers</b>																			
MSR23	3	—	—	—	—	1	—	—	2	—	1	—	—	—	—	—	—	—	—
440F-C4000P	3	—	—	—	—	1	—	—	2	—	1	—	—	—	—	—	—	—	—
440F-C4000S	3	—	—	—	—	1	—	—	2	—	1	—	—	—	—	—	—	—	—
<b>Mat Manager</b>																			
C280**	3	—	—	—	—	8*	—	—	6*	—	1	—	—	—	—	—	—	—	—
<b>Safedge™ Controllers</b>																			
251D	3	—	—	—	—	—	—	1‡	2	—	1	—	—	—	—	—	—	—	—
252D	3	—	—	—	—	—	—	1‡	1	—	1	—	—	—	—	—	—	—	—
C251P	3	—	—	—	—	—	—	1‡	2	—	1	—	—	—	—	—	—	—	—
<b>Sipha Controllers</b>																			
Sipha 1	3	—	—	1	—	—	—	—	1	—	—	1	—	—	—	—	—	—	—
Sipha 2	3	—	—	6	—	—	—	—	2	—	1	—	—	—	—	—	—	—	—
Sipha 6	4	—	—	6	—	—	—	—	2	—	1	—	—	1	—	—	—	—	—

**Note:** THC = Two-hand Control, SM = Safety Mat, LC = Light Curtain, SG = SensaGuard, SE = Safedge, EM = Electromechanical, SS = Solid State, and • = included

\* Up to eight mats can be monitored.

\* Up to six mats can be monitored.

‡ Can support more than one edge in series or parallel.

Operating Voltage				Reset*		Output Switching Current, A		Housing Width (mm)	Removable Terminals	Additional Information	Relay Model
24 DC	24 AC	115 AC	230 AC	Auto./Man.	Mon. Man.	250V AC	24V DC				
•	•	•	•	•	—	4	3	45.5	—	5-14	MSR9T
•	—	—	—	•	•	—	2	22.5	•	5-16	MSR30RT/RTP
•	—	—	—	•	•	—	2	22.5	•	5-18	MSR33RT/RTP
•	—	—	—	•	—	—	4	22.5	•	5-22	MSR41
•	•	—	—	•	—	5	3	22.5	—	5-22	MSR117
•	•	•	•	•	•	6	3	22.5	—	5-24	MSR126R/T
•	•	•	•	•	•	5	3	22.5	•	5-26	MSR127RP/TP
•	•	•	•	•	•	6	3	45.0	•	5-28	MSR131RP/TP
—	•	•	•	•	•	6	3	67.5	•	5-30	MSR142RTP
•	—	—	—	•	•	5	3	45.0	•	5-32	MSR144RTP
•	•	—	—	•	—	5	3	22.5	—	5-34	CU4
•	—	—	—	•	•	—	2	22.5	•	5-36	MSR38D/DP
•	•	•	•	•	•	6	3	45.0	•	5-38	MSR138DP
•	•	•	•	•	•	6	3	45.0	•	5-38	MSR138.1DP
•	•	•	•	•	—	4	2	35.0	•	5-40	MSR178DP
•	—	—	—	—	—	—	2	22.5	•	5-44	MSR35H/HP
•	—	•	•	—	—	6	3	22.5	•	5-46	MSR125H/HP
•	—	—	—	—	•	3	3	45.0	•	5-48	MSR22LM
•	—	—	—	•	•	—	4	22.5	•	5-48	MSR42
•	•	•	•	•	—	4	3	45	—	5-56	CU2
•	—	—	—	•	•	—	2	67.5	•	5-60	MSR57P
•	•	•	•	•	—	4	3	45	—	5-64	CU3
•	•	•	—	•	•	3	3	22.5 & 45.0	•	5-66	MSR23M
•	•	•	•	•	•	4	2	210	—	5-66	440F-C4000P
•	•	•	•	•	•	4	2	210	—	5-66	440F-C4000S
•	•	•	•	•	•	4	2	210	—	5-70	C280
•	•	•	•	•	—	2	1	45	—	5-72	251D
•	•	—	—	•	—	2	1	22.5	—	5-72	252D
•	•	•	•	•	—	2	1	130	—	5-72	C251P
•	•	—	—	•	—	4	2	22.5	—	5-74	Sipha 1
•	•	•	•	•	—	4	2	45	—	5-74	Sipha 2
•	•	•	•	•	—	4	2	90	—	5-74	Sipha 6

Note: Auto./Man. = Automatic/Manual and Mon. Man. = Monitored Manual, and • = included

# Logic

## Safety Relay Overview

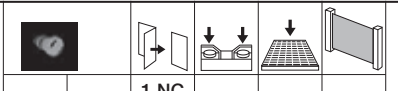
Relay Model	Cat. per EN 954-1								Immediate Outputs					Delayed Outputs					
		1 NC	2 NC	1 NC & 1 NO	THC	SM	LC/SG	SE	Safety		Auxiliary			Safety			Auxiliary		
									EM NO	SS NO	EM NC	SS NC	SS NO	EM NO	EM NC	SS NO	EM NC	SS NC	SS NO
<b>Expansion Relays</b>																			
MSR45E	4	—	—	—	—	—	—	—	2	—	—	—	—	—	—	—	—	—	—
MSR132E/EP	4	1	1	—	—	—	—	—	4	—	2	—	—	—	—	—	—	—	—
<b>Delayed Outputs</b>																			
MSR132ED/EDP	3	1	1	—	—	—	—	—	—	—	—	—	—	4	—	—	2	—	—
<b>Modular Safety Relays (Series 200)</b>																			
MSR210P	4	2	2	2	—	2	—	—	2	—	1	—	2	—	—	—	—	—	—
MSR211P	4	2	2	—	—	—	2	—	2	—	1	—	2	—	—	—	—	—	—
MSR220P	4	2	2	2	—	2	—	—	—	—	—	—	—	—	—	—	—	—	—
MSR221P	4	2	2	—	—	—	2	—	—	—	—	—	—	—	—	—	—	—	—
MSR230P	4	—	—	—	—	—	—	—	4	—	—	—	—	—	—	—	—	—	—
MSR238P	3	—	—	—	—	—	—	—	—	—	—	—	—	2	—	—	1	—	—
MSR240P	—	—	—	—	—	—	—	—	—	—	—	—	—	—	—	—	—	—	—
MSR241P	—	—	—	—	—	—	—	—	—	—	—	—	2	—	—	—	—	—	—
MSR245P	—	—	—	—	—	—	—	—	—	—	—	—	—	—	—	—	—	—	—
<b>Configurable Safety Relays (Series 300)</b>																			
MSR310P	4	—	—	—	—	—	—	—	—	—	—	—	3	—	—	—	—	—	—
MSR312P	4	—	—	—	—	—	—	—	—	—	—	—	4	—	—	—	—	—	—
MSR320P	4	2	2	2	1	2	2	—	—	—	—	—	2	—	—	—	—	—	—
MSR329P	4	—	—	—	—	—	—	—	—	—	—	—	4	—	—	—	—	—	—
MSR330P	4	—	—	—	—	—	—	—	3	—	1	—	—	—	—	—	—	—	—
MSR338DP	3	—	—	—	—	—	—	—	—	—	—	—	—	3	—	—	1	—	—

Note: THC= Two-hand Control, SM = Safety Mat, LC = Light Curtain, SG = SensaGuard, SE = Safedge, EM = Electromechanical, and SS = Solid State

Operating Voltage				Reset*		Output Switching Current, A		Housing Width (mm)	Removable Terminals	Additional Information	Relay Model
24 DC	24 AC	115 AC	230 AC	Auto./Man.	Mon. Man.	250V AC	24V DC				
—	—	—	—	—	—	3	6	22.5	•	5-78	MSR45E
•	•	—	—	—	—	6	3	22.5	•	5-78	MSR132E/EP
•	—	—	—	—	—	6	3	22.5	•	5-78	MSR132ED/EDP
•	—	—	—	•	•	3	2.5	45.0	•	5-82	MSR210P
•	—	—	—	•	•	3	2.5	45.0	•	5-84	MSR211P
•	—	—	—	—	—	—	—	17.5	•	5-86	MSR220P
•	—	—	—	—	—	—	—	17.5	•	5-88	MSR221P
•	—	—	—	—	—	3	2.5	22.5	•	5-90	MSR230P
•	—	—	—	—	—	5	3	22.5	•	5-92	MSR238P
•	—	—	—	—	—	—	—	17.5	•	5-94	MSR240P
•	—	—	—	—	—	—	2	45	•	5-96	MSR241P
•	—	—	—	—	—	—	—	144	•	5-98	MSR245P
•	—	—	—	•	•	—	—	35	•	5-102	MSR310P
•	—	—	—	•	•	—	—	35	•	5-104	MSR312P
•	—	—	—	—	—	—	50 mA	17.5	•	5-106	MSR320P
•	—	—	—	—	—	—	30...200 mA	17.5	•	5-108	MSR329P
•	—	—	—	—	—	6	3	22.5	•	5-110	MSR330P
•	—	—	—	—	—	5	3	22.5	•	5-112	MSR338DP

Note: Auto./Man. = Automatic/Manual and Mon. Man. = Monitored Manual, and • = included

## MSR100 Single Function Safety Relays



### Features/Benefits

A simple and cost-effective solution for a wide variety of applications, MSR100 single function safety relays support a wide variety of input devices and output configurations. Ideal for relatively small safety applications and single zone control, MSR100 relays are designed in a compact package with removable terminal for ease of installation and maintenance. These relays are also available in electromechanical versions, or solid-state models for applications involving high cycle rates.

### Applications

- Wide range of general purpose applications
- Automotive
- Packaging
- Food and beverage
- Semiconductor
- Material handling
- OEM machines

### Common Misapplications

- Complex safety solutions
- Applications requiring a high level of diagnostics
- Driving high current loads
- Electromechanical relays used for high cycle rates

## MSR200 Modular Safety Relays



### Features/Benefits

Using plug-and-play digital I/O expansion modules, the MSR200 expandable modular relay system supports up to 22 diverse inputs (mats, light curtains, switches, etc.) to allow safety control of larger, more complex manufacturing equipment with a single relay system. The MSR200 family's microprocessor-based design offers enhanced diagnostic and communication functionality over multiple protocols. It also allows the relay to deliver output and error status over a fieldbus network to an HMI. Simple plug-in connectivity between modules provides simple system expansion with reduced wiring. Offering SIL3, delayed output support and an optional dedicated display module, the MSR200 system provides substantial cabinet space savings over dedicated single-function relays.

### Applications

- Wide range of general purpose applications
- Automotive
- Packaging
- Food and beverage
- Semiconductor
- Material handling
- PLC controlled applications
- Medium size machines

### Common Misapplications

- Dedicated input connections for input devices
- Not economical when communication is needed (MSR300 recommended)

## MSR300 Configurable Safety Relays



### Features/Benefits

The MSR300 family of expandable modular safety relays handles larger, more complicated safety systems by allowing connection of multiple input modules to a single base unit. It offers a logic configuration with multiple inputs and the control of multiple independent outputs. The system supports up to 20 diverse inputs and can control up to 3 zones, performing simple function block logic configurations through rotary switch settings as opposed to software configuration. Modules can be mixed and matched to work with various input device types, reducing the need for multiple single-purpose relays, simplifying setup, wiring, maintenance and saving valuable panel space. The MSR300's diagnostic capabilities over multiple protocols provide input, output and error status. Offering SIL3, two-hand control support and monitoring through HMI, the MSR300 is easily customized and expanded thanks to plug-in connections that reduce wiring for the addition of inputs and outputs.

### Applications

- Wide range of general purpose applications
- Automotive
- Packaging
- Food and beverage
- Semiconductor
- Material handling
- Wide variety of input types
- Reduced inventory

### Common Misapplications

- Single zone applications with no communications requirements

## SmartGuard™ 600



### Features/Benefits

The SmartGuard 600 controller is designed for SIL3 applications that require some complex logic. It is a “packaged safety controller” that includes the CPU, 16 Safety Inputs and 8 Safety Outputs and an embedded DeviceNet communications port. Using the DeviceNet communications port, the SmartGuard 600 controller can control additional safety I/O modules including the 1791DS CompactBlock Guard I/O and 1732DS ArmorBlock Guard I/O, as well as 1734 POINT Guard I/O modules via a 1734-PDN module. In addition, the SmartGuard controller can also communicate with standard PLCs and HMIs on DeviceNet or EtherNet/IP networks. SmartGuard 600 systems are programmed using RSNetworkx software.

### Applications

- Wide range of general purpose applications
- Automotive
- Packaging
- Food and beverage
- Semiconductor
- Material handling

### Common Misapplications

- Simple applications (MSR300 recommended)

## Guard I/O™



### Features/Benefits

Guard I/O is the name for the Rockwell Automation family of Safety I/O modules that communicate via CIP Safety on EtherNet/IP and DeviceNet networks. CompactBlock Guard I/O modules on EtherNet/IP and DeviceNet networks are available in IP20 (in-cabinet) form-factor. ArmorBlock Guard I/O modules on DeviceNet networks are available in IP67 (on-machine) form-factors. POINT Guard I/O modules provide EtherNet/IP and DeviceNet connectivity in a maximum density in-cabinet I/O solution.

### Applications

- Wide range of general purpose applications
- Automotive
- Packaging
- Food and beverage
- Semiconductor
- Material handling

### Common Misapplications

- Simple applications (MSR300 recommended)

## GuardPLC™



### Features/Benefits

GuardPLC refers to a family of SIL3 safety controllers that are programmed with the RSLogix Guard software package. Like the SmartGuard 600, the GuardPLC 1600 and GuardPLC 1800 Safety PLCs are “packaged safety controllers” with a CPU, safety I/O and embedded communication networks. In the case of the GuardPLC 1600 and 1800 the embedded communication network is Ethernet for communication to GuardPLC Safety I/O modules as well as EtherNet/IP for communications to standard controllers and HMIs. The GuardPLC 1600 includes 20 safety inputs and 8 safety outputs. The GuardPLC 1800 includes 24 safety inputs, 8 safety outputs, 8 analog safety inputs and 2 safety rated high speed counters.

### Applications

- Wide range of general purpose applications
- Automotive
- Packaging
- Food and beverage
- Semiconductor
- Material handling

### Common Misapplications

- Simple applications with low I/O counts

## GuardLogix®



### Features/Benefits

The GuardLogix system is a SIL3 Logix5000™ controller that in addition to running all standard control functions like sequential, motion, etc., also has the ability to run a Safety Task and control safety DIO. This enables both safety and standard applications to run simultaneously in a single application project. This significantly reduces integration, spares and training and improves the flow of data to HMI and information systems. A GuardLogix controller communicates to Safety I/O via a standard communication modules. It is programmed with RSLogix 5000, just like a Logix5000 processor.

### Applications

- Wide range of general purpose applications
- Automotive
- Packaging
- Food and beverage
- Semiconductor
- Material handling

### Common Misapplications

- Simple applications with low I/O counts

## Logic

# Safety Relay Overview

## Why Use a Minotaur?

Control units provide functions such as time delays, motion sensing and two hand control supervision.

The functional requirements for monitoring safety relay units, such as the Guardmaster Minotaur range, will depend on their use in the system.

Their basic tasks are:

1. To detect faults on safety-related electrical control circuits, e.g. faults in sensors, wiring, contactors, etc.
2. To provide an ensured switching action, e.g. to act as an intermediate relay to amplify a signal or distribute it to multiple devices.
3. To provide a manual reset facility. They achieve their function by using internal redundancy (e.g. duplication) and monitoring.

### With Safety Relay

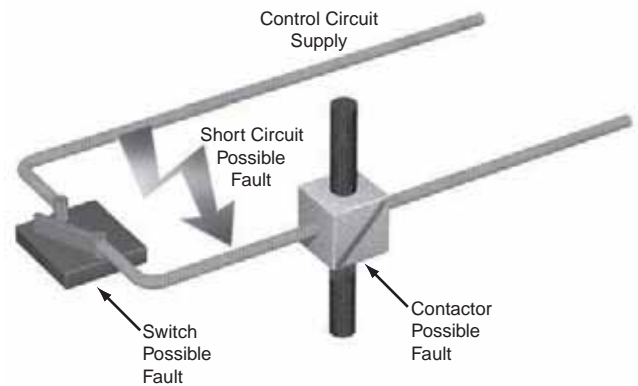

### With Safety Relay

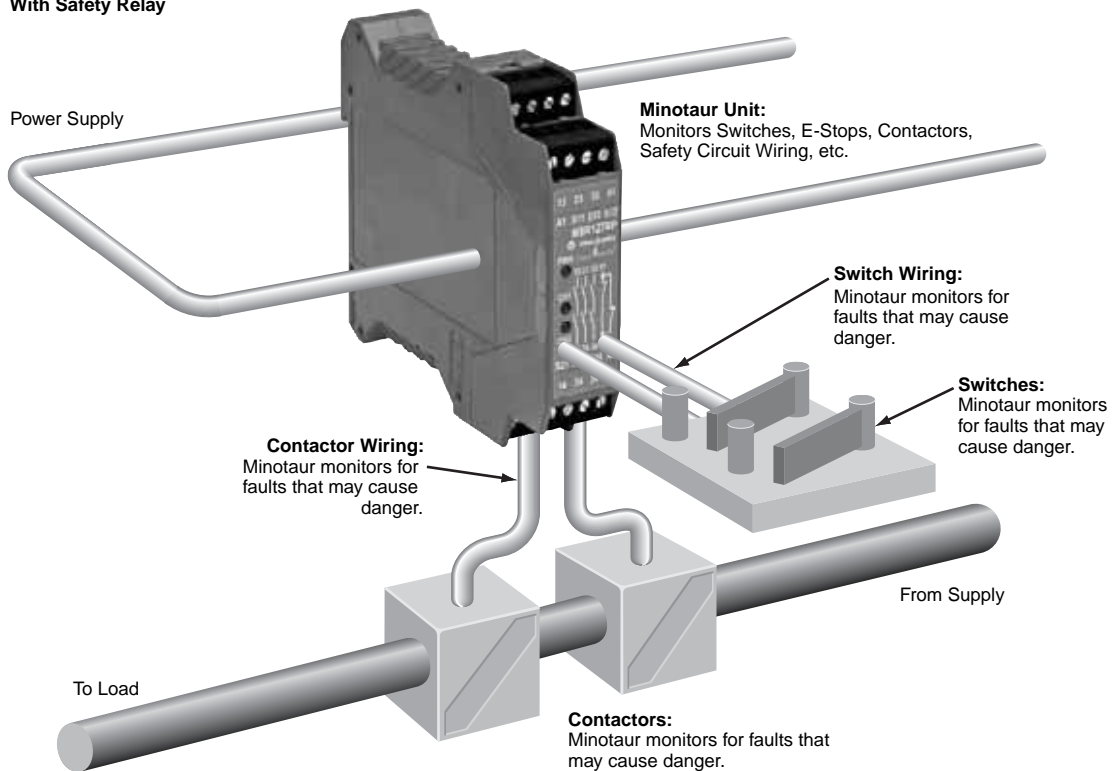

### Applications

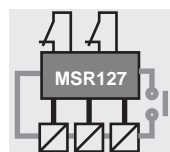

- Contactor monitoring circuit
- Contactor switching circuit
- Supply inclusive of switching circuit
- ☐ Contactor
- Monitored by Minotaur

### Selection Guidelines

There are four safety system architectures available from Rockwell Automation. They are as follows:

**1. Component systems:** At the lowest level, a safety function can be accomplished with an actuating device and a control device. For example, an e-stop button that opens up the coil of a safety control relay performs a simple safety function. Component system architectures are typically used in low risk applications.

**2. Dedicated safety monitoring relay systems:** Dedicated safety relays are used for specific applications. These systems utilize packaged control modules that are designed to interface to common safety devices such as e-stops, safety gates, light curtains, and safety mats. Some dedicated relays provide special functions like timing, two-hand control, muting, and presence sensing device initiation. Since there are many different types of input devices and functions, there are many different types of dedicated safety monitoring relays. Dedicated safety monitoring relays have the ability to provide basic diagnostics in the form of LEDs on their front panels and auxiliary contacts that may be connected to a PLC or indicator lamp. Dedicated safety relays system architectures are typically used in medium to high-risk applications.

**3. Expandable safety monitoring relay systems (MSR200):** It provides the unique ability to easily add input and output modules to a "basic" safety relay module. Since the modular system is microprocessor based, it also has the ability to provide enhanced diagnostics over a communication connection. For instance, the I/O and error status can be communicated over a field bus network. Being a relatively new architecture, it currently accepts inputs from common types of safety devices: e-stops, safety gates, light curtains and safety mats. Modular safety relay system architectures are typically used in medium- to high-risk applications.

**4. Configurable safety monitoring relay systems (MSR300):** The MSR300 family of expandable modular safety relays handles larger, more complicated safety systems by allowing connection of multiple input modules to a single base unit. It offers the ability for a logic configuration with multiple inputs and the control of multiple independent outputs. The system can control up to three independent groups of outputs and perform simple function block logic configurations through rotary switch settings—no software needed. Mix and match modules to work with various input device types, reduces the need for multiple single-purpose relays, simplifies setup, wiring, maintenance and saves valuable panel space. The MSR300s diagnostic capabilities and communication functionality also reduces maintenance time by providing input, output and error status.

**5. Safety PLC systems:** Safety PLCs bring programmability, high I/O counts, distributed control and a high level of communications to safety architectures. They also bring some special functions not previously available in dedicated systems: high speed counters and analog signals. Safety PLC architectures are often applied in a variety of complex, high-risk applications.

### Making the Right Choice

Begin the selection process by evaluating the needs of your application. The *Quick Guide* below can be used to direct you towards the best solution. Some of the guidelines will clearly point you to one type of architecture or another. Some will require further analysis before making a final decision. Due to the diverse nature of machine guarding, it is possible to create a hybrid system or a combination of architectures to provide adequate safeguarding of a particular machine or manufacturing system.

#### Quick Guide

Characteristics	Architecture
<b>Application Complexity</b>	
Low	Dedicated Relays
Medium	Dedicated or Expandable Relays
High	Safety PLCs
<b>Communication</b>	
Status	Expandable Relays
Control	Safety PLCs
<b>Diagnostics</b>	
Low	Dedicated Relays
Medium	Expandable Relays
High	Safety PLCs
<b>Expandability</b>	
Low	Dedicated Relays
Medium	Expandable Relays
High	Safety PLCs
<b>Input Types</b>	
Special	Dedicated Relays or Safety PLCs
Common	Dedicated or Expandable Relays
<b>I/O Count</b>	
Low	Dedicated Relays
Medium	Expandable Relays
High	Safety PLCs
<b>I/O Location</b>	
Contained	Dedicated or Expandable Relays
Spread Out	Safety PLCs
<b>Sequential Shutdown</b>	
None	Dedicated or Expandable Relays
Yes	Safety PLCs
<b>Zone Control</b>	
Few	Dedicated or Expandable Relays
Many	Safety PLCs

Logic  
**Single-Function Safety Relays**  
**MSR9T**



**Description**

The MSR9T has one normally closed and one normally open dual-channel input for use with gate interlocks and emergency stop buttons in higher risk applications. The MSR9T is typically used for gate interlocks incorporating the diversity of one positive opening and one non-positive opening interlock.

The MSR9T has output monitoring that can accommodate an automatic/manual reset. Automatic/manual reset can use a jumper or can be used to check operation of the contacts.

The MSR9T has two normally open safety outputs and one normally closed auxiliary output. The safety outputs have independent and redundant internal contacts to support the safety function. The auxiliary contact is a nonsafety output intended to provide an external signal about the status of the safety outputs.

**Features**

- Category 3 per EN 954-1
- Stop category 0
- One N.C. and one N.O. dual channel input
- Two N.O. safety outputs
- One N.C. auxiliary output
- Automatic reset
- 45 mm wide housing

**LED Indicators**

Green	Power On
Green	Output On

**Specifications**

<b>Safety Ratings</b>	
Standards	EN 954-1, ISO13849-1, IEC/EN 60204-1, IEC 60947-5-1, ANSI B11.19, AS4024.1
Safety Classification	Cat. 3 per EN 954-1 (ISO 13849-1)
Certifications	CE Marked for all applicable directives, cULus, and c-Tick
<b>Power Supply</b>	
Input Power Entry	24V AC/DC, 115/230V AC, 50/60 Hz
Power Consumption	<4V A
<b>Inputs</b>	
Safety Inputs	1 N.C. & 1 N.O.
Input Simultaneity	0.5 seconds
Input Resistance, Max.	500 Ω
Reset	Auto./Manual
Response Time	50 ms
<b>Outputs</b>	
Safety Contacts	2 N.O.
Auxiliary Contacts	1 N.C.
Thermal Current <sub>I<sub>th</sub></sub>	4 A (nonswitching)
Rated Impulse withstand Voltage	2500V
Switching Current @ Voltage, Min.	10 mA @ 10V
Fuses, Output	5 A quick acting (external)
Electrical Life	220V AC/4A/880VA cosφ = 0.35...0.1 M 220V AC/1.7A/375VA cosφ = 0.6...0.5 M 30V DC/2A/60W = 1 M 10V DC/0.01A/0.1W = 2 M
Mechanical Life	2,000,000 operations
<b>Utilization Category</b>	
A300/AC-15	(Ue) 240V 120V (Ie) 3 A 6 A
A300/DC-13	(Ue) 24V (Ie) 3 A
<b>Environmental and Physical Characteristics</b>	
Enclosure Type Rating/ Terminal Protection	IP40 (NEMA 1), DIN 0470/ IP20, DIN 0470
Operating Temperature [C (F)]	-10...+55 ° (14...131 °)
Vibration	0.75 mm (0.30 in.) peak, 10...55 Hz
Shock	30 g, 11 ms half-sine
Mounting	35 mm DIN Rail
Weight [g (lbs)]	210 (0.46)
Conductor Size, Max.	1 x 2.5 mm <sup>2</sup> (14 AWG) stranded, 1 x 4 mm <sup>2</sup> (12 AWG) solid

\* Usable for ISO 13849-1:2006 and IEC 62061. Data is based on the following assumptions:  
 - Mission time/Proof test interval of 20 years  
 - Functional test at least once within six-month period

**Product Selection**

Inputs	Safety Outputs	Auxiliary Outputs	Terminals	Reset Type	Power Supply	Cat. No.
1 N.C. & 1 N.O.	2 N.O.	1 N.C.	Fixed	Auto./Manual	24V AC/DC	440R-F23027
					110/230V AC	440R-F23028

**Accessories**

Description	Cat. No.
500 mA Fuse—Bussmann Cat. No. ETF-500 mA	440R-A31562

**Approximate Dimensions**

Dimensions are shown in mm (in.). Dimensions are not intended to be used for installation purposes.

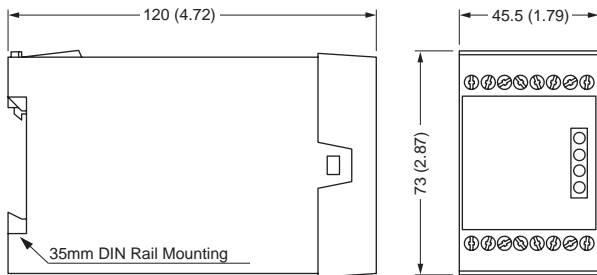

**Typical Wiring Diagrams**

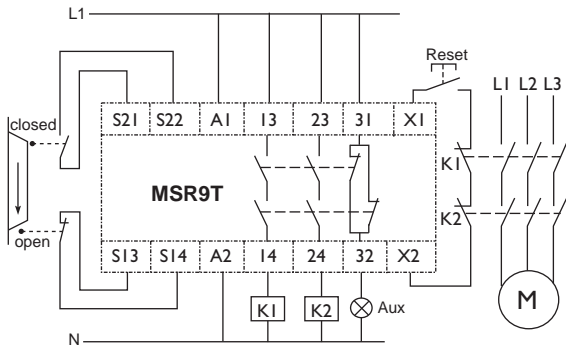

**Dual-Channel Safety Gate, Manual Reset,  
 Dual-Channel Output, Monitored Output**

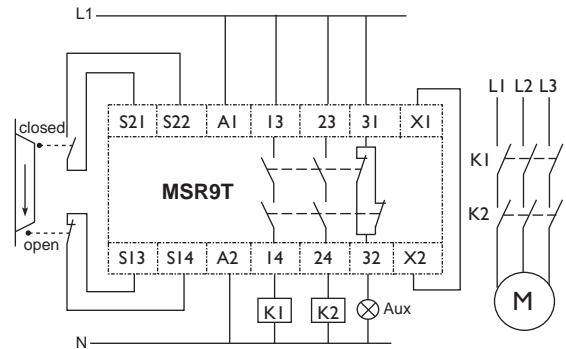

**Dual-Channel Safety Gate, Automatic Reset,  
 Dual-Channel Output, No Monitored Output**

**Application Details**

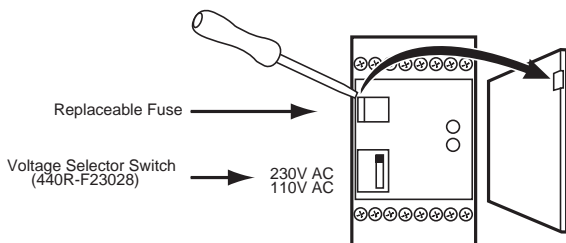

# Logic

## Single-Function Safety Relays

### MSR30RT/RTP



Housing with removable terminals shown.

#### Description

The Minotaur MSR30RT/RTP is a microprocessor based, monitoring safety relay, with safety-rated, solid-state outputs.

The versatility of the MSR30RT/RTP inputs allows it to be connected to gate interlocks, e-stop devices and four-wire safety mats. The gate interlocks and e-stops can be either single channel or dual channel normally-closed circuits.

The reset capability of the MSR30RT/RTP allows it to set up for manual or automatic start and restart.

The outputs include two normally-open safety-rated outputs that can be connected to loads up to 2 A at 24V DC. These outputs can be used to send a safety stop signal to a machine or manufacturing system.

The MSR30RT/RTP also has one solid-state normally-closed auxiliary output, which must only be used to indicate the status of the MSR30RT/ RTP.

#### Features

- Category 4 per EN954-1
- Stop Category 0
- Two solid-state safety outputs
- One solid-state auxiliary output
- One N.C., two N.C or safety mat input
- Monitored manual or automatic/manual reset

#### LED Indicators

Green	Power (Pwr)
Green	K1 Closed
Green	K2 Closed

#### Wiring Terminations

S11 & S21	Pulse train output
S12 & S22	Input contacts
A1 – S34	Reset switch
S11 – S34	Automatic reset, start-up test disabled
S21 – S34	Automatic reset, start-up test enabled
A1 – Y2	Monitoring circuit
A1 – Y41	Cross-fault monitoring disabled

#### Specifications

Safety Ratings	
Standards	EN 954-1, ISO 13849-1, IEC EN 60204-1, ANSI B11.19, AS 4024.5
Safety Classification	Cat. 4 per EN 954-1 (ISO 13849-1), SIL CL3 per EN IEC 62061, PLe per ISO 13849-1
Functional Safety Data * Note: For up-to-date information, visit <a href="http://www.ab.com/Safety/">http://www.ab.com/Safety/</a>	PFH <sub>D</sub> : < 9.2 x 10 <sup>-10</sup> MTTF <sub>d</sub> : > 631 years Suitable for performance levels Pl <sub>e</sub> (according to ISO 13849-1:2006) and for use in SIL CL3 systems (according to IEC 62061) depending on the architecture and application characteristics
Certifications	CE Marked for all applicable directives, cULus, c-Tick, and TÜV
Power Supply	
Input Power Entry	24V DC SELV
Power Consumption	3 W
Inputs	
Safety Inputs	1 N.C., 2 N.C.
Input Simultaneity	Infinite
Input Resistance, Max.	200 Ω
Reset	Auto./Manual or Monitored Manual
Power On Delay/Recovery Time	3 seconds/20 ms
Response Time	15 ms
Outputs	
Safety Contacts	2 N.O. Solid State
Auxiliary Contacts	1 N.O. Solid State
Fuses, Output	External 6 A slow blow or 10 A fast acting
Power LED Diagnostics	3 s Blink: Initialization Constant: Normal Operation 2 Blinks: Configuration change during operation 3 Blinks: Cross-fault after reset 4 Blinks: Solid-state output switch fault Continuous blinking: Internal fault 5 Blinks: Reset switch closed after reset
Utilization Category	
DC-13	2 A @ 24V DC
Environmental and Physical Characteristics	
Enclosure Type Rating/ Terminal Protection	IP40 (NEMA 1) DIN 0470/ IP20, DIN 0470
Operating Temperature [C (F)]	-5...+55 ° (23...131 °)
Vibration	10...55 Hz, 0.35 mm
Shock	10 g, 16 ms, 100 shocks
Mounting	35 mm DIN Rail
Weight [g (lbs)]	130 (0.287)
Conductor Size, Max.	0.2...2.5 mm <sup>2</sup> (24...14 AWG)

- \* Usable for ISO 13849-1:2006 and IEC 62061. Data is based on the following assumptions:  
- Mission time/Proof test interval of 20 years

**Product Selection**

Inputs	Safety Outputs	Auxiliary Outputs	Terminals	Reset Type	Power Supply	Cat. No.
1 N.C., 2 N.C.	2 N.O. Solid State	1 N.O. Solid State	Fixed	Auto./Manual or Monitored Manual	24V DC SELV	440R-N23197
			Removable		24V DC	440R-N23198

**Accessories**

Description	Cat. No.
Bag of 4, 4-Pin Screw Terminal Blocks	440R-A23209
Bag of 4, 4-Pin Spring Clamp Terminal Blocks	440R-A23228

**Approximate Dimensions**

Dimensions are shown in mm (in.). Dimensions are not intended to be used for installation purposes.

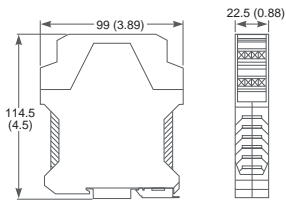

**Block Diagram**

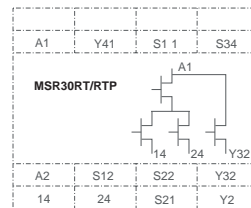

**Typical Wiring Diagrams**

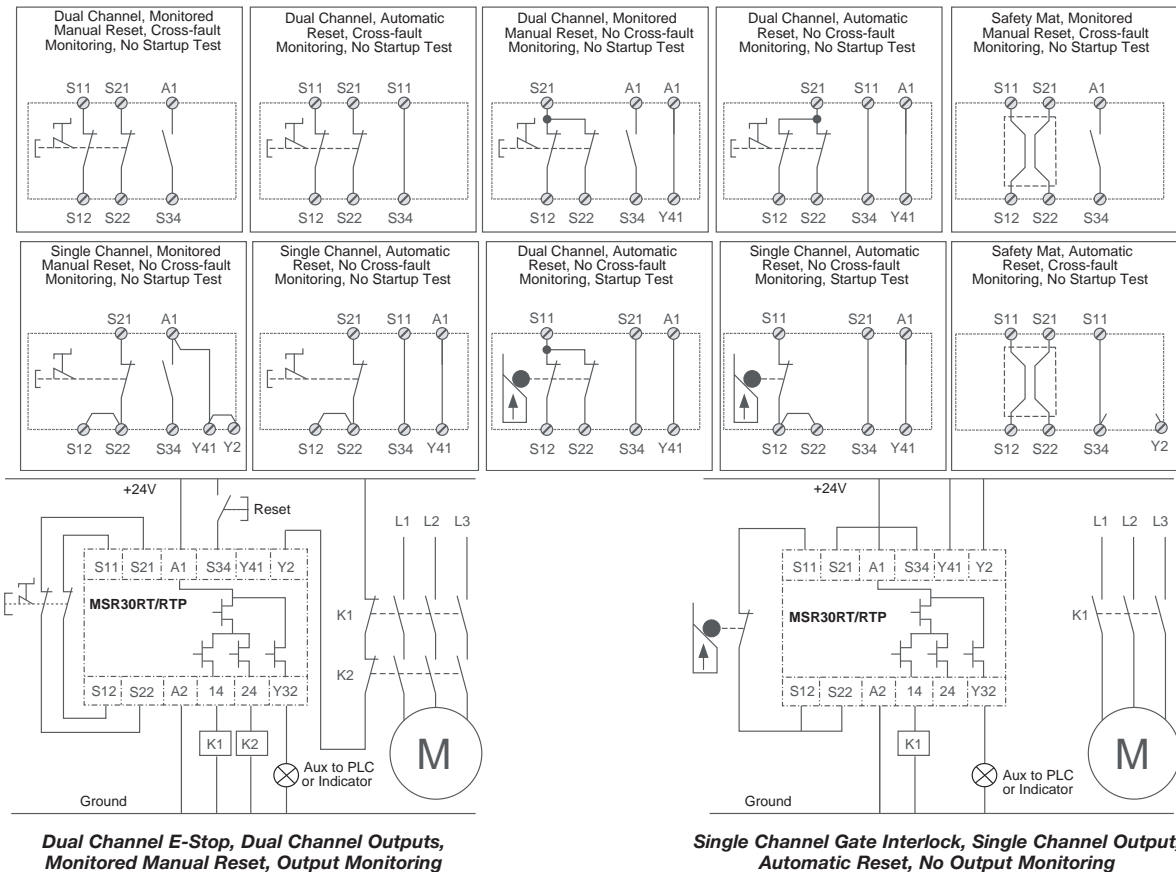

5-Safety Relays

# Single-Function Safety Relays

## MSR33RT/RTP



Housing with removable terminals shown.

### Description

The Minotaur MSR33RT/RTP is a microprocessor-based, monitoring safety relay, with safety-rated, solid-state outputs.

The MSR33RT/RTP is designed to operate with dual channel inputs where one channel is normally closed and the other is normally open. The Sipa sensors can be connected to the MSR33RT/RTP inputs.

Test pulses are used to dynamically check the input circuits. All inputs and outputs are short-circuit protected.

The reset capability of the MSR33RT/RTP allows it to set up for monitored manual or automatic reset. A start-up test can be enabled if automatic reset is used. The start-up test requires the inputs to be cycled before energizing the outputs. The reset and start-up test is determined by the connection wiring.

The outputs include two normally-open safety-rated outputs that can be connected to loads up to 2 A at 24V DC. These outputs can be used to send a safety stop signal to a machine or manufacturing system.

The MSR33 also has one solid-state, normally-open auxiliary output, which must only be used to indicate status of the MSR33RT/RTP.

### Features

- Category 4 per EN954-1
- Stop Category 0
- Two solid-state N.O. safety outputs
- One solid-state N.O. auxiliary output
- One N.O. and one N.C. input

### LED Indicators

Green	Power (Pwr)
Green	CH1 Energized
Green	CH2 Energized

### Wiring Terminations

S11 & S21	Pulse checking dynamic output
S12 & S22	Input contacts
A1 – S34	Reset switch
S11 – S34	Automatic reset, start-up test disabled
S21 – S34	Automatic reset, start-up test enabled
A1 – Y2	Monitoring circuit

### Specifications

Safety Ratings	
Standards	EN 954-1, ISO 13849-1, IEC/EN 60204-1, ANSI B11.19, AS 4024.5
Safety Classification	Cat. 4 per EN 954-1 (ISO 13849-1), SIL CL3 per EN IEC 62061, PLe per ISO 13849-1
Functional Safety Data * <b>Note:</b> For up-to-date information, visit <a href="http://www.ab.com/Safety/">http://www.ab.com/Safety/</a>	PFH <sub>D</sub> : < 9.2 x 10 <sup>-10</sup> MTTF <sub>d</sub> : > 631 years Suitable for performance levels Pl <sub>e</sub> (according to ISO 13849-1:2006) and for use in SIL CL3 systems (according to IEC 62061) depending on the architecture and application characteristics
Certifications	CE Marked for all applicable directives, cULus, c-Tick, and TÜV
Power Supply	
Input Power Entry	24V DC SELV
Power Consumption	3 W
Inputs	
Safety Inputs	1 N.C. + 1 N.O.
Input Simultaneity	Infinite
Input Resistance, Max.	200 Ω
Reset	Auto. or Monitored Manual
Power On Delay/Recovery Time	3 seconds/20 ms
Response Time	15 ms
Outputs	
Safety Contacts	2 N.O. Solid State
Auxiliary Contacts	1 N.O. Solid State
Power LED Diagnostics	3 s Blink: Initialization Constant: Normal Operation 2 Blinks: Configuration change during operation 4 Blinks: Solid state output switch fault Continuous blinking: Internal fault
Environmental and Physical Characteristics	
Enclosure Type Rating/Terminal Protection	IP40 (NEMA 1), DIN VDE 0470-1/IP20
Operating Temperature [C (F)]	-5...+55 ° (23...131 °)
Vibration	10...55 Hz, 0.35 mm
Shock	10 g, 16 ms, 100 shocks
Mounting	In panel enclosure (IP54); 35 mm DIN Rail
Weight [g (lbs)]	130 (0.287)
Conductor Size, Max.	0.2...2.5 mm <sup>2</sup> (24...14 AWG)

\* Usable for ISO 13849-1:2006 and IEC 62061. Data is based on the following assumptions:  
- Mission time/Proof test interval of 20 years

**Product Selection**

Inputs	Safety Outputs	Auxiliary Outputs	Terminals	Reset Type	Power Supply	Cat. No.
1 N.C. & 1 N.O.	2 N.O. Solid State	1 N.O. Solid State	Fixed	Auto. or Monitored Manual	24V DC SELV	440R-F23199
			Removable			440R-F23200

**Accessories**

Description	Cat. No.
Bag of 4, 4-Pin Screw Terminal Blocks	440R-A23209
Bag of 4, 4-Pin Spring Clamp Terminal Blocks	440R-A23228

**Approximate Dimensions**

Dimensions are shown in mm (in.). Dimensions are not intended to be used for installation purposes.

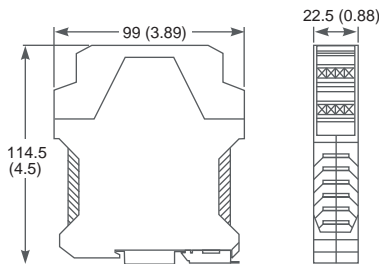

**Block Diagram**

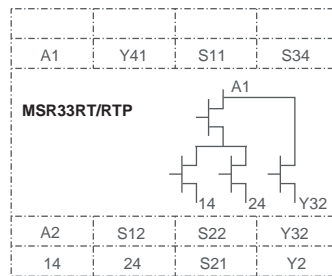

**Typical Wiring Diagrams**

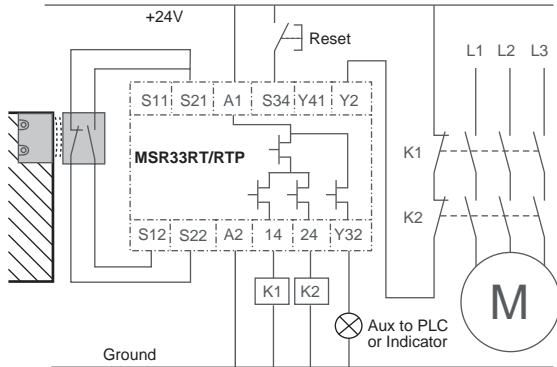

**Sipsa Sensor Inputs, Dual Channel Outputs, Monitored Manual Reset, Output Monitoring Start-up Test Disabled**

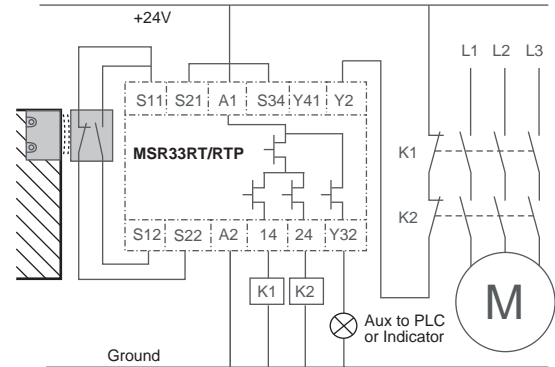

**Sipsa Sensor Inputs, Dual Channel Outputs, Automatic Reset, No Output Monitoring Start-up Test Enabled**

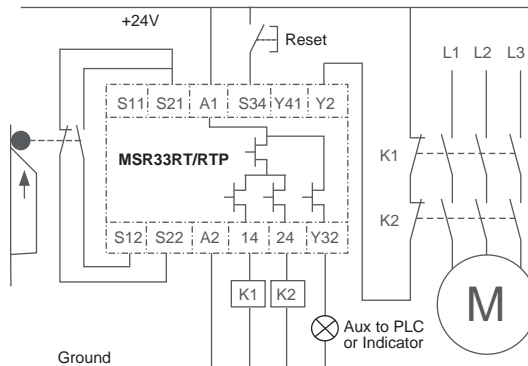

**Dual Channel Inputs, Dual Channel Outputs, Monitored Manual Reset, Output Monitoring Start-up Test Disabled**

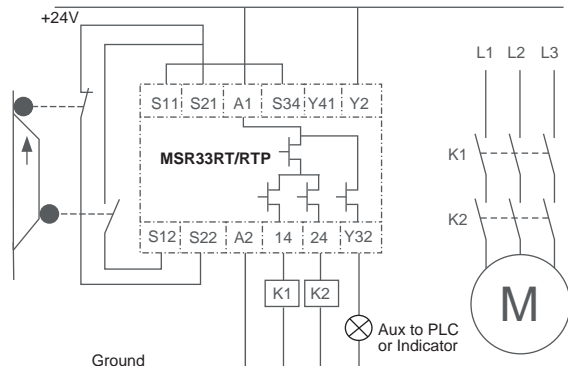

**Dual Independent Inputs, Dual Channel Outputs, Automatic Reset, No Output Monitoring Start-up Test Disabled**

5-Safety Relays

Logic  
**Single-Function Safety Relays**  
**MSR41**



**Description**

The MSR41 safety relay is a simple on/off control module for the GuardShield Micro 400 safety light curtain. This Category 4, SIL CL3 safety device has a pair of PNP solid state, 400 mA OSSDs for direct connection to the final switching device. When safety relay outputs are required, the MSR41 easily accommodates the interconnection of up to three MSR45E safety relay expansion modules, each providing a pair of safety relay outputs. Simply connect ribbon cable connectors from the back of the MSR41 to each of the MSR45E modules for a series of interconnections for two PNP OSSDs, and six N.O. relay outputs.

This 22.5 mm DIN mount safety relay can only be configured through hard-wired configurations. This relay module does not support configuration through the software but can be used for diagnostics only. The removable spring terminal connectors on the MSR41 allow for ease of wiring of the device as well as hard-wired operating mode configuration.

Manual/automatic reset and start/restart can be configured by simply changing the wiring (see examples).

**Features**

- Category 4 per EN 954-1
- SIL CL3 IEC 61508, IEC 62061
- 22.5 mm housing
- Stop category 0
- 24V DC supply voltage
- Manual or automatic reset
- Eight diagnostic LEDs
- Unique design allows for easy addition of relay expansion modules
- Removable terminal blocks
- Two auxiliary and standard outputs
- RJ45 connections for Micro 400 safety light curtain
- Supports up to three MSR45E expander units

**LED Indicators (Default Configuration)**

LED	Green	Red
OSSD2	Output active	Output inactive
OSSD1	Output active	Output inactive
Info2 (LED)	System OK	Lockout
Info1 (LED)	Safety Outputs ON	Safety Outputs OFF
IN2	Reset OK	Waiting for reset signal
IN1	—	—
0V	—	—
+24V	Power connected	No power connected

**Specifications**

<b>Safety Ratings</b>	
Standards	EN 954-1, IEC/EN 60204-1, IEC 61496-1
Safety Classification	Cat. 4 per EN 954-1 (ISO 13849-1), SIL CL3 per EN IEC 61508, PLe per ISO 13849-1
Functional Safety Data * <b>Note:</b> For up-to-date information, visit <a href="http://www.ab.com/Safety/">http://www.ab.com/Safety/</a>	PFD: 2.92E-09 (w LC) SFF: 96.40% (w LC) For use in SIL3 systems (according to IEC 61508) depending on the architecture and application characteristics
Certifications	CE Marked for all applicable directives, cULus, and TÜV
<b>Power Supply</b>	
Input Power Entry	24V DC
Power Consumption	2.4 W (semi-conductor outputs unloaded)
<b>Inputs</b>	
Safety Inputs	GuardShield Micro 400 Light Curtain
Input Resistance, Max.	—
Reset	Auto./manual
Power On Delay Time	Determined by configuration
Response Time	Determined by configuration
<b>Outputs</b>	
Safety Contacts	2 PNP, 400 mA each
Auxiliary Contacts	2 PNP
<b>Environmental and Physical Characteristics</b>	
Enclosure Type Rating/ Terminal Protection	IP20/ IP20
Operating Temperature [C (F)]	0...55 ° (32...131 °)
Vibration	0.35 mm 10...55 Hz
Mounting	35 mm DIN Rail
Weight [g (lbs)]	130 (0.287)
Conductor Size, Max.	1 x 2.5 mm <sup>2</sup> (14 AWG) stranded

\* Usable for IEC 62061. Data is based on the following assumptions:  
 - Mission time/Proof test interval of 20 years

**Product Selection**

Inputs	Safety Outputs	Auxiliary Outputs	Terminals	Reset Type	Power Supply	Cat. No.
GuardShield Micro 400	2 PNP	2 PNP	Removable	Auto./manual	24V DC	<b>440R-P221AGS</b>

**Accessories**

Description	Cat. No.
MSR45E—expander for MSR41 and MSR42	440R-P4NANS
Ribbon cable—for one MSR45E	<b>440R-ACABL1</b>
Ribbon cable—for two MSR45Es	440R-ACABL2
Ribbon cable—for three MSR45Es	440R-ACABL3
Replacement terminal block—MSR41	440R-ATERM1P
Replacement terminal block kit—MSR45E	440R-ATERM2C

**Approximate Dimensions**

Dimensions are shown in mm (in.). Dimensions are not intended to be used for installation purposes.

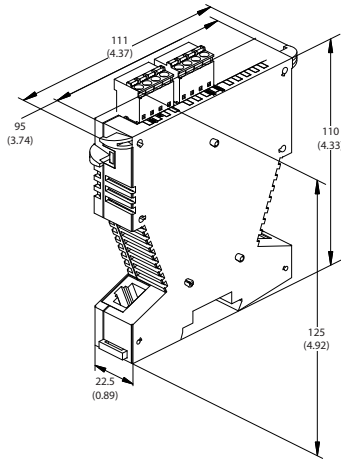

**Typical Wiring Diagrams**

**Default Configurations (No Software)**

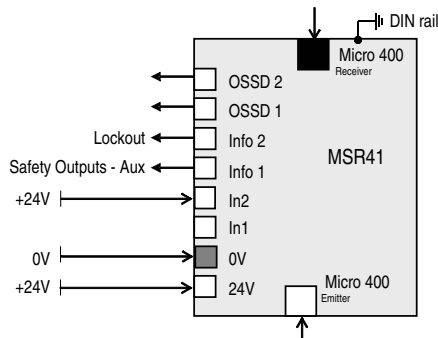

**Micro 400 Light Curtain, Automatic Reset, No Output Monitoring**

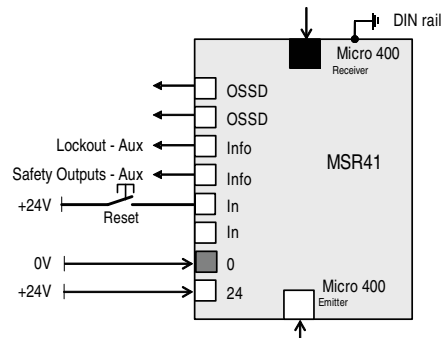

**Micro 400 Light Curtain, Manual Reset, No Output Monitoring**

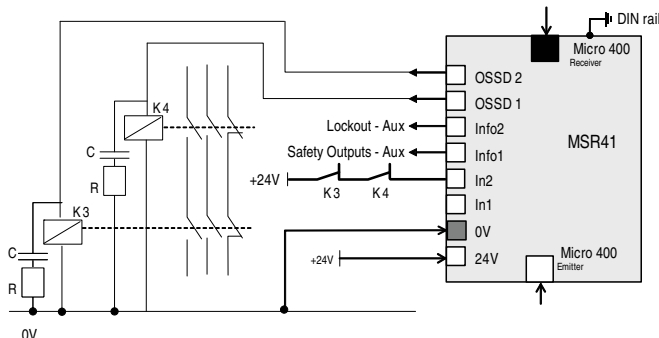

**Micro 400 Light Curtain, Manual Reset, Output Monitoring**

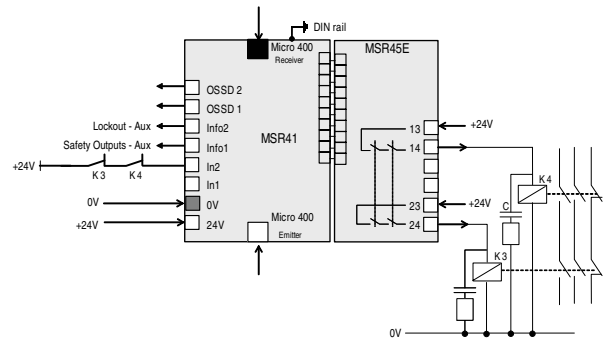

**Micro 400 Light Curtain, Automatic Reset, Output Monitoring**

# Single-Function Safety Relays

## MSR117T



### Description

The MSR117T has one normally closed single-channel input for use with gate interlocks and emergency stop buttons in lower risk applications. The MSR117T has output monitoring that can accommodate an automatic/manual reset function. Automatic/manual reset can use a jumper or can be used to check operation of the contacts.

The MSR117T has three normally open safety outputs and one normally closed auxiliary output. The safety outputs have independent and redundant internal contacts to help ensure the safety function. The auxiliary contact is a nonsafety output intended to provide an external signal about the status of the safety outputs.

The MSR117T can be activated via the terminals A1-A2 and the feedback/reset loop X1-X2. Then the safety outputs 13-14, 23-24 and 33-34 close and enable operation.

### Features

- Category 4 per EN 954-1
- Stop category 0
- Single channel input
- Three N.O. safety outputs
- One N.C. auxiliary output
- 22.5 mm wide housing

### Specifications

Safety Ratings	
Standards	IEC/EN 60204-1, ISO 12100, ISO 13849-1 (EN 954-1)
Safety Classification	Cat. 4 per EN 954-1 (ISO 13849-1), SIL CL3 per EN IEC 62061, PLe per ISO 13849-1
Functional Safety Data * <b>Note:</b> For up-to-date information, visit <a href="http://www.ab.com/Safety/">http://www.ab.com/Safety/</a>	PFH <sub>D</sub> : < 2.53 x 10 <sup>-9</sup> MTTF <sub>D</sub> : > 425 years Suitable for performance levels Pl <sub>e</sub> (according to ISO 13849-1:2006) and for use in SIL3 systems (according to IEC 62061) depending on the architecture and application characteristics
Certifications	CE Marked for all applicable directives, cULus, and TÜV
Power Supply	
Input Power Entry	24V AC/DC
Power Consumption	2 W
Inputs	
Safety Inputs	1 N.C.
Input Resistance, Max.	25 ohms
Reset	Auto./Manual or Monitored Manual
Power On Delay/Recovery Time	1 sec/110 ms
Response Time	30 ms
Outputs	
Safety Contacts	3 N.O.
Auxiliary Contacts	1 N.C.
Thermal Current <sub>I<sub>th</sub></sub>	2 x 5 A or 3 x 4 A
Rated Impulse withstand Voltage	2500V
Switching Current @ Voltage, Min.	10 mA @ 10V
Fuses, Output	6 A slow blow or 10 A quick blow (external)
Electrical Life	230V AC/4 A/880V A cosφ=0.35...0.1 M 230V AC/1.7 A/375V A cosφ=0.6...0.5 M 30V DC/2 A/60 = 1 M 10V DC/0.01 A/0.1 W = 2 M
Mechanical Life	2,000,000 cycles
Environmental and Physical Characteristics	
Enclosure Type Rating/ Terminal Protection	IP40 (NEMA 1), DIN 0470/ IP20, DIN 0470
Operating Temperature [C (F)]	-5...+55 ° (23...131 °)
Vibration	10...55 Hz, 0.35 mm
Shock	10 g, 16 ms 100 shocks
Mounting	35 mm DIN Rail
Weight [g (lbs)]	180 (0.37)
Conductor Size, Max.	0.2...4 mm <sup>2</sup> (24...12 AWG) wire size only

\* Usable for ISO 13849-1:2006 and IEC 62061. Data is based on the following assumptions:  
 - Mission time/Proof test interval of 20 years  
 - Functional test at least once within six-month period

### Applications

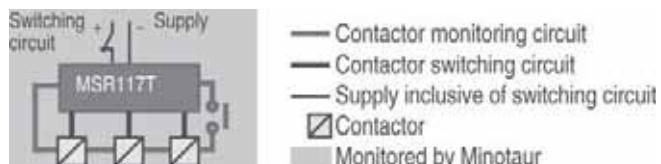

**Product Selection**

Inputs	Safety Outputs	Auxiliary Outputs	Terminals	Reset Type	Power Supply	Cat. No.
1 N.C.	3 N.O.	1 N.C.	Fixed	Auto./Manual or Monitored Manual	24V AC/DC	440R-B23211

**Approximate Dimensions**

Dimensions are shown in mm (in.).  
 Dimensions are not intended to be used  
 for installation purposes.

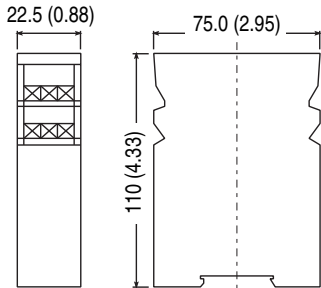

**Connections**

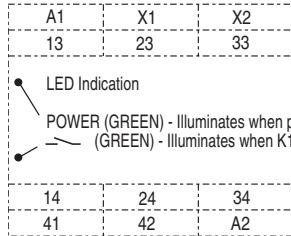

**Block Diagram**

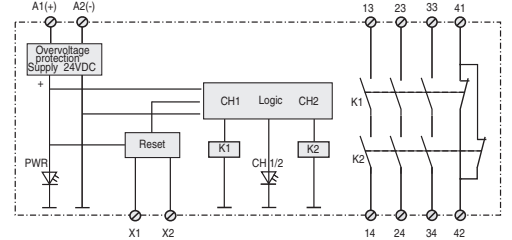

**Typical Wiring Diagrams**

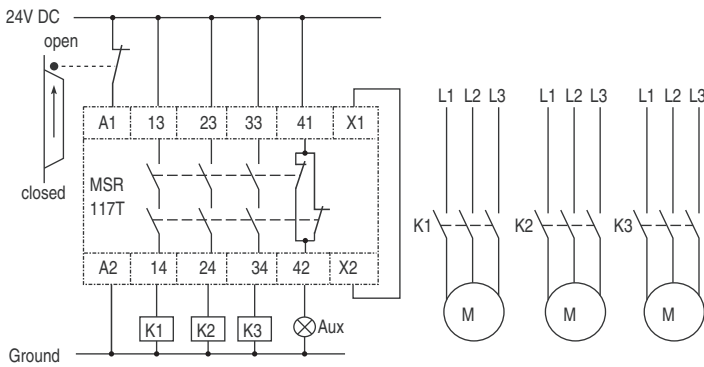

**Single Channel Gate Interlock, Automatic Reset,  
 Single Channel Output, No Monitored Output**

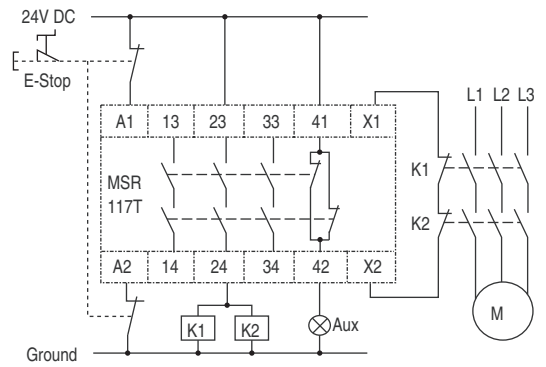

**Dual Channel E-Stop, Automatic Reset,  
 Single Channel Output, Monitored Output**

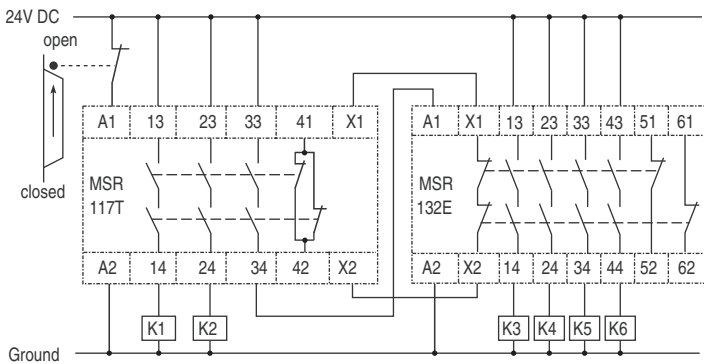

**Single Channel Gate Interlock, Automatic Reset,  
 Single Channel Output Expansion**

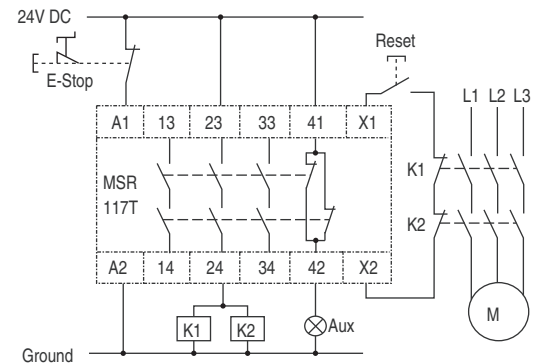

**Single Channel E-Stop, Manual Reset,  
 Single Channel Output, Monitored Output**

5-Safety Relays

# Single-Function Safety Relays

## MSR126RT



### Description

The Allen-Bradley Guardmaster Minotaur MSR126R/T is a safety monitoring relay that provides the very basics for safety control systems in a 22.5 mm package.

The MSR126R/T is designed for connection to a single channel safety gate, a single channel e-stop or a light curtain that provides cross fault detection. The MSR126.1R/T is designed for connection to a dual channel safety gate or e-stop, as it performs cross fault detection across the inputs.

The MSR126R and MSR126.1R are designed for applications where a monitored manual reset is required. Monitored manual reset requires the use of a momentary normally open switch to activate the outputs.

The MSR126T and MSR126.1T are designed for applications where automatic/manual reset is required.

The outputs are only two normally open safety-rated outputs. The safety outputs have independent and redundant internal contacts to support the safety function.

### Features

- Category 4 per EN 954-1
- Stop category 0
- Two safety contacts N.O.
- Single/dual channel operation
- Cross fault monitoring
- Monitored or automatic reset
- E-stop, safety gate or light curtain applications

### LED Indicators

Green	Power On
Green	K1 Closed
Green	K2 Closed

### Specifications

Safety Ratings	
Standards	EN 954-1, ISO 13849-1, IEC/EN 60204-1, IEC 60947-4-1, IEC 60947-5-1, ANSI B11.19, AS 4024.1
Safety Classification	Cat. 4 per EN 954-1 (ISO 13849-1), SIL CL3 per EN IEC 62061, PLe per ISO 13849-1
Functional Safety Data * <b>Note:</b> For up-to-date information, visit <a href="http://www.ab.com/Safety/">http://www.ab.com/Safety/</a>	PFH <sub>D</sub> : < 1.45 x 10 <sup>-9</sup> MTTF <sub>d</sub> : > 398 years Suitable for performance levels PLe (according to ISO 13849-1:2006) and for use in SIL3 systems (according to IEC 62061) depending on the architecture and application characteristics
Certifications	CE Marked for all applicable directives, cULus, c-Tick, and BG
Power Supply	
Input Power Entry	24V AC/DC, 115/230V AC
Power Consumption	4 W
Inputs	
Safety Inputs	1 N.C., 2 N.C., or LC
Input Simultaneity	Infinite
Input Resistance, Max.	90 Ω
Reset	Auto./Manual or Monitored Manual
Power On Delay/Recovery Time	300 ms/100 ms
Response Time	15 ms
Outputs	
Safety Contacts	2 N.O.
Thermal Current/ <i>I<sub>th</sub></i>	Max 6 A in one current path (nonswitching)
Rated Impulse withstand Voltage	2500V
Switching Current @ Voltage, Min.	10 mA @ 10V
Fuses, Output	External 6 A slow blow or 10 A fast acting
Electrical Life (Operations)	(With surge suppression) 250V AC/6 A/1500VA cosφ = 1...0.1 M 250V AC/2.5 A/625VA cosφ = 1...0.5 M 250V AC/1.5 A/375VA cosφ = 0.35...0.3 M 250V AC/5 A/1250VA cosφ = 0.6...0.1 M 24V DC/2 A/48 W = 1 M 10V DC/0.01 A/0.1 W = 2 M
Mechanical Life	2,000,000 operations
Utilization Category	
Resistive: AC-1	6 A/250V AC
Resistive: DC-1	6 A/24V DC
Inductive: AC-15	6 A/250V AC
Inductive: DC-13	3 A/24V DC
	6 A/125V AC
	6 A/24V DC @ 6 ops/min
Environmental and Physical Characteristics	
Enclosure Type Rating/ Terminal Protection	IP40 (NEMA 1), DIN 0470/ IP20, DIN 0470
Operating Temperature [C (F)]	-5...+55 ° (23...131 °)
Vibration	10...55 Hz, 0.35 mm
Shock	10 g, 16 ms 100 shocks
Mounting	35 mm DIN Rail
Weight [g (lbs)]	24V DC: 160 (0.35); 115/230V AC: 215 (0.47)
Conductor Size, Max.	0.2...4 mm <sup>2</sup> (24...12 AWG)

\* Usable for ISO 13849-1:2006 and IEC 62061. Data is based on the following assumptions:  
 - Mission time/Proof test interval of 20 years  
 - Functional test at least once within six-month period

**Product Selection**

Inputs	Safety Outputs	Auxiliary Outputs	Terminals	Reset Type	Power Supply	Cat. No.
Light Curtain or Single Channel (MSR126T)	2 N.O.	None	Fixed	Auto./Manual	24V AC/DC	<b>440R-N23117</b>
					115V AC	440R-N23116
					230V AC	440R-N23115
Monitored Manual					24V AC/DC	<b>440R-N23114</b>
					115V AC	440R-N23113
					230V AC	440R-N23112
Light Curtain or Single Channel (MSR126R)				24V AC/DC	440R-N23123	
					115V AC	440R-N23122
					230V AC	440R-N23121
Dual Channel 2 N.C. (MSR126.IT)	24V AC/DC	440R-N23120				
		115V AC	440R-N23119			
		230V AC	440R-N23118			

**Approximate Dimensions**

Dimensions are shown in mm (in.). Dimensions are not intended to be used for installation purposes.

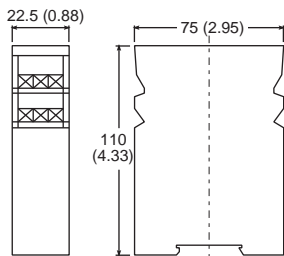

**Block Diagram**

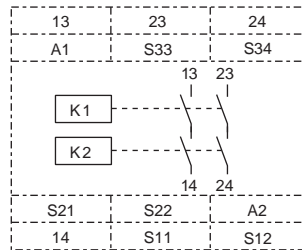

**Typical Wiring Diagrams**

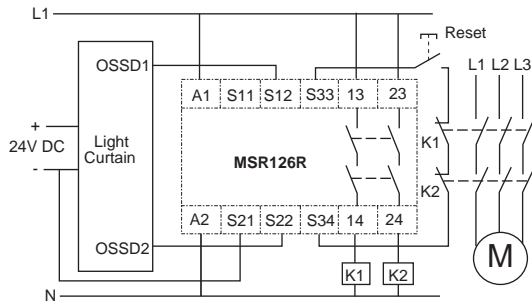

**115/230V Supply, 24V DC Light Curtain, Monitored Manual Reset, Monitored Output**

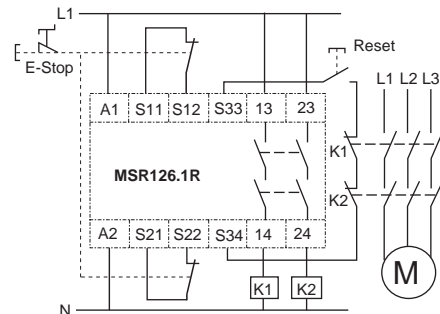

**Dual Channel E-Stop Input, Monitored Manual Reset, Monitored Output**

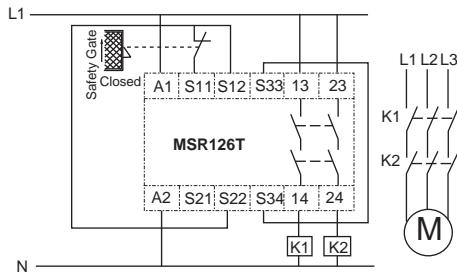

**Single Channel Safety Gate, Automatic Reset, No Output Monitoring**

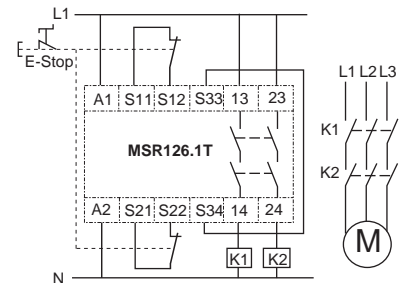

**Dual Channel E-Stop, Automatic Reset, No Output Monitoring**

**5-Safety Relays**

Logic  
**Single-Function Safety Relays**  
**MSR127RTP**



**Description**

The MSR127RTP can be connected in three different input wiring configurations: one normally closed, two normally closed, or with two PNP connections from a light curtain. When connected in the two normally closed fashion, the MSR127RTP checks for cross faults across the two inputs. When connected to light curtains, the light curtain must perform the cross fault detection.

The MSR127RP has a monitored manual reset. The MSR127TP has an automatic/manual reset. Models with automatic/manual reset can have the reset jumpered or can be converted to an unmonitored manual reset by adding a normally open switch in the monitoring loop. Models with monitored manual reset provide checking of the output monitoring circuit.

The outputs include three normally open safety-rated outputs as well as one normally closed auxiliary output. The safety outputs have independent and redundant internal contacts to support the safety function. The auxiliary output is a nonsafety output intended to provide an external signal about the status of the safety outputs.

**Features**

- Category 4 per EN 954-1
- Stop category 0
- Three safety contacts
- One auxiliary contact
- Cross fault monitoring
- Monitored or automatic reset
- Removable terminals
- Light curtain, E-stop or safety gate applications

**LED Indicators**

Green	Power On
Green	CH1 Closed
Green	CH2 Closed

**Specifications**

<b>Safety Ratings</b>	
Standards	EN 954-1, ISO 13849-1, IEC/EN 60204-1, IEC 60947-4-1, IEC 60947-5-1, ANSI B11.19, AS4024.1
Safety Classification	Cat. 4 per EN 954-1 (ISO 13849-1), SIL CL3 per EN IEC 62061, PLe per ISO 13849-1
Functional Safety Data * <b>Note:</b> For up-to-date information, visit <a href="http://www.ab.com/Safety/">http://www.ab.com/Safety/</a>	PFH <sub>D</sub> : < 1.45 x 10 <sup>-9</sup> MTTF <sub>d</sub> : > 398 years Suitable for performance levels PLe (according to ISO 13849-1:2006) and for use in SIL3 systems (according to IEC 62061) depending on the architecture and application characteristics
Certifications	CE Marked for all applicable directives, cULus and BG
<b>Power Supply</b>	
Input Power Entry	24V AC/DC, 115V AC or 230V AC 50/60 Hz
Power Consumption	2 W
<b>Inputs</b>	
Safety Inputs	1 N.C. or 2 N.C. or LC
Input Simultaneity	Infinite (ch2 before ch1) with Auto Reset
Input Resistance, Max.	110 Ω
Reset	Auto./Manual or Monitored Manual
Power On Delay/Recovery Time	1 second/100 ms
Response Time	15 ms
<b>Outputs</b>	
Safety Contacts	3 N.O.
Auxiliary Contacts	1 N.C.
Thermal Current/ <i>I<sub>th</sub></i>	Units with 24V AC/DC supply: 3 x 4 A or 2 x 5 A nonswitching Units with 115/230V AC supplies: 3 x 3 A or 2 x 4 A or 1 x 5 A nonswitching
Rated Impulse withstand Voltage	2500V
Switching Current @ Voltage, Min.	10 mA/10V
Fuses, Output	External 6 A slow blow or 10 A fast acting
Electrical Life (Operations)	(With surge suppression) 250V AC/6 A/1500VA cosφ = 1...0.1 M 250V AC/2.5 A/625VA cosφ = 1...0.5 M 250V AC/1.5 A/375VA cosφ = 0.35...0.3 M 250V AC/5 A/1250VA cosφ = 0.6...0.1 M 24V DC/2 A/48 W = 1 M 10V DC/0.01 A/0.1 W = 2 M
Mechanical Life	2,000,000 operations
<b>Utilization Category</b>	
Resistive: AC-1	5 A/250V AC
Resistive: DC-1	5 A/24V DC
Inductive: AC-15	5 A/250V AC
Inductive: DC-13	3 A/24V DC
	5 A/24V DC @ 6 ops/min
<b>Environmental and Physical Characteristics</b>	
Enclosure Type Rating/Terminal Protection	IP40 (NEMA 1)/IP20
Operating Temperature [C (F)]	-5...+55 ° (23...131 °)
Vibration	10...55 Hz, 0.35 mm
Shock	10 g, 16 ms 100 shocks
Mounting	35 mm DIN Rail
Weight [g (lbs)]	24V DC: 210 (0.46), 115/230V AC: 260 (0.57)
Conductor Size, Max.	0.2...4 mm <sup>2</sup> (24...12 AWG)

\* Usable for ISO 13849-1:2006 and IEC 62061. Data is based on the following assumptions:  
 - Mission time/Proof test interval of 20 years  
 - Functional test at least once within six-month period

**Product Selection**

Inputs	Safety Outputs	Auxiliary Outputs	Terminals	Reset Type	Power Supply	Cat. No.	
1 N.C., 2 N.C., Light Curtain	3 N.O.	1 N.C.	Fixed	Auto./Manual	24V AC/DC	<b>440R-N23126</b>	
				Monitored Manual		440R-N23129	
				Auto./Manual	115V AC	440R-N23125	
				Monitored Manual		440R-N23128	
				Auto./Manual	230V AC	440R-N23124	
				Monitored Manual		440R-N23127	
			Removable (Screw)	Auto./Manual	24V AC/DC	<b>440R-N23132</b>	
				Monitored Manual		<b>440R-N23135</b>	
				Removable (Spring Clamp)	Auto./Manual	24V AC/DC	440R-N23132S
					Monitored Manual		440R-N23135S
				Removable (Screw)	Auto./Manual	115V AC	<b>440R-N23131</b>
					Monitored Manual		440R-N23134
Auto./Manual	230V AC	440R-N23130					
Monitored Manual		440R-N23133					

**Accessories**

Description	Cat. No.
4 Replacement 4-pin Terminals (screw)	440R-A23209
4 Replacement 4-pin Terminals (spring clamp)	440R-A23228

**Approximate Dimensions**

Dimensions are shown in mm (in.). Dimensions are not intended to be used for installation purposes.

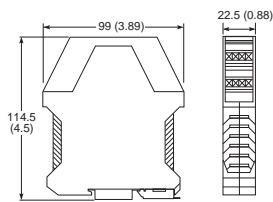

**Block Diagram**

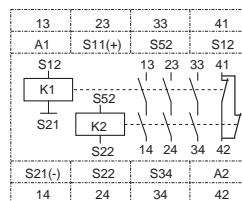

**Typical Wiring Diagrams**

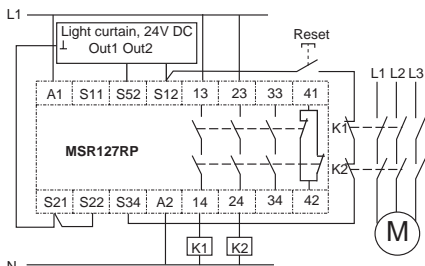

**Light Curtain, Monitored Manual Reset, Monitored Output**

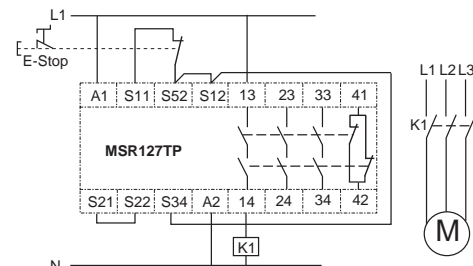

**Single Channel E-Stop, Automatic Reset, No Output Monitoring**

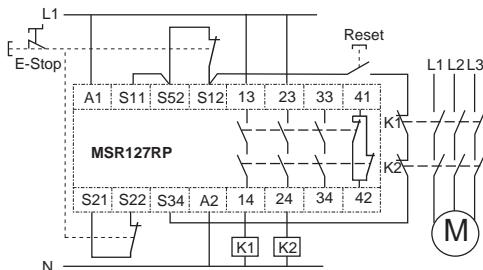

**Dual Channel E-Stop, Monitored Manual Reset, Monitored Output**

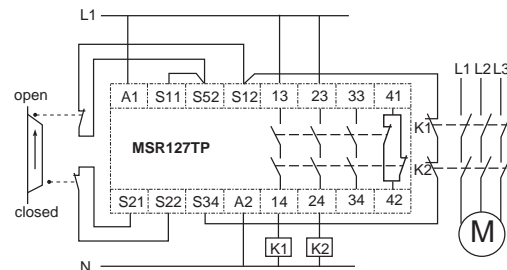

**Dual Channel Safety Gates, Automatic Reset, Monitored Output**

**5-Safety Relays**

Logic  
**Single-Function Safety Relays**  
**MSR131RTP**



**Description**

The MSR131RTP is a versatile monitoring safety relay. It can be connected in four different input wiring configurations: one normally closed, 2 normally closed, 2 PNP connections from a light curtain, or a four-wire safety mat. When connected in the two normally closed fashion, the MSR131RTP checks for cross faults across the two inputs. When connected to light curtains, the light curtain must perform the cross-fault detection.

The MSR131RTP has output monitoring that can accommodate either automatic/manual reset or a monitored manual reset. When configured with automatic/manual reset (jumpers on X1-X2 and X3-X4), the MSR131RTP can have the reset terminals S33-S34 jumpered or can be converted to an unmonitored manual reset by adding a normally open switch in the monitoring loop (S33-S34). When configured to monitored manual reset, the MSR131RTP checks the output monitoring circuit through the manual application of the reset switch.

The outputs include three normally open safety rated outputs, two normally closed auxiliary outputs, and two solid-state outputs. One solid-state output indicates that the inputs are closed. The second solid-state output indicates that the safety outputs are active.

The safety outputs have independent and redundant internal contacts to help ensure the safety function. The auxiliary output is a nonsafety output intended to provide an external signal about the status of the safety outputs.

**Features**

- Category 4 per EN 954-1
- Stop category 0
- Light curtain, safety mat, E-stop inputs
- Three safety contacts
- Two auxiliary contact
- Two solid-state outputs
- Cross fault monitoring
- Monitored or automatic reset
- Removable terminals

**LED Indicators**

Green	Power
Green	Start
Green	CH1 Input Closed
Green	CH2 Input Closed
Green	CH1 Output Active
Green	CH2 Output Active

**Specifications**

Safety Ratings		
Standards	EN 954-1, ISO 13849-1, IEC/EN 60204-1, IEC 60947-4-1, IEC 60947-5-1, ANSI B11.19, AS4024.1	
Safety Classification	Cat. 4 per EN 954-1 (ISO 13849-1), SIL CL3 per EN IEC 62061, PLe per ISO 13849-1	
Functional Safety Data * Note: For up-to-date information, visit <a href="http://www.ab.com/Safety/">http://www.ab.com/Safety/</a>	PFH <sub>D</sub> : < 1.67 x 10 <sup>-9</sup> MTTF <sub>d</sub> : > 389 years Suitable for performance levels PLe (according to ISO 13849-1:2006) and for use in SIL3 systems (according to IEC 62061) depending on the architecture and application characteristics	
Certifications	CE Marked for all applicable directives, cULus, BG, and c-Tick	
Power Supply		
Input Power Entry	24V AC/DC, 115V AC or 230V AC	
Power Consumption	4 W	
Inputs		
Safety Inputs	1 N.C., 2 N.C., LC or SM	
Input Simultaneity	Infinite	
Input Resistance, Max.	45 Ω	
Reset	Auto./Manual or Monitored Manual	
Power On Delay/Recovery Time	1 second/100 ms	
Response Time	15 ms	
Outputs		
Safety Contacts	3 N.O.	
Auxiliary Contacts	2 N.C.; 1 SS PNP inputs closed; 1 SS PNP outputs active; 30V DC/20 mA solid state	
Thermal Current/ <i>I<sub>th</sub></i>	1 x 6 A or 3 x 5 A nonswitching	
Rated Impulse withstand Voltage	2500V	
Switching Current @ Voltage, Min.	10 mA @ 10V	
Fuses, Output	External 6 A slow blow or 10 A fast acting	
Electrical Life (Operations)	(With surge suppression) 250V AC/6 A/1500VA cosφ = 1...0.1 M 250V AC/2.5 A/625VA cosφ = 1...0.5 M 250V AC/1.5 A/375VA cosφ = 0.35...0.3 M 250V AC/5 A/1250VA cosφ = 0.6...0.1 M 24V DC/2 A/48 W = 1 M 10V DC/0.01 A/0.1 W = 2 M	
Mechanical Life	2,000,000 operations	
Utilization Category		
Resistive: AC-1	6 A/250V AC	
Resistive: DC-1	6 A/24V DC	
Inductive: AC-15	6 A/250V AC	6 A/125V AC
Inductive: DC-13	3 A/24V DC	6 A/24V DC @ 6 ops/min
UL	B300, R300, 1 x 6 A or 2 x 5 A resistive/250V AC, 24V DC	
Environmental and Physical Characteristics		
Enclosure Type Rating/ Terminal Protection	IP40 (NEMA 1)/ IP20	
Operating Temperature [C (F)]	-5...+55 ° (23...131 °)	
Vibration	10...55 Hz, 0.35 mm	
Shock	10 g, 16 ms 100 shocks	
Mounting	45 mm housing, 35 mm DIN Rail	
Weight [g (lbs)]	24V DC: 320 (0.71) 115/230V AC: 450 (0.99)	
Conductor Size, Max.	0.2...4 mm <sup>2</sup> (24...12 AWG)	

\* Usable for ISO 13849-1:2006 and IEC 62061. Data is based on the following assumptions:  
 - Mission time/Proof test interval of 20 years  
 - Functional test at least once within six-month period

**Product Selection**

Inputs	Safety Outputs	Auxiliary Outputs	Terminals	Reset Type	Power Supply	Cat. No.
1 N.C., 2 N.C., Light Curtain, Safety Mat	3 N.O.	2 N.C., 2 PNP Solid State	Removable (Screw)	Auto./Manual or Monitored Manual	24V AC/DC	440R-C23139
			Removable (Spring Clamp)			440R-C23139S
			Removable (Screw)			440R-C23137
					230V AC	440R-C23136

**Accessories**

Description	Cat. No.
Bag of 4, 4-Pin Screw Terminal Blocks	440R-A23209
Bag of 4, 4-Pin Spring Clamp Terminal Blocks	440R-A23228

**Approximate Dimensions**

Dimensions are shown in mm (in.). Dimensions are not intended to be used for installation purposes.

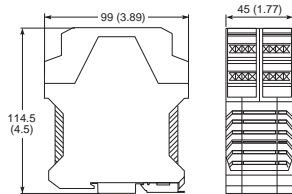

**Block Diagram**

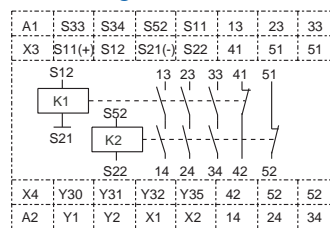

**Typical Wiring Diagrams**

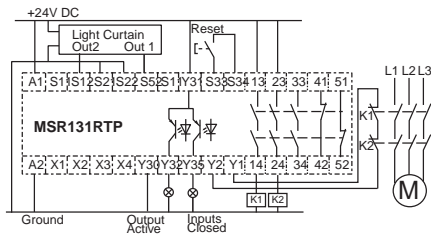

**Light Curtain, Monitored Manual Reset, Monitored Output**

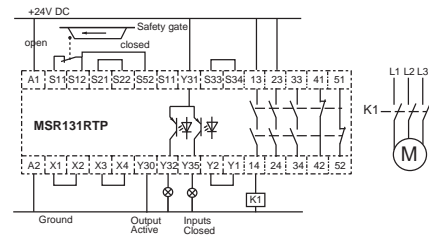

**Single Channel Safety Gate, Automatic Reset, No Output Monitoring**

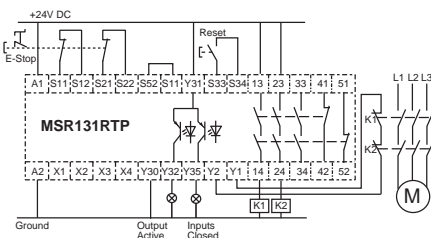

**Dual Channel E-Stop, Monitored Manual Reset, Monitored Output**

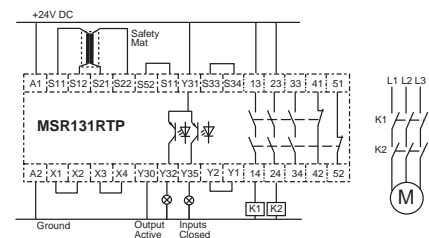

**Safety Mat, Automatic Reset, No Output Monitoring**

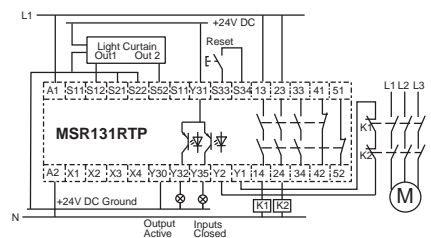

**115/230V AC Supply, 24V DC, Light Curtain, Monitored Manual Reset, Monitored Output**

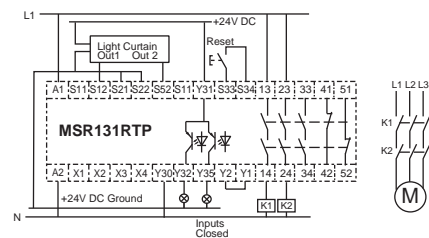

**115/230V AC Supply, 24V DC, Light Curtain, Monitored Manual Reset, No Output Monitoring**

5-Safety Relays

Logic  
**Single-Function Safety Relays**  
**MSR142RTP**



**Description**

The MSR142RTP is a versatile monitoring safety relay. It can be connected in four different input wiring configurations: one normally closed, two normally closed, two PNP connections from a light curtain, or a four-wire safety mat. When connected in the two normally closed fashion, the MSR142RTP checks for cross faults across the two inputs. When connected to light curtains, the light curtain must perform the cross-fault detection.

The MSR142RTP has output monitoring that can accommodate either automatic/manual reset or a monitored manual reset. When configured with automatic/manual reset (jumpers on X1-X2 and X3-X4), the MSR142RTP can have the reset terminals S33-S34 jumpered or can be converted to an unmonitored manual reset by adding a normally open switch in the monitoring loop (S33-S34). When configured to monitored manual reset, the MSR142RTP checks the output monitoring circuit through the manual application of the reset switch.

The outputs include seven normally open safety-rated outputs, four normally closed auxiliary outputs, and two solid-state outputs. One solid-state output indicates that the inputs are closed. The second solid-state output indicates that the safety outputs are active. The safety outputs have independent and redundant internal contacts to support the safety function. The auxiliary outputs are nonsafety outputs intended to provide an external signal about the status of the safety outputs.

**Features**

- Category 4 per EN 954-1
- Stop category 0
- Light curtain, safety mat, E-stop inputs
- Seven electromechanical N.O. state safety outputs
- Four electromechanical N.C. auxiliary outputs
- Two solid-state auxiliary outputs
- Cross-fault monitoring
- Monitored or automatic reset
- Removable terminals

**LED Indicators**

Green	Power
Green	Start
Green	CH1 IN
Green	CH2 IN
Green	CH1 output energized
Green	CH2 output energized

**Specifications**

<b>Safety Ratings</b>	
Standards	EN 954-1, ISO 13849-1, IEC/EN 60204-1, IEC 60947-5-1, AS 4042.1, ISOTR 12100, B11.19
Safety Classification	Cat. 4 per EN 954-1 (ISO 13849-1), SIL CL3 per EN IEC 62061, PLe per ISO 13849-1
Functional Safety Data * <b>Note:</b> For up-to-date information, visit <a href="http://www.ab.com/Safety/">http://www.ab.com/Safety/</a>	PFHD: < 1.92 x 10 <sup>-9</sup> MTTFd: > 210 years Suitable for performance levels PLe (according to ISO 13849-1:2006) and for use in SIL3 systems (according to IEC 62061) depending on the architecture and application characteristics
Certifications	CE Marked for all applicable directives, cULus, TÜV, and c-Tick
<b>Power Supply</b>	
Input Power Entry	24V AC/DC, 115V AC or 230V AC 50/60 Hz
Power Consumption	5 W
<b>Inputs</b>	
Safety Inputs	1 N.C., 2 N.C., Light Curtain or 4-Wire Safety Mat
Input Simultaneity	Infinite
Input Resistance, Max.	45 ohms
Reset	Auto./Manual or Monitored Manual
Power On Delay/Recovery Time	1 s/100 ms
Response Time	15 ms
<b>Outputs</b>	
Safety Contacts	7 N.O.
Auxiliary Contacts	4 N.C., 2 PNP
Rated Impulse withstand Voltage	2500V
Switching Current @ Voltage, Min.	10 mA @ 10V DC
Fuses, Output	6 A slow blow or 10 A quick blow (external)
Electrical Life (Operations)	220V AC/4 A/880VA cosφ = 0.35...0.1 M 220V AC/1.7 A/375VA cosφ = 0.6...0.5 M 30V DC/2 A/60 W = 1 M 10V DC/0.01 A/0.1 W = 2 M
Mechanical Life	2,000,000 operations
<b>Utilization Category</b>	
Inductive: Safety & Aux.: AC-15	6 A/250V AC
Inductive: AC-13	3 A/24V DC
Resistive: DC-13	20 mA/30V DC short-circuit protected
UL	4 x B300 or 7 x 4 A Resistive
<b>Environmental and Physical Characteristics</b>	
Enclosure Type Rating/Terminal Protection	IP40 (NEMA 1), DIN VDE 0470-1/ IP20
Operating Temperature [C (F)]	-5...+55 ° (14...131 °)
Vibration	10...55 Hz, 0.35 mm
Shock	10 g, 16 ms, 100 shocks
Mounting	35 mm DIN Rail
Weight [g (lbs)]	24V: 470 (1.04); 115/230V AC: 607 (1.34)
Conductor Size, Max.	0.2...4 mm <sup>2</sup> (24...12 AWG)

\* Usable for ISO 13849-1:2006 and IEC 62061. Data is based on the following assumptions:  
 - Mission time/Proof test interval of 20 years  
 - Functional test at least once within six-month period

**Product Selection**

Inputs	Safety Outputs	Auxiliary Outputs	Terminals	Reset Type	Power Supply	Cat. No.
1 N.C., 2 N.C., Light Curtain, Safety Mat	7 N.O.	4 N.C., 2 PNP, Solid-state	Removable	Monitored Manual or Auto/Manual	24V AC/DC	<b>440R-G23216</b>
					115V AC	440R-G23215
					230V AC	440R-G23214

**Accessories**

Description	Cat. No.
Bag of 4, 4-Pin Screw Terminal Blocks	440R-A23209
Bag of 4, 4-Pin Spring Clamp Terminal Blocks	440R-A23228

**Approximate Dimensions**

Dimensions are shown in mm (in.). Dimensions are not intended to be used for installation purposes.

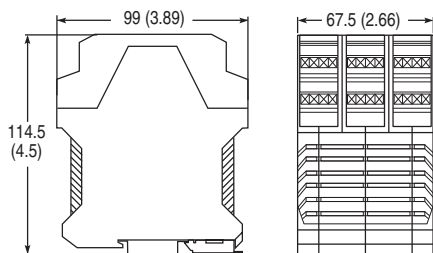

**Block Diagram**

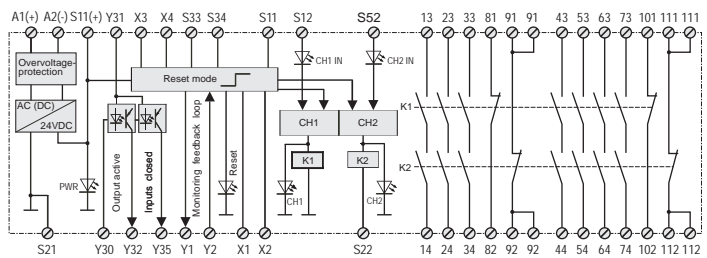

**Typical Wiring Diagrams**

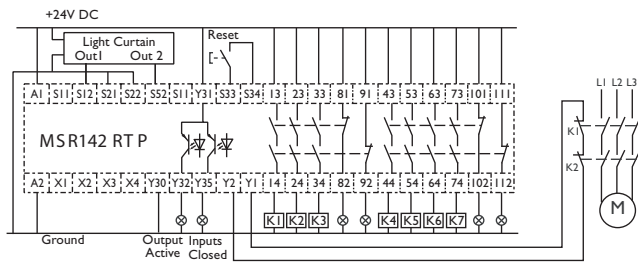

**Light Curtain, Monitored Manual Reset, Monitored Output**

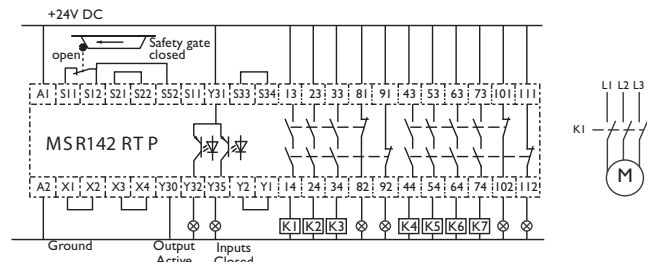

**Single Channel Safety Gate, Auto Reset, No Output Monitoring**

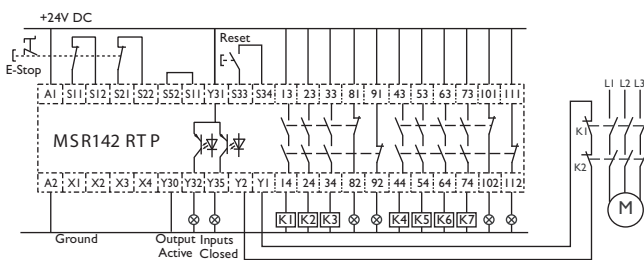

**Dual Channel E-Stop, Monitored Manual Reset, Monitored Output**

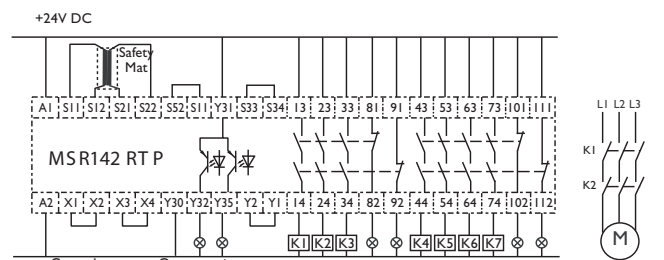

**Safety Mat, Automatic Reset, No Output Monitoring**

## Single-Function Safety Relays

## MSR144RTP



## Description

The MSR144RTP is a versatile monitoring safety relay. It can be connected in four different input wiring configurations: one normally closed, two normally closed, two PNP connections from a light curtain, or a four-wire safety mat. When connected in the two normally closed fashion, the MSR144RTP checks for cross faults across the two inputs. When connected to light curtains, the light curtain must perform the cross-fault detection.

Any combination of up to five MSR230 and MSR238 output modules can be easily connected to the MSR144RTP by removing the terminator, inserting a ribbon cable from the expander and then placing the terminator into the last expansion module.

The MSR144RTP has output monitoring that can accommodate either automatic/manual reset or a monitored manual reset. When configured with automatic/manual reset (jumpers on X1-X2 and X3-X4), the MSR144RTP can have the reset terminals S33-S34 jumpered or can be converted to an unmonitored manual reset by adding a normally open switch in the monitoring loop (S33-S34). When configured to monitored manual reset, the MSR144RTP checks the output monitoring circuit through the manual application of the reset switch.

The outputs include two normally open safety rated outputs, two normally closed auxiliary outputs, and two solid-state auxiliary outputs. One solid-state output indicates the inputs are closed. The second solid-state output indicates the safety outputs are active.

The safety outputs have independent and redundant internal contacts to help ensure the safety function. The auxiliary outputs are nonsafety outputs intended to provide an external signal about the status of the safety outputs.

## Features

- Category 4 per EN 954-1
- Stop category 0 or 1 (with MSR238)
- Light curtain, safety mat, E-stop inputs
- Two N.O. safety outputs
- Two N.C. auxiliary outputs
- Two solid-state auxiliary outputs
- Cross-fault monitoring
- Monitored manual or automatic/manual
- Removable terminals
- Expansion for up to five modules

## LED Indicators

Green	Power
Green	Start
Green	CH1 IN
Green	CH2 IN
Green	CH1 output energized
Green	CH2 output energized

## Specifications

<b>Safety Ratings</b>	
Standards	EN 954-1, ISO 13849-1, IEC/EN 60204-1, AS 4024.1, ISOTR 12100
Safety Classification	Cat. 4 per EN 954-1 (ISO 13849-1), SIL CL3 per EN IEC 62061, PLe per ISO 13849-1
Functional Safety Data *	PFH <sub>D</sub> : < 1.67 x 10 <sup>-9</sup> MTTF <sub>D</sub> : > 389 years <b>Note:</b> For up-to-date information, visit <a href="http://www.ab.com/Safety/">http://www.ab.com/Safety/</a>
Certifications	CE Marked for all applicable directives, cULus, TÜV, and c-Tick
<b>Power Supply</b>	
Input Power Entry	24V DC
Power Consumption	4 W + expanders
<b>Inputs</b>	
Safety Inputs	1 N.C., 2 N.C., LC or 4-wire safety mat
Input Simultaneity	Infinite
Input Resistance, Max.	45 ohms
Reset	Auto./Manual or Monitored Manual
Power On Delay/Recovery Time	1 s/100 ms
Response Time	15 ms
<b>Outputs</b>	
Safety Contacts	2 N.O.
Auxiliary Contacts	2 N.C., 2 PNP
Rated Impulse withstand Voltage	2500V
Switching Current @ Voltage, Min.	10 mA @ 10V DC
Fuses, Output	6 A slow blow or 10 A quick blow (external)
Electrical Life (Operations)	220V AC/4 A/880VA cosφ = 0.35...0.1 M 220V AC/1.7 A/375VA cosφ = 0.6...0.5 M 30V DC/2 A/60 W = 1 M 10V DC/0.01 A/0.1 W = 2 M
Mechanical Life	2,000,000 operations
<b>Utilization Category</b>	
Inductive: Safety & Aux.: AC-15	5 A/250V AC
Inductive: Safety & Aux.: DC-13	3 A/24V DC
UL	B300, R300, 1 x 6 A or 2 x 5 A resistive/250V AC, 24V DC
Solid State:	20 mA/30V DC short circuit protection
<b>Environmental and Physical Characteristics</b>	
Enclosure Type Rating/Terminal Protection	IP40 (NEMA 1), DIN VDE 0470-1/IP20
Operating Temperature [C (F)]	-5...+55 ° (23...131 °)
Vibration	10...55 Hz, 0.35 mm
Shock	10 g, 16 ms, 100 shocks
Mounting	35 mm DIN Rail
Weight [g (lbs)]	315 (0.71)
Conductor Size, Max.	0.2...4 mm <sup>2</sup> (24...12 AWG)

- \* Usable for ISO 13849-1:2006 and IEC 62061. Data is based on the following assumptions:
- Mission time/Proof test interval of 20 years
  - Functional test at least once within six-month period

**Product Selection**

Inputs	Safety Outputs	Auxiliary Outputs	Terminals	Reset Type	Power Supply	Cat. No.
1 N.C., 2 N.C., Light Curtain, Safety Mat	2 N.O.	2 N.C. 2 PNP solid-state	Removable	Monitored Manual or Auto/Manual	24V DC	440R-C23205

**Accessories**

Description	Cat. No.
Bag of 4, 4-Pin Screw Terminal Blocks	440R-A23209
Bag of 4, 4-Pin Spring Clamp Terminal Blocks	440R-A23228

**Approximate Dimensions**

Dimensions are shown in mm (in.). Dimensions are not intended to be used for installation purposes.

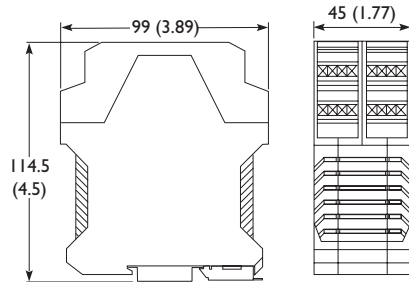

**Block Diagram**

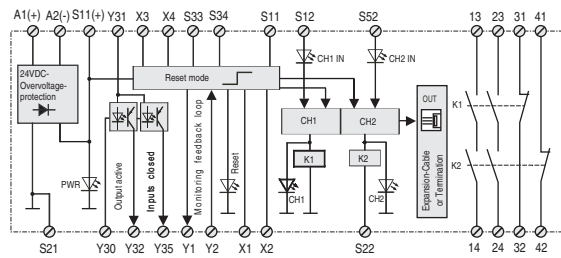

**Typical Wiring Diagrams**

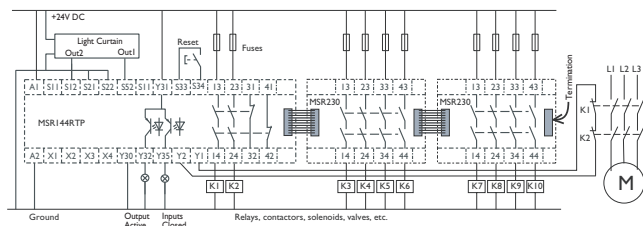

**Light Curtain, Manual Reset with Manual Reset**

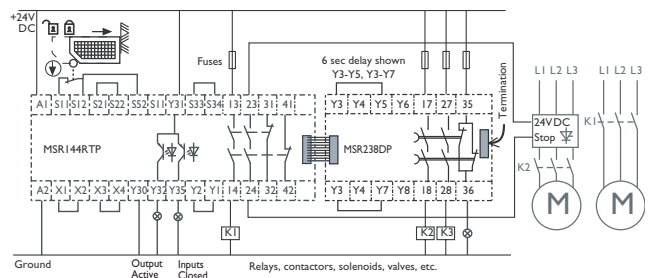

**115V/230V AC Supply, 24V DC, Dual Channel, Automatic Reset, Monitored Output**

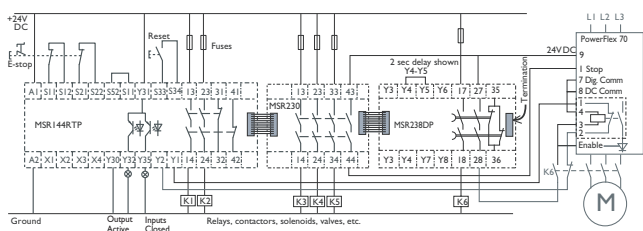

**Dual Channel E-Stop, Monitored Manual Reset, Monitored Output**

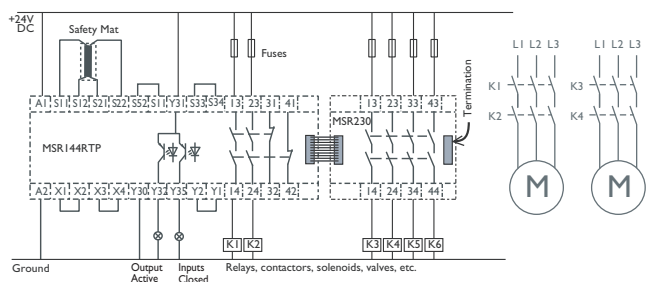

**Safety Mat, Automatic Reset, No Output Monitoring**

5-Safety Relays

## Single-Function Safety Relays with Delayed Outputs

## CU4



## Description

The CU4 is an off-delay timing unit which can be operated standalone or as an extension of a host relay. The timed outputs are used in applications where power must be maintained for a fixed duration after an input signal is received. For example, driving a power to lock TLS2-GD2 to maintain a guard door in the locked position for a fixed duration after a stop button is pressed. Another example would be maintaining the connection of a drive to a motor until the braking function is achieved, and then dropping out a contactor to remove power to the motor.

The inputs can be connected in either a single channel or dual channel configuration. The inputs must remain open during the complete timing cycle. Closing the contacts before the timing cycle completes causes the timer to be reset to zero.

The CU4 has a redundant structure with two independent safe timer circuits. The outputs include two normally open safety delayed outputs as well as one normally closed auxiliary output. The safety outputs have independent and redundant internal contacts to support the safety function. When used as an extension of a host relay, the normally closed contacts should be used in the feedback loop of the host relay. If used in standalone application, the normally closed contacts can be used to signal an auxiliary device or PLC.

A typical operation starts with power applied to A1/A2 and the input circuits open.

1. Close the B11/B12 and B21/B22 circuits.
  - a. The safety outputs (17/18 & 27/28) close immediately.
2. Open the B11/B12 or B21/B22 circuits.
  - a. The timing process starts.
  - b. The safety outputs (17/18 & 27/28) open after the time expires.
3. Go to Step 1.

## Features

- Category 3 per EN 954-1
- Stop category 1
- Timed off-delay 0.15...30 s
- Two safety contacts
- One auxiliary contact

## LED Indicators

Green	Power
Green	CH1 t1 Active
Green	CH2 t2 Active

## Specifications

<b>Safety Ratings</b>		
Standards	EN 954-1, ISO 13849-1, IEC/EN 60204-1, IEC 60947-5-1, ANSI B11.19, AS4024.1	
Safety Classification	Cat. 3 per EN 954-1 (ISO 13849-1), SIL CL2 per EN IEC 62061, PLe per ISO 13849-1	
Functional Safety Data *	PFH <sub>D</sub> : < 2.16 x 10 <sup>-9</sup> MTTF <sub>d</sub> : > 345 years <b>Note:</b> For up-to-date information, visit <a href="http://www.ab.com/Safety/">http://www.ab.com/Safety/</a>	
Certifications	CE Marked for all applicable directives, cULus, c-Tick, and BG	
<b>Power Supply</b>		
Input Power Entry	24V AC/DC, 50/60 Hz; 0.85...1.1 x rated voltage	
Power Consumption	2.5 W	
<b>Inputs</b>		
Safety Inputs	1 N.C. or 2 N.C.	
Input Simultaneity	Infinite	
Reset	Automatic	
Response Time	30 ms	
<b>Outputs</b>		
Safety Contacts	2 N.O.	
Auxiliary Contacts	1 N.C.	
Rated Impulse withstand Voltage	2500V	
Switching Current @ Voltage, Min.	10 mA/10V	
Fuses, Output	External 6 A slow blow or 10 A fast acting	
Electrical Life (Operations)	220V AC/4 A/880VA cosφ = 0.35...0.1 M 220V AC/1.7 A/375VA cosφ = 0.6...0.5 M 30V DC/2 A/60 W = 1 M 10V DC/0.01 A/0.1 W = 2 M	
Mechanical Life	2,000,000 operations	
<b>Utilization Category</b>		
AC-15	5 A @ 250V AC	5 A @ 125V AC
DC-13	3 A/24V DC	
UL:	B300, 5 A/250V AC, 24V DC	
<b>Environmental and Physical Characteristics</b>		
Enclosure Type Rating/ Terminal Protection	IP40, DIN 0470/ IP20	
Operating Temperature [C (F)]	-5...+55 ° (23...131 °)	
Vibration	10...55 Hz, 0.35 mm	
Shock	10 g, 16 ms, 100 shocks	
Mounting	35 mm DIN Rail	
Weight [g (lbs)]	165 (0.36)	
Conductor Size, Max.	0.2...4 mm <sup>2</sup> (24...12 AWG)	

- \* Usable for ISO 13849-1:2006 and IEC 62061. Data is based on the following assumptions:
- Mission time/Proof test interval of 20 years
  - Functional test at least once within six-month period

# Logic Single-Function Safety Relays with Delayed Outputs CU4

## Product Selection

Inputs	Safety Outputs	Auxiliary Outputs	Time Range	Reset Type	Power Supply	Cat. No.
1 N.C. or 2 N.C.	2 N.O.	1 N.C.	0.15...3s	Automatic	24V AC/DC, 50/60 Hz 0.85...1.1 x rated voltage	440R-S23173
			0.5...10s			440R-S23174
			1.5...30s			440R-S23175

## Approximate Dimensions

Dimensions are shown in mm (in.). Dimensions are not intended to be used for installation purposes.

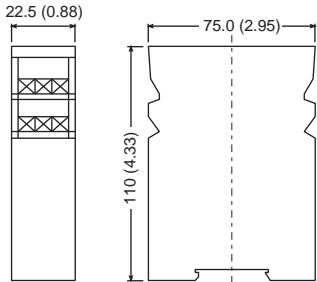

## Block Diagram

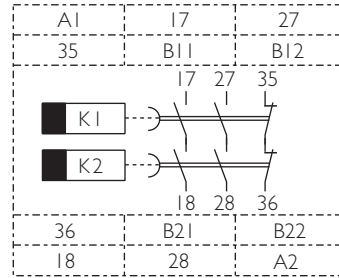

## Typical Wiring Diagrams

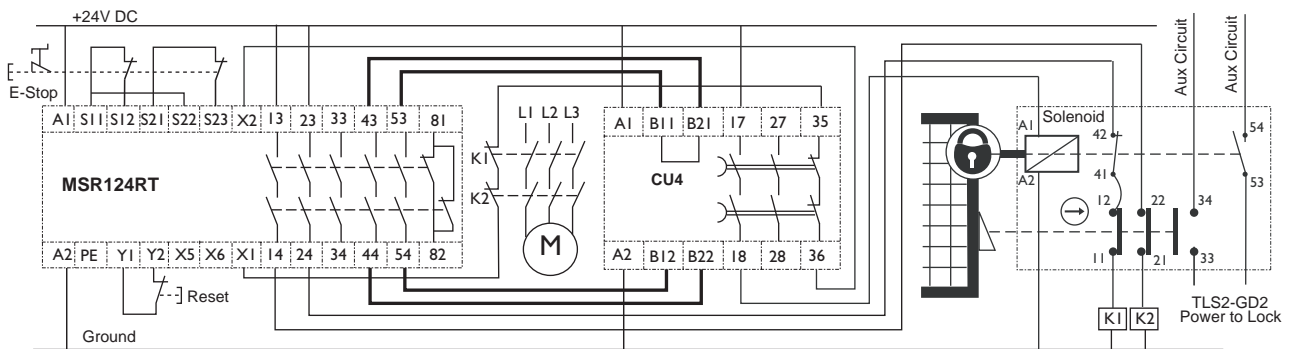

Dual Channel Wiring to CU4 Inputs

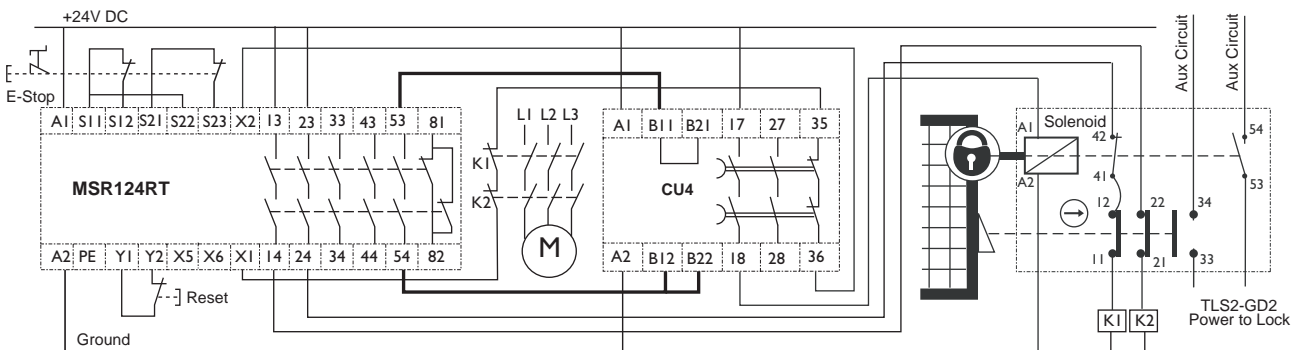

Single Channel Wiring to CU4 Inputs

# Single-Function Safety Relays with Delayed Outputs

## MSR38D/DP



Housing with removable terminals shown.

### Description

The Minotaur MSR38D/DP is a microprocessor-based, monitoring safety relay, with delayed, safety-rated, solid-state outputs.

The inputs of the MSR38D/DP are the same as the MSR30. They can be connected to gate interlocks, e-stop devices or four-wire safety mats. The gate interlocks and e-stops can be either single channel or dual channel normally-closed circuits.

The reset capability of the MSR38D/DP allows it to set up for monitored manual or automatic/manual reset.

The outputs include two delayed normally-open safety rated outputs that can be connected to loads up to 2 A at 24V DC. These outputs can be used to send a safety stop signal to a machine or manufacturing system. The delay is accomplished by the configuration of jumpers on the terminals. The delay can be easily adjusted by reconfiguring the jumpers.

The MSR38D/DP also has one solid-state normally-closed auxiliary output, which must only be used to indicate the status of the MSR38D/DP. The auxiliary output responds immediately to the change in input status; it is not delayed.

### Features

- Category 4 per EN 954-1
- Stop Category 0 or 1
- Two delayed solid-state safety outputs
- One solid-state auxiliary output
- One N.C., two N.C. or safety mat input
- Monitored manual or automatic/manual reset

### LED Indicators

Green	Power (Pwr)
Green	K1 Closed
Green	K2 Closed

### Wiring Terminations

S11 & S21	Pulse train output
S12 & S22	Input contacts
A1 - S34	Reset switch
S11 - S34	Automatic reset, start-up test disabled
S21 - S34	Automatic reset, start-up test enabled
A1 - Y2	Monitoring circuit
A1 - Y41	Cross-fault monitoring disabled

### Specifications

Safety Ratings	
Standards	EN 954-1, ISO 13849-1, IEC/EN 60204-1, ANSI B11.19, AS4024.1
Safety Classification	Cat. 4 per EN 954-1 (ISO 13849-1), SIL CL3 per EN IEC 62061, PLe per ISO 13849-1
Functional Safety Data *	PFH <sub>D</sub> : < 9.2 x 10 <sup>-10</sup> MTTFD: > 631 years Note: For up-to-date information, visit <a href="http://www.ab.com/Safety/">http://www.ab.com/Safety/</a>
Certifications	CE Marked for all applicable directives, cULus, c-Tick, and TÜV
Power Supply	
Input Power Entry	24V DC SELV
Power Consumption	3 W
Inputs	
Safety Inputs	1 N.C. or 2 N.C. or SM
Input Resistance, Max.	200 Ω
Reset	Auto./Manual or Monitored Manual
Power On Delay/Recovery Time	3 seconds/20 ms
Response Time	15 ms
Outputs	
Safety Contacts	2 N.O. SS, 2 A @ 24V DC
Auxiliary Contacts	1 N.O. SS, 50 mA @ 24V DC
Fuses, Output	External 6 A slow blow or 10 A fast acting
Power LED Diagnostics	3 s Blink: Initialization Constant: Normal Operation 2 Blinks: Configuration change during operation 4 Blinks: Solid state output switch fault 5 Blinks: Reset switch closed after reset Continuous blinking: Internal fault
Environmental and Physical Characteristics	
Enclosure Type Rating/Terminal Protection	IP40 (NEMA 1), DIN 0470/ IP20, DIN 0470
Operating Temperature [C (F)]	-5...+55 ° (23...131 °)
Vibration	10...55 Hz, 0.35 mm
Shock	10 g, 16 ms, 100 shocks
Mounting	35 mm DIN Rail
Weight [g (lbs)]	130 (0.287)
Conductor Size, Max.	0.2...2.5 mm <sup>2</sup> (24...14 AWG)

\* Usable for ISO 13849-1:2006 and IEC 62061. Data is based on the following assumptions:  
 - Mission time/Proof test interval of 20 years

# Logic Single-Function Safety Relays with Delayed Outputs MSR38D/DP

## Product Selection

Inputs	Delayed Safety Outputs	Instantaneous Auxiliary Outputs	Terminals		Reset Type	Power Supply	Cat. No.
			Fixed	Removable			
1 N.C., 2 N.C., Safety Mat	2 N.O. Solid State	1 N.O. Solid State	Fixed		Auto./Manual or Monitored Manual	24V DC SELV	440R-M23203
			Removable				440R-M23204

## Accessories

Description	Cat. No.
Bag of 4, 4-Pin Screw Terminal Blocks	440R-A23209
Bag of 4, 4-Pin Spring Clamp Terminal Blocks	440R-A23228

## Approximate Dimensions

Dimensions are shown in mm (in.). Dimensions are not intended to be used for installation purposes.

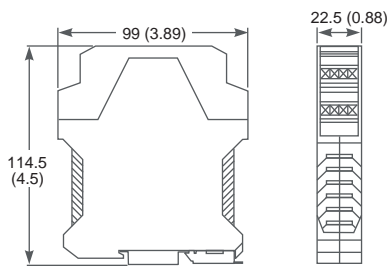

## Block Diagram

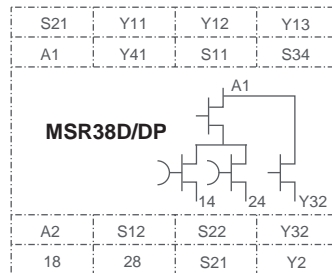

## Typical Wiring Diagrams

See MSR30 on 5-16 for additional input wiring configurations.

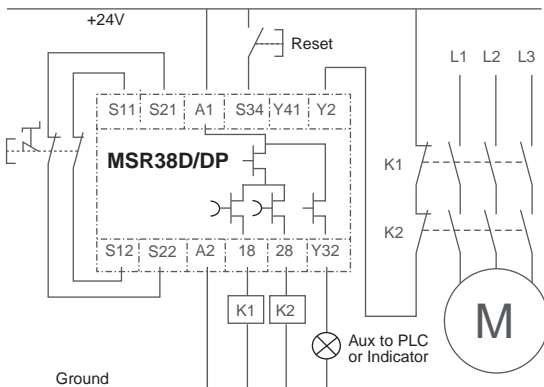

**Dual Channel E-Stop, Dual Channel Delayed Outputs, Monitored Manual Reset, Output Monitoring**

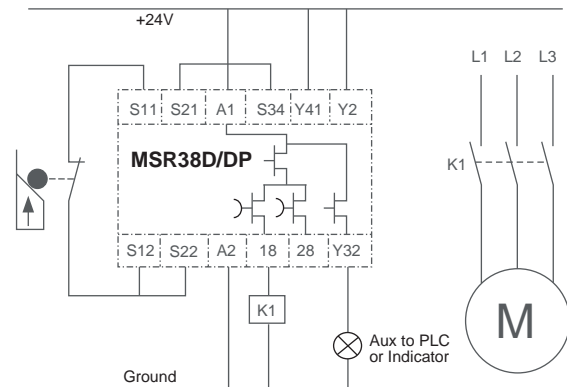

**Single Channel Gate Interlock, Single Channel Delayed Output, Automatic Reset, No Output Monitoring**

Apply jumpers (links) on the terminals identified to achieve the desired off delay.

Delay(s)	Y11	Y12	Y13	Delay(s)	Y11	Y12	Y13	Delay(s)	Y11	Y12	Y13
0	—	—	—	8	S21	S11	—	50	—	S21	S21
0.5	S11	—	—	10	—	S11	S21	60	S11	S11	S11
1	—	S11	—	12	S21	—	S11	80	S11	S11	S21
1.5	—	—	S11	15	—	S21	S11	100	S11	S21	S11
2	S21	—	—	18	S11	S11	—	120	S11	S21	S21
3	—	S21	—	21	S11	—	S11	160	S21	S11	S11
4	—	—	S21	26	—	S11	S11	200	S21	S11	S21
5	S11	S21	—	30	S21	S21	—	250	S21	S21	S11
6	S11	—	S21	40	S21	—	S21	300	S21	S21	S21

# Single-Function Safety Relays with Delayed Outputs

## MSR138DP



### Description

The MSR138DP can be connected in 3 different input wiring configurations: 1 normally closed, 2 normally closed, or 2 OSSD. When connected in the two normally closed fashion, the MSR138DP checks for cross faults across the two inputs. When connected to light curtains, the light curtain must perform the cross-fault detection.

The MSR138DP has output monitoring that can accommodate either automatic/manual reset or a monitored manual reset. When configured with automatic/manual reset (jumpers on X1-X2 and X3-X4), the MSR138DP can have the reset terminals S33-S34 jumpered or can be converted to an unmonitored manual reset by adding a normally open switch in the monitoring loop (S33-S34). When configured to monitored manual reset, the MSR138DP checks the output monitoring circuit through the manual application of the reset switch. The unit cannot be reset until the timing function has completed.

The outputs of the MSR138DP include two normally open immediate safety outputs and three normally open delayed safety outputs. The outputs of the MSR138.1DP include two normally open immediate safety rated outputs, two normally open delayed safety outputs and one normally closed delayed safety output. The safety outputs have independent and redundant internal contacts to support the safety function. If a reset request is made during the time cycle, it will cause a lockout condition. Cycle inputs after timing has completed and reset after the delay time has expired to clear lockout. Connecting contacts 55-56 of the MSR138.1DP in series to Y1-Y2 can avoid this lockout.

A normally closed timer reset switch can be added to force the delayed contacts open prior to the completion of the timing cycle.

### Features

- Category 4/3 per EN 954-1
- Stop category 0 and 1
- Light curtain, E-stop, safety gate inputs
- Two immediate safety outputs
- Delayed outputs: 3 N.O. safety or 2 N.C. safety and 1 N.C. aux.
- Cross fault monitoring
- Monitored or automatic reset
- Removable terminals

### LED Indicators

Green	Power—Illuminates when power on
Green	Start—Illuminates when S33-S34 is closed
Green	CH1 IN—Illuminates when channel 1 input is closed
Green	CH2 IN—Illuminates when channel 2 input is closed
Green	CH1—Illuminates when K1 is closed
Green	CH2—Illuminates when K2 is closed
Green	CHT1—Illuminates during timing period
Green	CHT2—Illuminates during timing period

### Specifications

Safety Ratings		
Standards	EN 954-1, ISO 13849-1, IEC/EN 60204-1, IEC 60947-4-1, IEC 60947-5-1, ANSI B11.19, AS4024.1	
Safety Classification	Cat. 4 per EN 954-1 (ISO 13849-1), SIL CL3 per EN IEC 62061, PLe per ISO 13849-1	
Functional Safety Data * <b>Note:</b> For up-to-date information, visit <a href="http://www.ab.com/Safety/">http://www.ab.com/Safety/</a>	PFHD: < 2.38 x 10 <sup>-9</sup> MTTFd: > 195 years Suitable for performance levels PLe (according to ISO 13849-1:2006) and for use in SIL3 systems (according to IEC 62061) depending on the architecture and application characteristics	
Certifications	CE Marked for all applicable directives, cULus, c-Tick, and TÜV	
Power Supply		
Input Power Entry	24V AC/DC, 115V AC or 230V AC	
Power Consumption	4 W	
Inputs		
Safety Inputs	1 N.C., 2 N.C. or LC	
Input Simultaneity	Infinite	
Input Resistance, Max.	135 Ω	
Reset	Auto./Manual or Monitored Manual	
Power On Delay/ Recovery Time	1 second/100 ms	
Response Time	15 ms	
Outputs		
Safety Contacts	2 N.O.	
Auxiliary Contacts	Delayed 3/2 N.O.	
Thermal Current <sub>I<sub>th</sub></sub>	5 x 2.5 A or 3 x 3.5 A nonswitching	
Rated Impulse withstand Voltage	2500V	
Switching Current @ Voltage, Min.	10 mA @ 10V	
Fuses, Output	External 6 A slow blow or 10 A fast acting (With surge suppression) 250V AC/6 A/1500VA cosφ = 1...0.1 M 250V AC/2.5 A/625VA cosφ = 1...0.5 M 250V AC/1.5 A/375VA cosφ = 0.35...0.3 M 250V AC/5 A/1250VA cosφ = 0.6...0.1 M 24V DC/2 A/48 W = 1 M 10V DC/0.01 A/0.1 W = 2 M	
Electrical Life (Operations)		
Mechanical Life	2,000,000 cycles	
Utilization Category		
Resistive: AC-1	7 A@ 250V AC	
Resistive: DC-1	7 A/24V DC	
Inductive: AC-15	6 A@ 250V AC	6 A @ 125V AC
Inductive: DC-13	3 A/24V DC	6 A/24V DC @ 6 ops/min
UL	B300, 5 A/250V AC, 24V DC	
Environmental and Physical Characteristics		
Enclosure Type Rating/ Terminal Protection	IP40 (NEMA 1)/ IP20	
Operating Temperature [C (F)]	-5...+55 ° (23...131 °)	
Vibration	10...55 Hz, 0.35 mm	
Shock	10 g, 16 ms, 100 shocks	
Mounting	35 mm DIN Rail	
Weight [g (lbs)]	24V DC: 350 (0.77); 115/230V AC: 490 (1.08)	
Conductor Size, Max.	0.2...4 mm <sup>2</sup> (24...12 AWG)	

\* Usable for ISO 13849-1:2006 and IEC 62061. Data is based on the following assumptions:  
 - Mission time/Proof test interval of 20 years  
 - Functional test at least once within six-month period

# Logic Single-Function Safety Relays with Delayed Outputs MSR138DP

## Product Selection

Inputs	Safety Outputs	Delayed Safety Outputs	Delayed Auxiliary Outputs	Time Delay	Terminals	Reset Type	Power Supply	Cat. No.			
1 N.C., 2 N.C., Light Curtain	2 N.O.*	3 N.O.* (MSR138DP)	—	1.0 seconds, fixed	Removable	Auto./Manual or Monitored Manual	115V AC	440R-M23080			
				0.15...3 s	Spring Clamp		24V AC/DC	440R-M23143 440R-M23143S			
					Removable		115V AC	440R-M23141			
				0.15...3 seconds	Spring Clamp		230V AC	440R-M23140			
					Removable		24V AC/DC	440R-M23147 440R-M23147S			
				0.5...10 s	Spring Clamp		115V AC	440R-M23145			
					Removable		230V AC	440R-M23144			
				0.5...10 seconds	Spring Clamp		24V AC/DC	440R-M23151			
					Removable		115V AC	440R-M23149			
		1.5...30 seconds	Spring Clamp	230V AC	440R-M23148						
			Removable	24V AC/DC	440R-M23084						
		0.15...3 seconds	1 N.C.	2 N.O.* (MSR138.1DP)	1 N.C.		0.15...3 seconds	Removable	Auto./Manual or Monitored Manual	115V AC	440R-M23082
										230V AC	440R-M23081
										24V AC/DC	440R-M23088
										115V AC	440R-M23086
										230V AC	440R-M23085
										24V AC/DC	440R-M23092
										115V AC	440R-M23090
230V AC	440R-M23089										
24V AC/DC	440R-M23092										

\* Instantaneous safety outputs Cat. 4  
\* Delayed safety outputs are Cat. 3

## Accessories

Description	Cat. No.
Bag of 4, 4-Pin Screw Terminal Blocks	440R-A23209
Bag of 4, 4-Pin Spring Clamp Terminal Blocks	440R-A23228

## Approximate Dimensions

Dimensions are shown in mm (in.).  
Dimensions are not intended to be used  
for installation purposes.

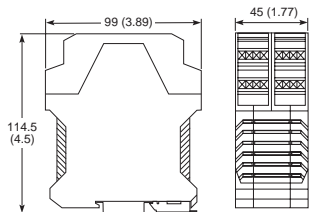

## Block Diagram

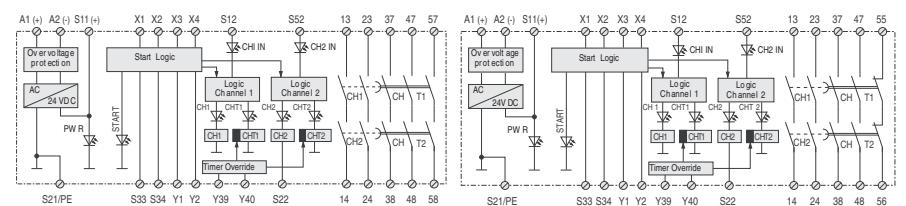

MSR138DP

MSR138.1DP

In applications with 24V AC supply: terminal S21 must not be connected to PE.

## Typical Wiring Diagrams

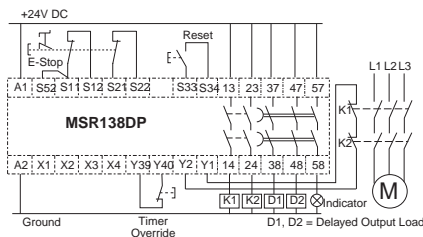

24V DC Supply Dual Channel E-Stop,  
Monitored Manual Reset, Monitored Output

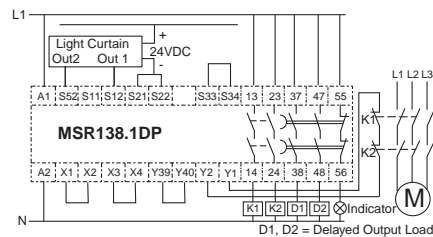

115/230V AC Supply, 24V DC Light Curtain,  
Automatic Reset, Monitored Output

5-Safety Relays

## Single-Function Safety Relays with Delayed Outputs

## MSR178DP



## Description

The MSR178DP is a multi-function time-delay relay for use in safety circuits. It can be configured by the user to perform on-delay, off-delay or single-pulse modes. It is used for applications such as delayed unlocking of safety gates, delayed de-energizing of variable speed controlled motors, or jogging (single pulse) in teaching or setup mode.

The MSR178DP can be used e.g. in conjunction with a power to release or power to lock guard locking switch to time out high inertia machines with significant run down in potentially dangerous equipment. The single-pulse mode enables implementation of two-hand control by use of two normally open contacts. It also can be used as a preset time limited mute dependent bypass in order to clear a blockage in the muting sensor area.

The operating function is selected by external jumpers to Y21 and Y22. The delay time is selected by a combination of external jumpers to Y31 and Y32 and the potentiometer located on the front face.

The input to the MSR178DP can be connected in five different configurations: one normally closed, two normally closed, one normally open, two normally open, or two PNP connections from a light curtain. The normally closed connections are used for off-delay timing. The normally open inputs are used for on-delay timing and the single-pulse function. To generate the single pulse both inputs must be closed within 0.5 seconds. Thus a two-hand control arrangement in accordance with EN 574 Cat. IIIA can be used to trigger the single pulse.

The MSR178DP has three normally open redundant safety outputs. The two normally closed outputs can be connected in series to achieve redundant safety or connected in parallel for auxiliary signaling. External devices can be monitored by the Y11 terminal. Power to the MSR178DP can be either 24V AC/DC (24V/GND terminals) or 115V AC (A3/A2 terminals), or 230V AC (A1/A2 terminals).

The MSR178DP can be used as a standalone control module or in combination with an MSR safety relay to combine instant and delayed safety outputs, as needed.

## Features

- Category 4 per EN 954-1
- SIL3 per IEC 61508
- Stop category 1
- On-/off-delayed, or single-pulse (one shot) operation
- Four time ranges up to 30 mins.
- Pulsed or static input monitoring
- Three N.O. safety outputs
- One N.C. safety or two N.C. auxiliary outputs
- Eight diagnostic LEDs
- Automatic reset
- Removable terminals

## Specifications

Safety Ratings	
Standards	EN 954-1, IEC 61508, EN IEC 62061, ISO 13849-1, IEC/EN 60204-1, IEC 60947-5-1, EN 61812-1, AS 4024.1, ISOTR 12100, B11.19
Safety Classification	Cat. 4 per EN 954-1 (ISO 13849-1), SIL CL3 per EN IEC 62061, PLe per ISO 13849-1
Functional Safety Data *	PFH <sub>D</sub> : < 2.74 x 10 <sup>-9</sup> MTTF <sub>d</sub> : > 285 years Suitable for performance levels Ple (according to ISO 13849-1:2006) and for use in SIL3 systems (according to IEC 62061) depending on the architecture and application characteristics
Note:	For up-to-date information, visit <a href="http://www.ab.com/Safety/">http://www.ab.com/Safety/</a>
Certifications	CE Marked for all applicable directives, cULus, c-Tick, and TÜV
Power Supply	
Input Power Entry	24V AC/DC, 115/230V AC 50/60 Hz
Power Consumption	4 W
Inputs	
Safety Inputs	1 or 2 N.O., 1 or 2 N.C., Light Curtain
Input Simultaneity	Infinite for On-/Off-delay, 0.5 s for single pulse function
Input Resistance, Max.	900 Ω
Reset	Automatic
Power On Delay/Recovery Time	500 ms/300 ms single pulse only
Response Time	<±0.5% (at constant temp)
Outputs	
Safety Contacts	3 N.O.
Auxiliary Contacts	2 N.C.
Thermal Current/ <i>I<sub>th</sub></i>	6 A
Rated Impulse withstand Voltage	2500V
Switching Current @ Voltage, Min.	10 mA @ 10V DC
Fuses, Output	External 6 A slow blow or 10 A quick blow
Electrical Life (Operations)	230V AC/4 A/880VA cosφ = 0.35...0.1 M 230V AC/1.7 A/375VA cosφ = 0.6...0.5 M 30V DC/2 A/60 W = 1 M 10V DC/0.01 A/0.1 W = 2 M
Mechanical Life	2,000,000 operations
Utilization Category	
Inductive: AC-15	6 A/250V AC
Inductive: DC-13	3 A/24V DC
UL:	B300, 6 A/250V AC, 3 A/24V DC
Environmental and Physical Characteristics	
Enclosure Type Rating/ Terminal Protection	IP40 (NEMA 1), DIN VDE 0470-1/ IP20
Operating Temperature [C (F)]	-5...+55 ° (14...131 °)
Vibration	10...55 Hz, 0.35 mm
Shock	10 g, 16 ms, 100 shocks
Mounting	35 mm DIN Rail
Weight [g (lbs)]	325 (0.72)
Conductor Size, Max.	0.2...4 mm <sup>2</sup> (24... 12 AWG)

\* Usable for ISO 13849-1:2006 and IEC 62061. Data is based on the following assumptions:  
- Mission time/Proof test interval of 20 years  
- Functional test at least once within six-month period

# Logic Single-Function Safety Relays with Delayed Outputs MSR178DP

## Product Selection

Inputs	Safety Outputs	Auxiliary Outputs	Terminals	Reset Type	Power Supply	Cat. No.
1 or 2 N.O., 1 or 2 N.C., Light Curtain, Two-Hand Control, Enabling Switch	3 N.O.	2 N.C.	Removable	Automatic	24V AC/DC, 115V AC or 230V AC	440R-M23227

## Accessories

Description	Cat. No.
Bag of 4, 3-Pin Screw Terminal Blocks	440R-A23210
Bag of 4, 3-Pin Spring Clamp Terminal Blocks	440R-A23229

## LED Indicators

PWR: Green	Power on
Flashing Green/Red	Failure
CH1/2 IN: Static Green	Input closed
Flashing Green	Time lapse
CHT1: Green	Output CH1 Active
CHT2: Green	Output CH2 Active

## Approximate Dimensions

Dimensions are shown in mm (in.). Dimensions are not intended to be used for installation purposes.

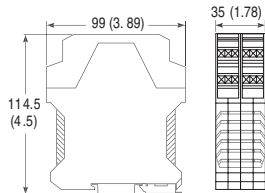

## Block Diagram

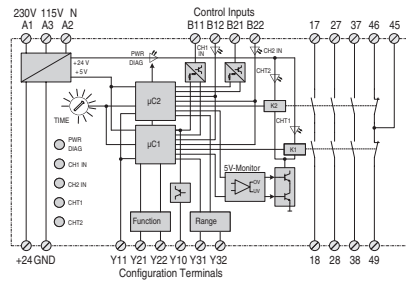

## Typical Wiring Diagrams

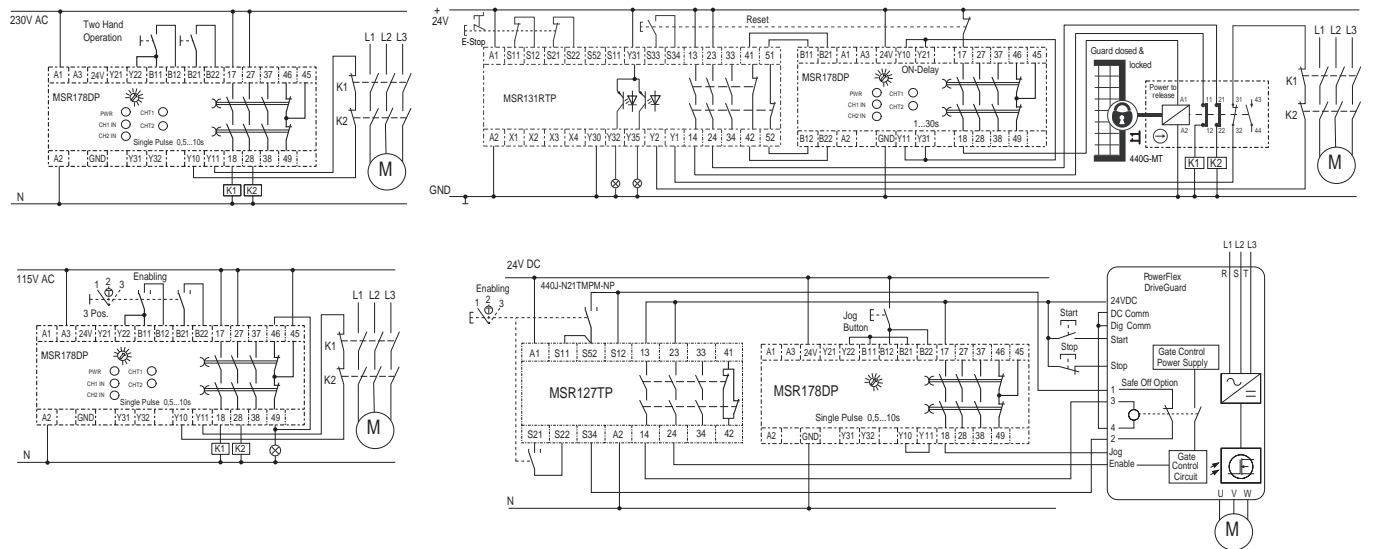

# Single-Function Safety Relays with Delayed Outputs

## MSR178DP

### Typical Wiring Diagrams (continued)

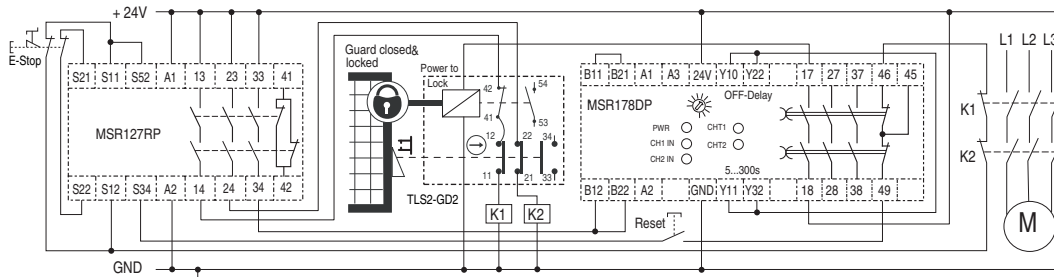

MSR178DP generates OFF-delayed solenoid release after E-Stop on MSR127

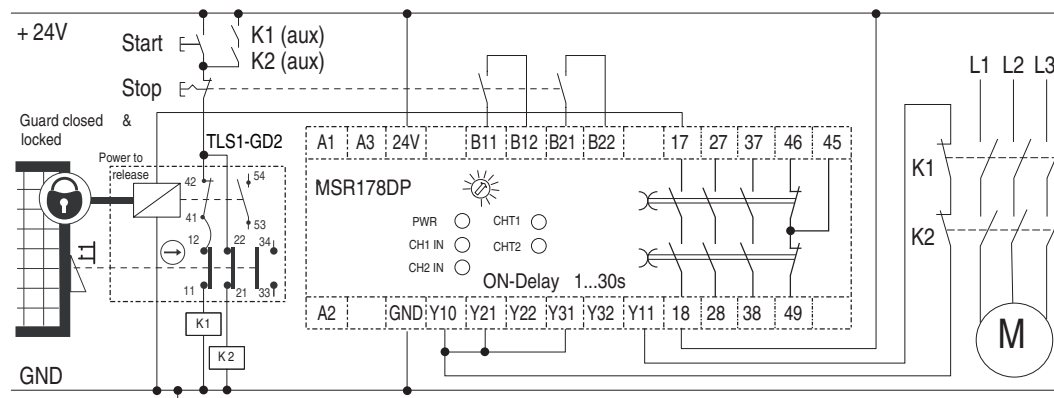

MSR178DP ON-delayed unlocking the Gate after maintained stop switch pressed

### Jumper Configuration

Operating Function		
Y10...Y21 Y10...Y22 B11...Y22		ON Delay OFF Delay Single Pulse
Time Range		
— Y10...Y31 Y10...Y32 Y10...Y31...Y32		0.5...10 s 1...30 s 5...300 s 1...30 min
Cross Fault Detection on Inputs		
— B11...B21		Enabled Disabled
Feedback Loop		
Y10...Y11		Close before reset

**Time Function Diagrams**

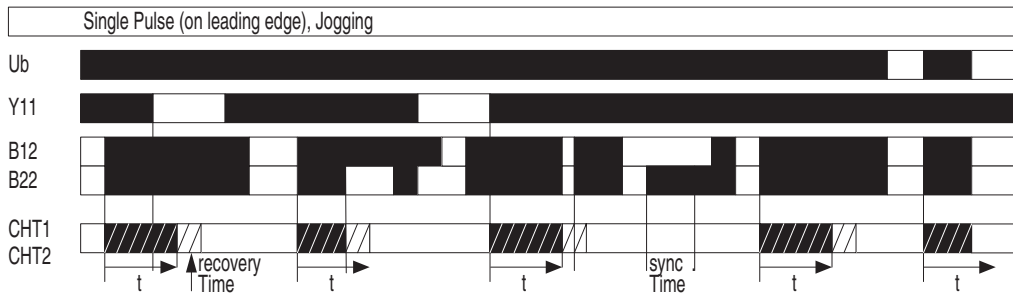
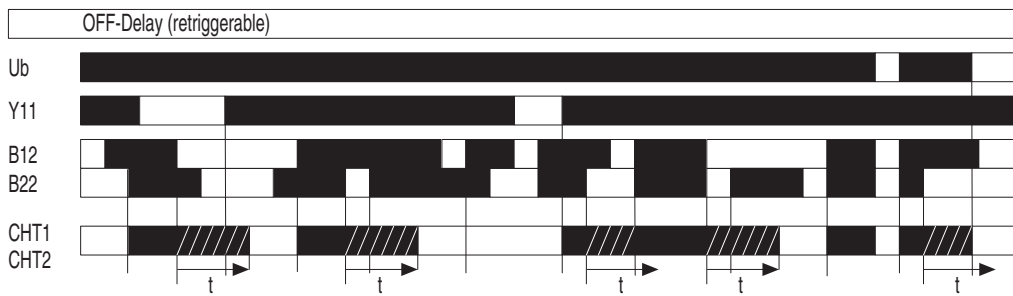
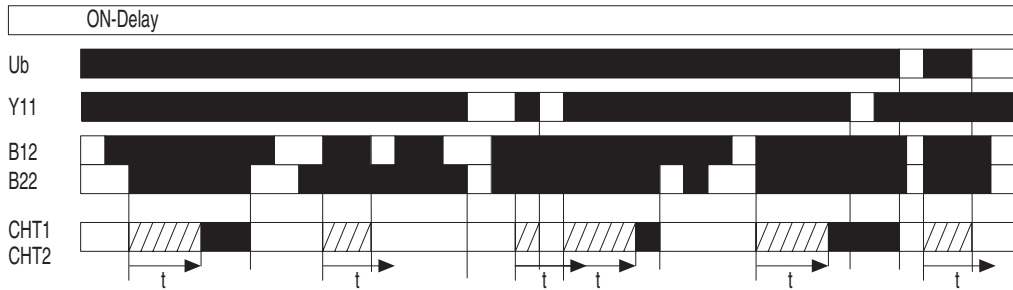
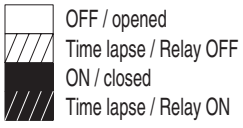

## Specialty Safety Relays

### MSR35H/HP Two-Hand Control



Housing with removable terminals shown.

#### Description

The Minotaur MSR35H/HP is a microprocessor-based, two-hand control monitoring safety relay, with safety-rated, solid-state outputs.

The input of the MSR35H/HP accepts two switches, each containing one normally open and one normally closed. Both switches must be actuated within 0.5 seconds of each other.

The MSR35 can alternatively be wired with two switches with normally open contacts to a Category IIIA application per EN 574.

The reset capability of the MSR35H/HP allows it to be set up for manual or automatic reset.

The outputs include two normally-open safety-rated outputs that can be connected to loads up to 2 A at 24V DC. These outputs can be used to send a safety stop signal to a machine or manufacturing system.

The MSR35H/HP also has one solid-state normally-closed auxiliary output, which must only be used to indicate the status of the MSR35H/HP.

#### Features

- Category 4 per EN 954-1
- Category IIIC or IIIA per EN 574
- Two solid-state safety outputs
- One solid-state auxiliary output
- Two-hand control input

#### LED Indicators

Green	Power (Pwr)
Green	K1 Energized
Green	K2 Energized

#### Specifications

Safety Ratings	
Standards	EN 954-1, ISO 13849-1, EN 574, IEC/EN 60204-1, ANSI B11.19, AS4024.1
Safety Classification	Cat. 4 per EN 954-1 (ISO 13849-1), SIL CL3 per EN IEC 62061, PLe per ISO 13849-1
Functional Safety Data * <b>Note:</b> For up-to-date information, visit <a href="http://www.ab.com/Safety/">http://www.ab.com/Safety/</a>	PFH <sub>D</sub> : < 9.2 x 10 <sup>-10</sup> MTTF <sub>D</sub> : > 631 years Suitable for performance levels Pl <sub>e</sub> (according to ISO 13849-1:2006) and for use in SIL3 systems (according to IEC 62061) depending on the architecture and application characteristics
Certifications	CE Marked for all applicable directives, cULus, c-Tick, and TÜV
Power Supply	
Input Power Entry	24V DC SELV
Power Consumption	3 W
Inputs	
Safety Inputs	1 N.C. & 1 N.O. or 2 N.O.
Input Simultaneity	0.5 s
Input Resistance, Max.	200 Ω
Reset	Automatic
Power On Delay/Recovery Time	3 seconds/20 ms
Response Time	15 ms
Outputs	
Safety Contacts	2 N.O., 2 A @ 24V DC
Auxiliary Contacts	1 N.O., 50 mA @ 24V DC
Fuses, Output	External 6 A slow blow or 10 A fast acting
Power LED Diagnostics	3 s Blink: Initialization Constant: Normal Operation 2 Blinks: Configuration change during operation 4 Blinks: Solid state output switch fault Continuous blinking: Internal fault
Environmental and Physical Characteristics	
Enclosure Type Rating/Terminal Protection	IP40 (NEMA 1), DIN 0470/ IP20, DIN 0470
Operating Temperature [C (F)]	-5...+55 ° (23...131 °)
Vibration	10...55 Hz, 0.35 mm
Shock	10 g, 16 ms, 100 shocks
Mounting	35 mm DIN Rail
Weight [g (lbs)]	130 (0.287)
Conductor Size, Max.	0.2...2.5 mm <sup>2</sup> (24...14 AWG)

\* Usable for ISO 13849-1:2006 and IEC 62061. Data is based on the following assumptions:  
- Mission time/Proof test interval of 20 years

**Product Selection**

Inputs	Safety Outputs	Auxiliary Outputs	Terminals	Reset Type	Power Supply	Cat. No.
2 x 1 N.C. + 1 N.O. (Two-Hand Control) or 2 x N.O.	2 N.O. Solid State Safety; 1 N.O. Solid State Auxiliary	1 N.O. Solid State	Fixed	Automatic	24V DC SELV	440R-D23201
			Removable			440R-D23202

**Accessories**

Description	Cat. No.
Bag of 4, 4-Pin Screw Terminal Blocks	440R-A23209
Bag of 4, 4-Pin Spring Clamp Terminal Blocks	440R-A23228

**Approximate Dimensions**

Dimensions are shown in mm (in.). Dimensions are not intended to be used for installation purposes.

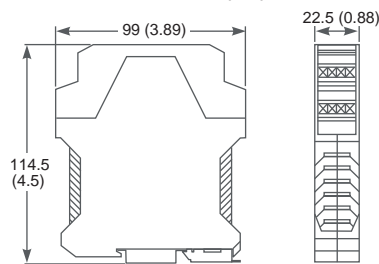

**Block Diagram**

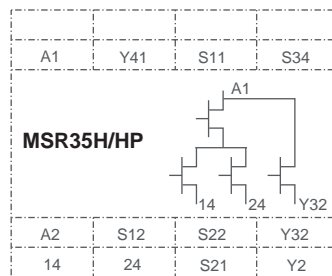

**Typical Wiring Diagrams**

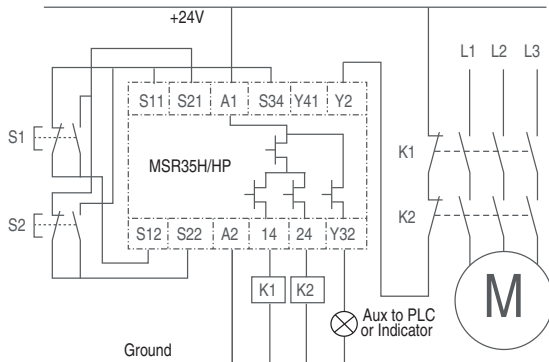

Switch connection to pulsed signals from S11 and S21, connection between S11 and S34.

**Two-Hand Control, Dual Channel Outputs, Output Monitoring**

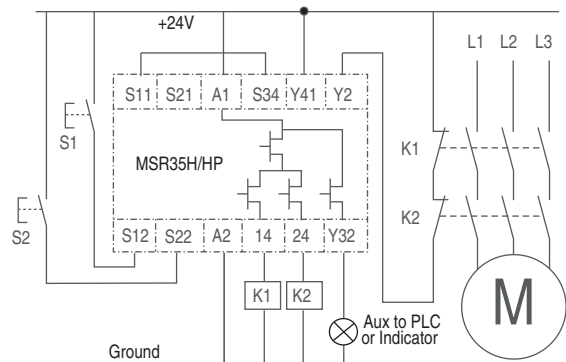

Switch connection direct to 24V DC supply, Y41 to +24V DC, connection between S11 and S34.

**Two-Hand Control, Dual Channel Outputs, Output Monitoring**

**Note:** EN 574 IIIC when wired with two sets of N.O./N.C., EN 574 IIIA when wired with two sets of N.O. contacts.

**Note:** Connect Y41 to +24V to disable pulse testing.

## Specialty Safety Relays

### MSR125H/HP Two-Hand Control



#### Description

The Allen-Bradley Guardmaster Minotaur MSR125H/HP is a logic unit for monitoring and interfacing two-hand control devices with a safety-related circuit. The MSR125H/HP is for use with mechanical switches and the Rockwell Automation Bulletin 800Z Zero-Force Touch Buttons.

The MSR125H/HP has two normally open safety outputs. The safety outputs have independent and redundant internal contacts to support the safety function.

The MSR125H/HP requires the two switches to be operated within 0.5 seconds of each other and will only authorize the ON state while both switches are held down. If one of the switches is released, the output goes to the OFF state and the machine cannot be restarted until both buttons are released and then operated simultaneously.

The MSR125H/HP conforms to EN 574 Category IIIC, which gives specific requirements for two-hand control units and logic devices.

The MSR125H has fixed terminals and the MSR125HP has removable terminals.

#### Features

- Category 4 per EN 954-1
- Safety category IIIC per EN 574
- Two-hand control unit
- Two N.O. safety outputs
- Fixed or removable terminals
- 22.5 mm wide housing

#### LED Indicators

Green	Power on
Green	CH1 Output Active
Green	CH2 Output Active

#### Specifications

Safety Ratings		
Standards	EN 574, EN 954-1, ISO 13849-1, IEC/EN 60204-1, IEC 60947-4-1, IEC 60947-5-1, ANSI B11.19, AS 4024.1	
Safety Classification	Cat. 4 per EN 954-1 (ISO 13849-1), SIL CL3 per EN IEC 62061, PLe per ISO 13849-1	
Functional Safety Data * <b>Note:</b> For up-to-date information, visit <a href="http://www.ab.com/Safety/">http://www.ab.com/Safety/</a>	PFH <sub>D</sub> : < 1.44 x 10 <sup>-9</sup> MTTF <sub>d</sub> : > 385 years Suitable for performance levels PLe (according to ISO 13849-1:2006) and for use in SIL3 systems (according to IEC 62061) depending on the architecture and application characteristics	
Certifications	CE Marked for all applicable directives, cULus, c-Tick, and BG	
Power Supply		
Input Power Entry	24V DC, 24V AC, 115V AC, 230V AC	
Power Consumption	2 W	
Inputs		
Safety Inputs	1 N.C. + 1 N.O.	
Input Simultaneity	<0.5 sec	
Input Resistance, Max.	40 Ω	
Reset	Automatic	
Power On Delay/Recovery Time	1 second/500 ms	
Response Time	20 ms	
Outputs		
Safety Contacts	2 N.O.	
Thermal Current/ <i>I<sub>th</sub></i>	1 x 6 A or 2 x 4 A nonswitching	
Rated Impulse withstand Voltage	2500V	
Switching Current @ Voltage, Min.	10 mA/10V	
Fuses, Output	External 6 A slow blow or 10 A fast acting	
Electrical Life (Operations)	(With surge suppression) 250V AC/6 A/1500VA cosφ = 0.35...0.1 M 250V AC/2.5 A/625VA cosφ = 0.6...0.5 M 250V AC/1.5 A/375VA cosφ = 0.35...0.3 M 250V AC/5 A/1250VA cosφ = 0.6...0.1 M 24V DC/2 A/48 W = 1 M 10V DC/0.01 A/0.1 W = 2 M	
Mechanical Life	2,000,000 operations	
Utilization Category		
Resistive: AC-1	8 A @ 250V AC	
Resistive: DC-1	6 A/24V DC	
Inductive: AC-15	6 A @ 250V AC	6 A @ 125V AC
Inductive: DC-13	3 A/24V DC	6 A/24V DC @ 6 ops/min
Resistive UL:	B300, R300, 8 A/250V AC, 6 A/24V DC, 30V DC Resistive	
Environmental and Physical Characteristics		
Enclosure Type Rating/Terminal Protection	IP40 (NEMA 1), DIN 0470/ IP20, DIN 0470	
Operating Temperature [C (F)]	-5...+55 ° (23...131 °)	
Vibration	10...55 Hz, 0.35 mm	
Shock	10 g, 16 ms, 100 shocks	
Mounting	35 mm DIN Rail	
Weight [g (lbs)]	24V DC: 210 (0.46); 115/230V AC: 260 (0.57)	
Conductor Size, Max.	0.2...4 mm <sup>2</sup> (24...12 AWG)	

\* Usable for ISO 13849-1:2006 and IEC 62061. Data is based on the following assumptions:  
- Mission time/Proof test interval of 20 years

**Product Selection**

Inputs	Button Type	Safety Outputs	Terminals	Reset Type	Power Supply	Cat. No.
1 N.C. + 1 N.O. (Two-Hand Control)	Mechanical or Bulletin 800Z	2 N.O.	Removable (MSR125HP)	Automatic	24V DC	<b>440R-D23171</b>
					24V AC	440R-D23170
					115V AC	440R-D23169
			230V AC		440R-D23168	
			24V DC		440R-D23166	
			115V AC		440R-D23164	
			230V AC		440R-D23163	
			Fixed (MSR125H)			

**Accessories**

Description	Cat. No.
Bag of 4, 4-Pin Screw Terminal Blocks	440R-A23209
Bag of 4, 4-Pin Spring Clamp Terminal Blocks	440R-A23228

**Approximate Dimensions**

Dimensions are shown in mm (in.). Dimensions are not intended to be used for installation purposes.

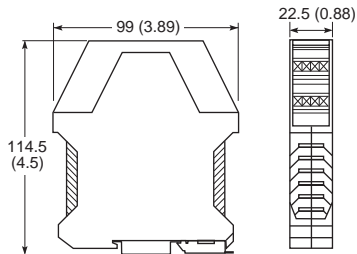

**Block Diagram**

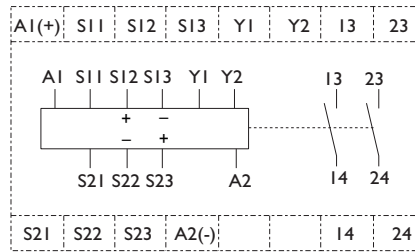

**Typical Wiring Diagrams**

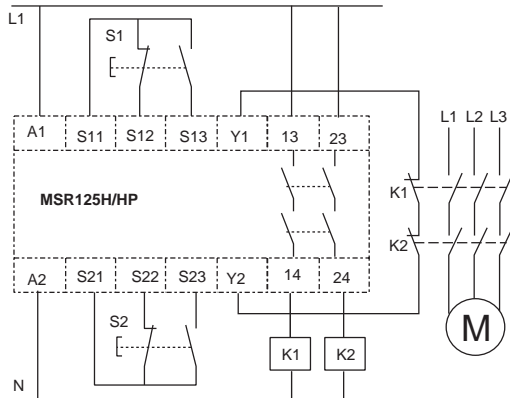

*Two-Hand Control, Dual Channel, Auto Reset,  
Output Monitoring*

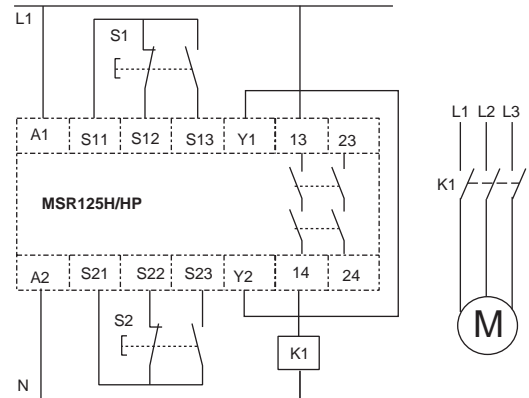

*Two-Hand Control, Dual Channel, Auto Reset,  
No Output Monitoring*

## Specialty Safety Relays

### MSR22LM Muting Light Curtain



#### Description

The MSR22LM safety monitoring relay is designed to monitor light curtains with the added features of muting and presence sensing device initiation (PSDI). It provides an output to a machine control system when the light curtain is clear. When the inputs to the MSR22LM are closed (conducting), the output relays are closed if the monitoring circuit is satisfied.

The MSR22LM has three sets of dual channel inputs. This allows it to operate in four different configurations:

1. Monitors up to three light curtains in guard only mode.
2. Monitors up to two light curtains with two muting sensors (only one curtain muted).
3. Monitor one light curtain with four muting sensors.
4. Monitors up to three light curtains with PSDI (only one curtain initiated).

The MSR22LM uses microprocessor based technology to offer a wide variety of advanced safety solutions in a small 45 mm DIN rail mounted housing. Internal selector switches provide for easy selection of up to ten different applications. Four LEDs give operational status as well as diagnostic information. Removable terminals reduce wiring and installation costs when replacement is necessary.

#### Features

- Category 4 per EN 954-1
- Stop category 0
- Light curtain muting—two or four sensors
- Presence sensing device initiation—up to three breaks
- 45 mm housing
- Removable terminals
- 24V DC supply voltage
- Start/restart interlock

#### LED Indicators

Power: Green	Ready
K1: Green	K1 Closed
If K1 alone is lit, check for short across reset button	
K2: Green	K2 Closed

#### Specifications

Safety Ratings		
Standards	EN 954-1, ISO13849-1, IEC/EN 60204-1, IEC 60947-5-1, IEC 61496-1, ANSI B11.19, AS4024.3	
Safety Classification	Cat. 4 per EN 954-1 (ISO 13849-1), SIL CL3 per EN IEC 62061, PLe per ISO 13849-1	
Functional Safety Data * <b>Note:</b> For up-to-date information, visit <a href="http://www.ab.com/Safety/">http://www.ab.com/Safety/</a>	PFH <sub>D</sub> : < See website MTTF <sub>d</sub> : > See website Suitable for performance levels PLe (according to ISO 13849-1:2006) and for use in SIL3 systems (according to IEC 62061) depending on the architecture and application characteristics	
Certifications	CE Marked for all applicable directives and BG	
Power Supply		
Input Power Entry	24V DC	
Power Consumption	4 W	
Inputs		
Safety Inputs	2 N.C. Symmetric or Asymmetric, Switch Selectable	
Input Simultaneity	0.5 seconds	
Input Resistance, Max.	S12-S14: 300 Ω S21-S22: 200 Ω S33-S34: 250 Ω	
Reset	Auto./Manual	
Power On Delay Time	40 ms (Manual Reset); 200 ms (Auto Reset)	
Response Time	15 ms	
Outputs		
Safety Contacts	2 N.O.	
Auxiliary Contacts	1 N.C.	
Thermal Current/ <i>I<sub>th</sub></i>	5 A nonswitching	
Switching Current @ Voltage, Min.	1 mA @ 10V	
Fuses, Output	6 A fast acting (external)	
Electrical Life (Operations)	220V AC/4 A/880VA cosφ = 0.35...0.1 M 220V AC/1.7 A/375VA cosφ = 0.6...0.5 M 30V DC/2 A/60 W = 1 M 10V DC/0.01 A/0.1 W = 2 M	
Mechanical Life	10,000,000 operations	
Utilization Category (Inductive)		
B500: AC-15	3 A @ 250V AC	3 A @ 120V AC
P300 DC-13	3 A/24V DC	
B300 AC-15	2 A @ 250V AC	2 A @ 120V AC
DC-13	2 A/24V DC	
Environmental and Physical Characteristics		
Enclosure Type Rating/ Terminal Protection	IP40 (NEMA 1), DIN 0470/ IP20, DIN 0470	
Operating Temperature [C (F)]	-15...+55 ° (5...131 °)	
Vibration	0.35 mm 10...55 Hz	
Mounting	35 mm DIN Rail	
Weight [g (lbs)]	220 (0.485)	
Conductor Size, Max.	1 x 2.5 mm <sup>2</sup> (14 AWG) stranded, 1 x 4 mm <sup>2</sup> (12 AWG) solid	

- \* Usable for ISO 13849-1:2006 and IEC 62061. Data is based on the following assumptions:  
 - Mission time/Proof test interval of 20 years  
 - Functional test at least once within six-month period

**Product Selection**

Inputs	Safety Outputs	Auxiliary Outputs	Terminals	Reset Type	Power Supply	Cat. No.
3 x 2 N.C.	2 N.O.	1 N.C.	Removable	Auto./Manual	24V DC	440R-P23071

**Accessories**

Description	Cat. No.
70 mm Tower Light Clear LED Module—Black Enclosure	855T-B24YL7
70 mm Tower Light Clear LED Module—Grey Enclosure	855T-G24YL7

**Application Details**

Disconnect power. Use a screwdriver to pop open cover to reveal internal switches.

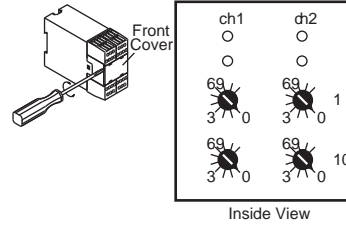

**Approximate Dimensions**

Dimensions are shown in mm (in.). Dimensions are not intended to be used for installation purposes.

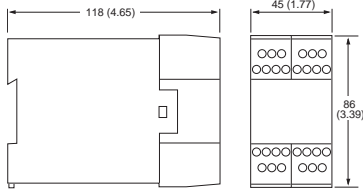

**Block Diagram**

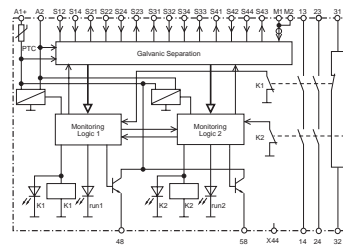

**Typical Wiring Diagrams**

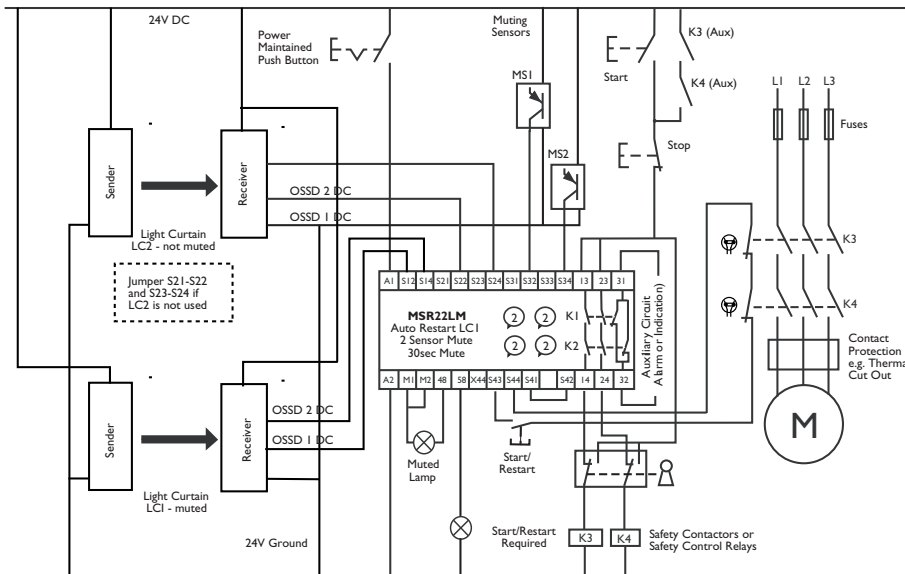

**Note:** Two light curtains with two-sensor muting and Auto Restart LC1.

# Specialty Safety Relays

## MSR22LM Muting Light Curtain

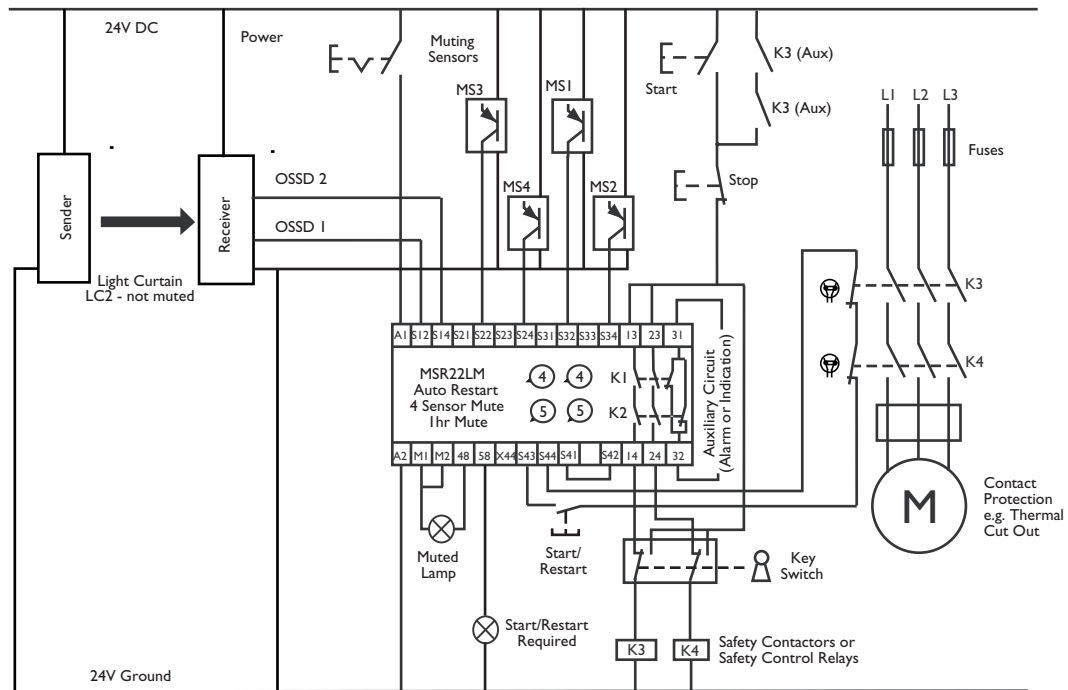

**Note:** Typical one light curtain with four-sensor muting and Auto Restart LC1.

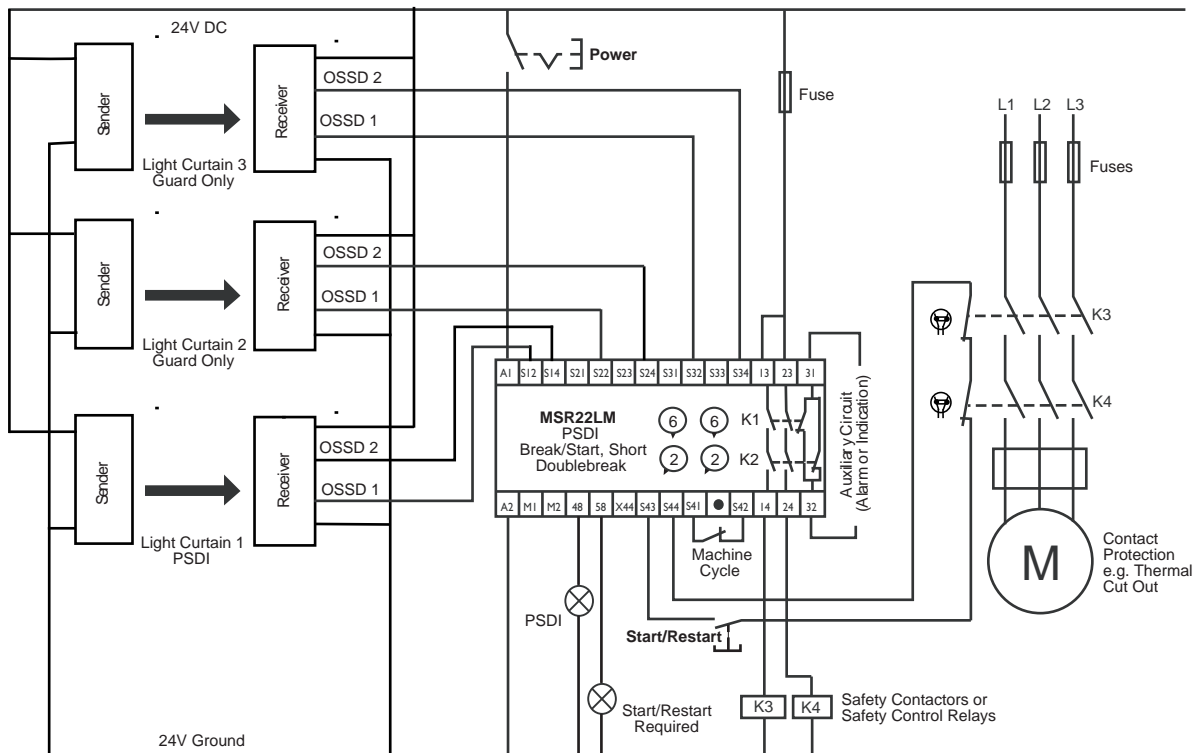

**Note:** Light curtain inputs, Presence Sensing Device Initiation (on LC1) Start/Restart Interlock, Dual Channel Output, Output Monitoring.

5-Safety Relays

**Application Details**

**MSR22LM—Shown connected to a safety light curtain.**

Multiple settings are available offering a variety of advantages. Below are the three most common settings.

**Protective Mode**

Example shows a press protected by a safety light curtain connected to the MSR22LM.

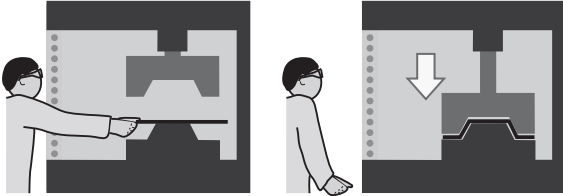

In machine operation, whenever the light curtain beams are broken the press immediately stops to help avoid danger to the operator. Once the beams are cleared the machine can then be started.

**Muting Mode**

Two examples are shown, both conveyor applications with a safety light curtain protecting the dangerous area. In-line and cross beam muting is used to allow the material to pass through the light curtain without stopping the machine. Any other object or person will be detected by the light curtain which will initiate machine stop.

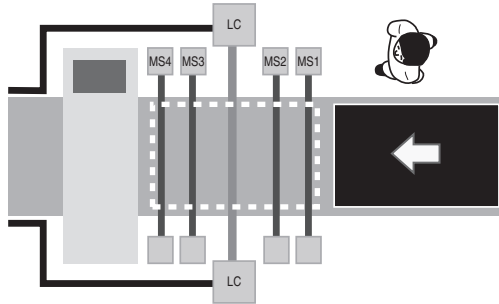

In-line muting requires the material to break the beams in a sequence, as shown. Only if all four MS beams are broken in turn and then clear in turn will the light curtain allow material through without initiating machine stop.

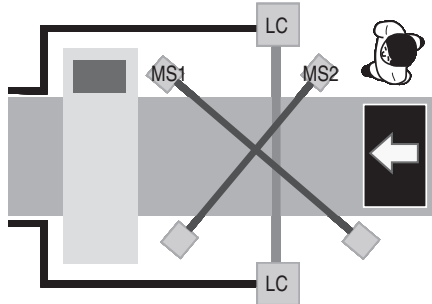

Cross-beam muting requires the material to break the beams in a sequence. MS1 first and then MS2. Only if the beams are broken in turn and then clear in turn will the light curtain allow material through without initiating machine stop.

**Auto Initiation Sequence (Stepping)—Double Break Shown**

Auto initiation allows the machine to start and stop according to the number of times the light curtain beams are broken and cleared. Illustrated below is the MSR22LM set to auto initiation double break mode (after initial start-up sequence). Single- or three-break modes can also be selected.

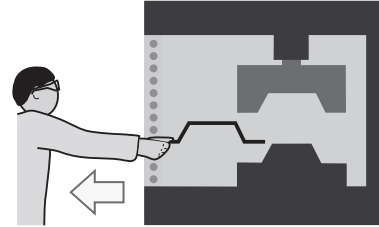

First break—processed material removed

First clear—light curtain clear

Machine remains in stop mode

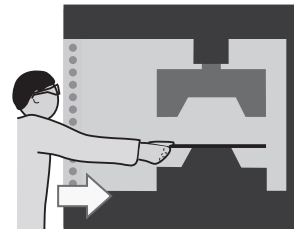

Second break—new material inserted

Machine remains in stop mode

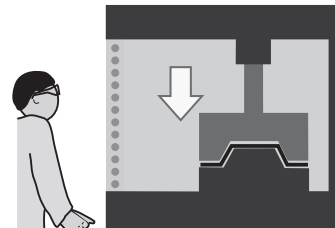

Second clear—light curtain clear

Machine starts. Upon completion of cycle first break will start sequence again.

# Specialty Safety Relays

## MSR42 Control Module



### Description

The MSR42 multi-function safety relay is the control module for the GuardShield Micro 400 safety light curtain, but can also be used with any light curtain. This versatile Category 4 safety device has a pair of PNP solid state, 400 mA OSSDs for direct connection to the final switching device. When safety relay outputs are required, the MSR42 easily accommodates the interconnection of up to three MSR45E safety relay expansion modules, each providing a pair of safety relay outputs. Simply connect ribbon cable connectors from the back of the MSR42 to each of the MSR45E modules for a series of interconnections for two PNP OSSDs, and six N.O. relay outputs.

The MSR42 has four software configurable inputs. These configurable safety inputs allow the connection of a multitude of safety devices such as safety light curtains, safety laser scanners, e-stops, safety switches, etc.

This 22.5 mm DIN mount multi-function safety module has both hard wired and software configurable operating modes. The removable spring terminal connectors on the MSR42 allow for ease of wiring of the device as well as hard-wired operating mode configuration.

Manual/automatic reset and start/restart can be configured by simply changing the wiring (see basic configuration examples).

Features such as two or four sensor muting, connecting up to two additional safety light curtains or other safety devices and configuring one or two auxiliary outputs are easily configured using the optical interface with the supplied software.

The MSR42 and Micro 400 light curtains support fixed blanking which is only available in the basic configuration mode and configured through a "teach-in" selector switch via the GPIO pins.

### Features

- Category 4 per EN 954-1
- SIL CL3 IEC 61508, IEC 62061
- 22.5 mm housing
- Stop category 0, 1
- 24V DC supply voltage
- Manual, monitored or automatic reset
- Thirteen diagnostic LEDs
- Unique design allows for easy addition of relay expansion modules
- Removable terminal blocks
- One or two configurable auxiliary, standard outputs
- Connection of one or two additional safety devices
- RJ45 connections for Micro 400 safety light curtain
- Two or four sensor muting (Micro 400 only)
- Fixed blanking (Micro 400 only)
- Two sensor muting all GuardShield light curtains
- Supports up to three MSR45E expander units
- Free configuration software can be downloaded at [www.ab.com/safety](http://www.ab.com/safety)

### Specifications

Safety Ratings	
Standards	EN 954-1, IEC/EN 60204-1, IEC 61496-1
Safety Classification	Cat. 4 per EN 954-1 (ISO 13849-1), SIL CL3 per EN IEC 61508, PLe per ISO 13849-1
Functional Safety Data * <b>Note:</b> For up-to-date information, visit <a href="http://www.ab.com/Safety/">http://www.ab.com/Safety/</a>	PFH <sub>D</sub> : < 9.00E-10 MTTF <sub>D</sub> : > 331 years For use in SIL3 systems (according to IEC 61508) depending on the architecture and application characteristics
Certifications	CE Marked for all applicable directives, cULus, and TÜV
Power Supply	
Input Power Entry	24V DC
Power Consumption	2.4 W (semi-conductor outputs unloaded)
Inputs	
Safety Inputs	2 N.C. or 2 OSSD, Micro 400 software selectable
Input Resistance, Max.	—
Reset	Auto./manual or manual monitored
Power On Delay Time	Determined by configuration
Response Time	Determined by configuration
Outputs	
Safety Contacts	2 PNP, 400 mA each
Auxiliary Contacts	2 PNP, configurable
Environmental and Physical Characteristics	
Enclosure Type Rating/ Terminal Protection	IP20/ IP20
Operating Temperature [C (F)]	0...55 ° (32...131 °)
Vibration	0.35 mm 10...55 Hz
Mounting	35 mm DIN Rail
Weight [g (lbs)]	130 (0.287)
Conductor Size, Max.	1 x 2.5 mm <sup>2</sup> (14 AWG) stranded

\* Usable for IEC 62061. Data is based on the following assumptions:  
- Mission time/Proof test interval of 20 years

### LED Indicators (Basic Configuration) \*❄

LED	Green	Red
Lamp	—	—
GPI04	Automatic start	Manual start (off)
GPI03	Manual or automatic start	Manual start (off)
GPI02	Configurable	Configurable
GPI01	Configurable	Configurable
OSSD2	Output active	Output inactive
OSSD1	Output active	Output inactive
Info2 (LED)	Configurable	Configurable
Info1 (LED)	Configurable	Configurable
IN2	Start release	No start release signal
IN1	No test input	Test input
0V	—	—
+24V	Power connected	No power connected

\* All I/O is configurable except OSSD1 and OSSD2.

❄ LED behavior depends on configuration (see instruction sheet for details).

**Product Selection**

Inputs	Safety Outputs	Auxiliary Outputs	Terminals	Reset Type	Power Supply	Cat. No.
GuardShield Micro 400 and 4 x GPIO	2 PNP	2 PNP, configurable	Removable	Auto./manual or manual monitored	24V DC	<b>440R-P226AGS-NNR</b>

**Accessories**

Description	Cat. No.
MSR45E—Safety Relay for MSR41 or MSR42 (requires ribbon cable connection)	440R-P4NANS
Ribbon cable—for one MSR45E	<b>440R-ACABL1</b>
Ribbon cable—for two MSR45Es	440R-ACABL2
Ribbon cable—for three MSR45Es	440R-ACABL3
Replacement terminal block kit—MSR42	440R-ATERM2P
Replacement terminal block kit—MSR45E	440R-ATERM2C
USB optical interface software configuration tool used to configure the MSR42	445L-AF6150
Replacement suction cup	445L-AF6151
Optical interface fastener	445L-AF6152

**Approximate Dimensions**

Dimensions are shown in mm (in.). Dimensions are not intended to be used for installation purposes.

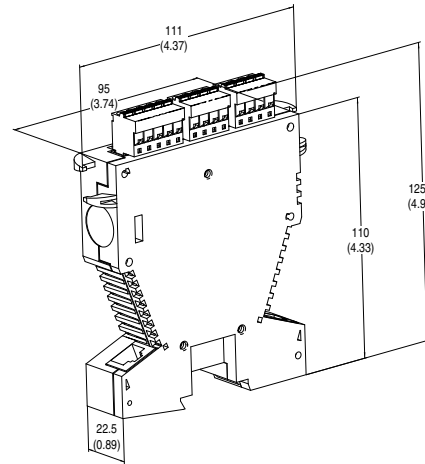

**Typical Wiring Diagrams**

**Basic Configurations (No Software)**

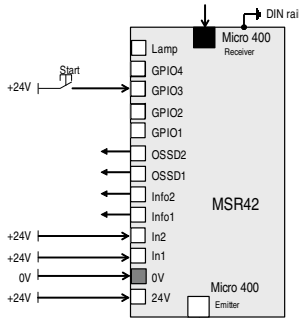

**Micro 400 Light Curtain, Manual Reset, No Output Monitoring**

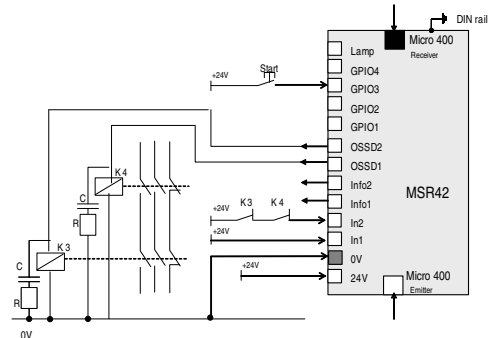

**Micro 400 Light Curtain, Manual Reset, Start/Restart Monitored Output**

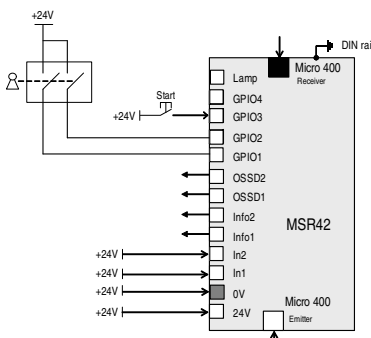

**Fixed Blanking, Micro 400 Light Curtain, Manual Reset, No Output Monitoring**

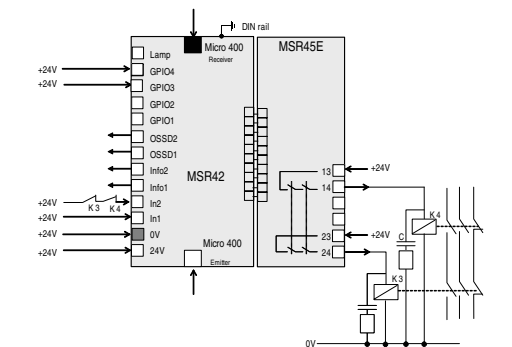

**Micro 400 Light Curtain, Automatic Reset, Start/Restart Monitored Output and MSR45E Expansion Module**

**5-Safety Relays**

Logic  
**Specialty Safety Relays**  
 MSR42 Control Module

Software Configurations

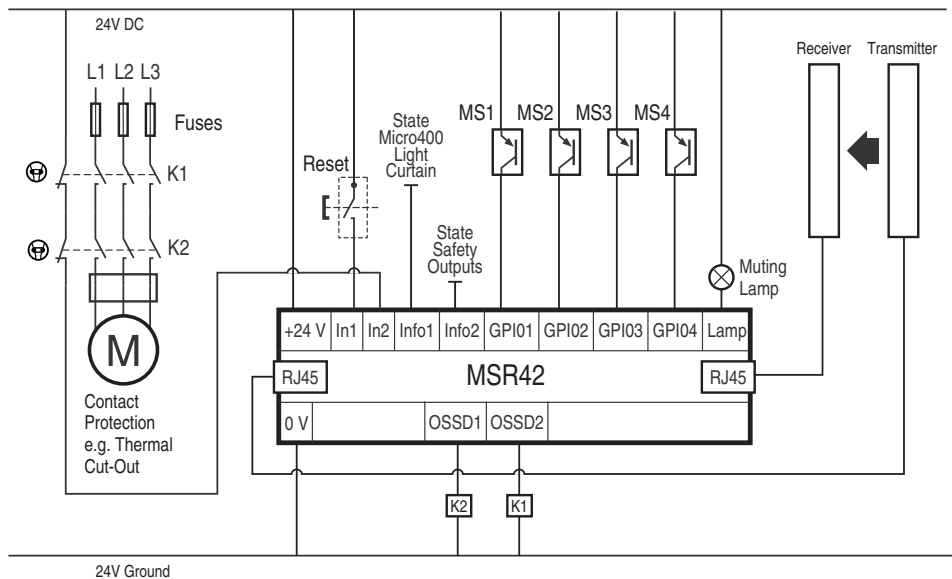

**Note:** Four Sensor T-type muting: GuardShield Micro 400, four muting PNP sensors, manual reset, output monitoring

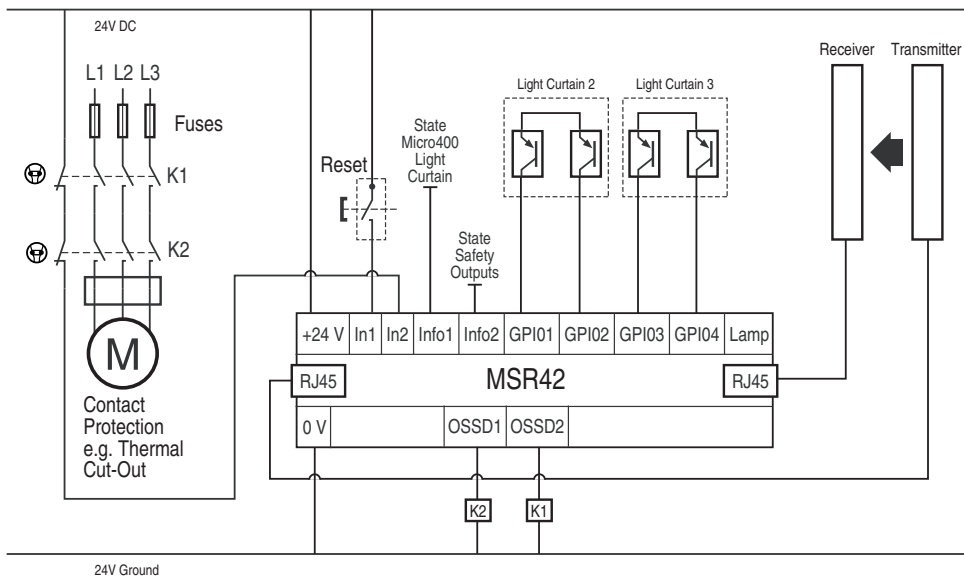

**Note:** Three-light curtain application: GuardShield Micro 400 light curtain, two GuardShield light curtains, manual reset, output monitoring

**Application Details**

**MSR42—Shown connected to safety light curtains.**

Multiple settings are available offering a variety of advantages.

**Protective Mode**

Example shows a press protected by a safety light curtain connected to the MSR42.

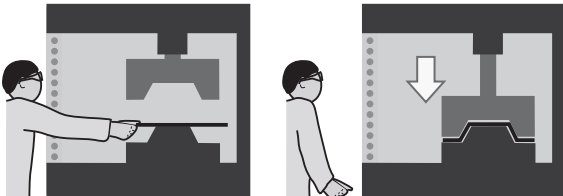

In machine operation, whenever the light curtain beams are broken the press immediately stops to help avoid danger to the operator. Once the beams are cleared the machine can then be started.

**Muting Modes**

Four conveyor examples: All conveyor applications shown with a safety light curtain helping protect the dangerous area. In-line and cross beam muting is used to allow the material to pass through the light curtain without stopping the machine. Any other object or person will be detected by the light curtain which will initiate machine stop.

**Four Sensor T-type**

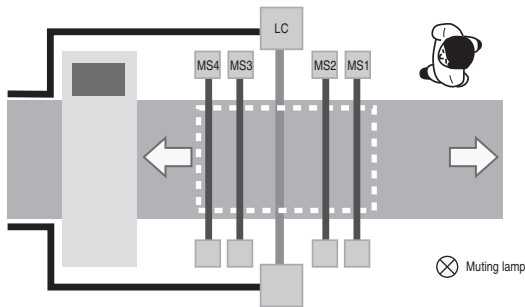

**Bi-directional muting:** In-line muting requires the material to break the beams in a sequence, as shown. Only if all four muting sensor (MS) beams are broken in turn and then clear in turn will the light curtain allow material through without initiating machine stop.

**Two Sensor L-type**

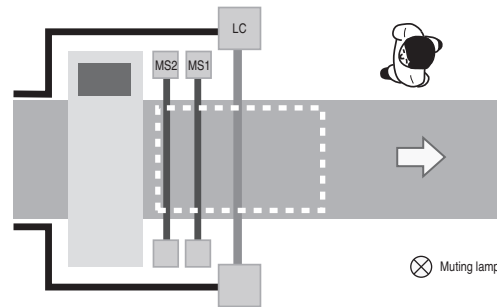

**Uni-directional muting:** This will allow material to exit the machine but not allow material or personnel to enter the machine without a fault condition. Only if both MS beams are broken in-turn and then cleared in-turn, will the light curtain allow material through without initiating a machine stop.

**Two Sensor T-type**

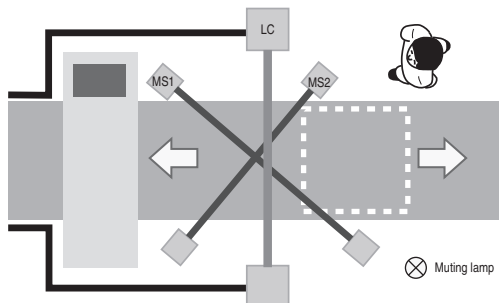

**Bi-directional muting:** Cross-beam muting requires the material to break the beams in a sequence. MS1 first and then MS2. Only if the beams are broken in turn and then cleared in turn will the light curtain allow material through without initiating machine stop.

**Two Sensor T-type with Enable**

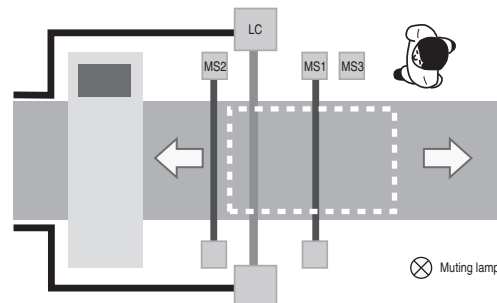

**Bi-directional muting:** The MS3 is an input to the MSR42 from a PLC output card. The MS3 enables the muting function to be performed. If a high signal is not detected on MS3, the muting function will not operate even if the MS1 and MS2 beams are broken. Only if MS3 is high and both MS beams are broken in-turn and then cleared in-turn, will the light curtain allow material through without initiating a machine stop.

## Specialty Safety Relays

### CU2 Stop Motion Monitors



#### Description

The CU2 control unit is a compact timing and stop motion detector interface module. By utilizing two independent inductive proximity inputs, which monitor the movement of two metal parts of the machine (e.g., sprockets, cams or linkages). The control unit detects when hazardous motion has ceased. When the hazardous motion has stopped the unit will send a signal to unlock guard locking devices. It has been developed to integrate guard locking interlock switches on machines which have variable or unpredictable run down cycles.

A removable cover allows access to the DIP switches and potentiometer which control the timing. The on-delay may be adjusted between 0.1 seconds to 40 minutes, through a series of 4 broad time ranges. The final adjustment is made by a potentiometer.

The Y1/Y2 terminals provide a check of contactors at machine power up. This is only relevant to certain special applications. For normal use these terminals should be linked. After all motion has ceased, the normally open safety on contacts close, which may be used to energize electrically operated solenoid locking guard switches. In addition the normally closed contacts open to indicate the unit's status.

LED indication in the unit displays power, timer on, and outputs.

#### Features

- Category 1 per EN 954-1
- Stop category 1
- NPN and PNP inputs
- Timed off-delay 0.1 s...40 min
- Two N.O. safety outputs
- One N.C. auxiliary output

#### LED Indicators

Red	Power on
Red/Green	Timing/Output On

#### Specifications

Safety Ratings		
Standards	EN 954-1, ISO 13849-1, IEC/EN 60204-1, IEC 60947-5-1, ANSI B11.19, AS4024.1	
Safety Classification	Cat. 1 per EN 954-1 (ISO 13849-1), SIL CL1 per EN IEC 62061, PL c per ISO 13849-1	
Certifications	CE Marked for all applicable directives, cULus, c-Tick, and TÜV	
Power Supply		
Input Power Entry	24V AC/DC or 110/230V AC	
Power Consumption	<4 VA	
Inputs		
Safety Inputs	1 NPN and 1 PNP, Normally Open	
Input Resistance, Max.	500 Ω	
Reset	Automatic/Manual	
Outputs		
Safety Contacts	2 N.O.	
Auxiliary Contacts	1 N.C.	
Rated Impulse withstand Voltage	2500V	
Switching Current @ Voltage, Min.	10 mA @ 10V	
Fuses, Output	5 A quick acting (external)	
Electrical Life (Operations)	220V AC/4 A/880VA cosφ = 0.35...0.1 M 220V AC/1.7 A/375VA cosφ = 0.6...0.5 M 30V DC/2 A/60 W = 1 M 10V DC/0.01 A/0.1 W = 2 M	
Mechanical Life	2,000,000 operations	
Utilization Category		
Inductive: B300: AC-15	5 A @ 250V AC	5 A @ 120V AC
Inductive: DC-13	3 A/24V DC	
Environmental and Physical Characteristics		
Enclosure Type Rating/ Terminal Protection	IP40 (NEMA 1), DIN 0470/ IP20, DIN 0470	
Operating Temperature [C (F)]	-10...+55 ° (14...131 °)	
Vibration	0.75 mm (0.30 in) peak, 10...55 Hz	
Shock	30 g, 11 ms half-sine	
Mounting	35 mm DIN Rail	
Weight [g (lbs)]	360 (0.79)	
Conductor Size, Max.	1 x 2.5 mm <sup>2</sup> (14 AWG) stranded, 1 x 4 mm <sup>2</sup> (12 AWG) solid	

- \* Usable for ISO 13849-1:2006 and IEC 62061. Data is based on the following assumptions:
- Mission time/Proof test interval of 20 years
  - Functional test at least once within six-month period

**Product Selection**

Description	Sensor Voltage	Sensor Size (mm)	Sensing Distance (mm)	Terminals	Reset Type	Control Unit Voltage	Cat. No.
Controller and Sensors	24V DC supplied by Control Unit	12	3	Fixed	Automatic/Manual	24V AC/DC	440R-S07279
						110/230V AC	440R-S07280
		18	5			24V AC/DC	440R-S07281
						110/230V AC	440R-S07282
		30	10			24V AC/DC	440R-S07283
						110/230V AC	440R-S07284

When you order a combination Cat. No.	You will receive a control unit, an NPN sensor and a PNP sensor.
440R-S07279	440R-S07139, 872C-D3NN12-E2, and 872C-D3NP12-E2
440R-S07280	440R-S07140, 872C-D3NN12-E2, and 872C-D3NP12-E2
440R-S07281	440R-S07139, 872C-D5NN18-E2, and 872C-D5NP18-E2
440R-S07282	440R-S07140, 872C-D5NN18-E2, and 872C-D5NP18-E2
440R-S07283	440R-S07139, 872C-D10NN30-E2, and 872C-D10NP30-E2
440R-S07284	440R-S07140, 872C-D10NN30-E2, and 872C-D10NP30-E2

**Accessories**

Description	Power Supply	Size (mm)	Output Type	Cat. No.
Control Unit Only	24V AC/DC	45	2 N.O. & 1 N.C.	440R-S07139
	110/230V AC		2 N.O. & 1 N.C.	440R-S07140
Sensor Only	24V DC supplied by Control Unit	12	NPN	872C-D3NN12-E2
			PNP	872C-D3NP12-E2
		18	NPN	872C-D5NN18-E2
			PNP	872C-D5NP18-E2
		30	NPN	872C-D10NN30-E2
			PNP	872C-D10NP30-E2
500 mA fuse—Bussmann Cat. No. ETF-500 mA				440R-A31562

**Approximate Dimensions**

Dimensions are shown in mm (in.). Dimensions are not intended to be used for installation purposes.

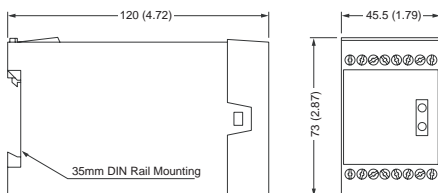

**Block Diagram**

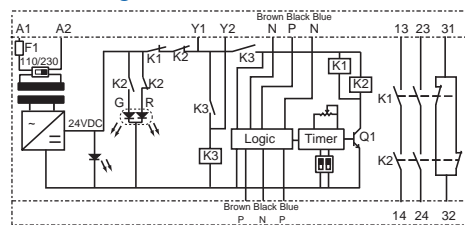

**Typical Wiring Diagrams**

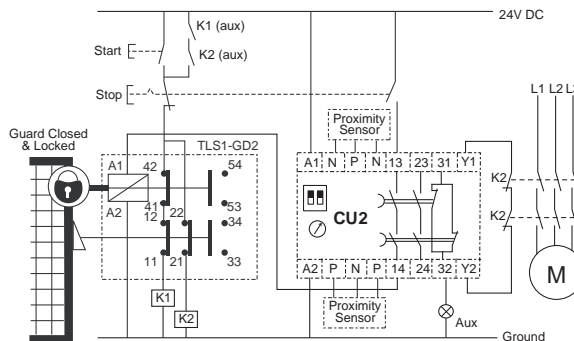

**Guard Locking Safety Gates, Motion Sensors, Delayed Gate Release, Automatic Reset, Monitored Output**

**5-Safety Relays**

## Specialty Safety Relays

### CU2 Sensor Details, Stop Motion Monitors



#### Description

Bulletin 872C WorldProx inductive proximity sensors are self-contained, general purpose, solid-state devices designed to sense the presence of ferrous and nonferrous metal objects without touching them.

The switch body consists of a plastic face and a nickel-plated brass barrel. It meets NEMA 1, 2, 3, 4, 6P, 12, 13 and IP67 (IEC 529) enclosure standards. The electronic circuitry is fully potted for protection against shock, vibration, and contamination.

The CU2 is designed to operate with one normally-open NPN and one normally-open PNP inductive proximity sensor.

The sensors translucent end caps glow when the LED indicator is on, and are visible from almost every angle.

The sensors contained in this section are some of the more popular size inductive proximity sensors. See the Rockwell Automation/Allen-Bradley Sensors catalog for an extensive range of proximity sensors.

#### LED Indicators

Amber	Output energized, 360° visibility
-------	-----------------------------------

#### Specifications

Standards	EN 954-1, ISO 13849-1, IEC/EN 60204-1, IEC 60947-5-1, ANSI B11.19, AS4024.1
Safety Classification	Cat. 1 per EN 954-1 (ISO 13849-1)
Certifications	CE Marked for all applicable directives, cULus, c-Tick, and TÜV
Operating Voltage	10...30V DC
Sensing Distance	2, 5 or 10 mm
Correction Factors	Mild Steel = 1.0 Stainless Steel = 0.7...0.8 Brass = 0.4...0.5 Aluminum = 0.3...0.4 Copper = 0...0.3
Load Current, Max.	200 mA
Outputs	NPN or PNP normally open
Leakage Current	≤10 mA
Sensor Voltage Drop	≤1.64V
Repeatability	≤2%
Hysteresis	≤10% typical
Status Indicators	Red = Output energized
Operating Temperature [C (F)]	-25...+70 ° (-13...+158 °)
Relative Humidity	95%
Enclosure Type Rating	NEMA 1, 2, 3, 4, 6P, 12, 13, IP67
Protection	False pulse on power, transient noise, reverse polarity, short circuit, overload
Cable Size	3 x 1 mm <sup>2</sup> (26 AWG) stranded
Cable Length	2 m (6.5 ft)
Material	Plastic-faced, nickel-plated brass barrel
Mounting	M12, M18 or M30 Flush Fitting (Shielded Sensing)/IP20, DIN 0470
Shock	30 g, 11 ms half-sine
Vibration	1 mm peak, 10...55 Hz

**Note:** See Output Ratings on page 1-39 for details. Consult factory for ratings not shown.

#### Approximate Dimensions

Dimensions are shown in mm (in.). Dimensions are not intended to be used for installation purposes.

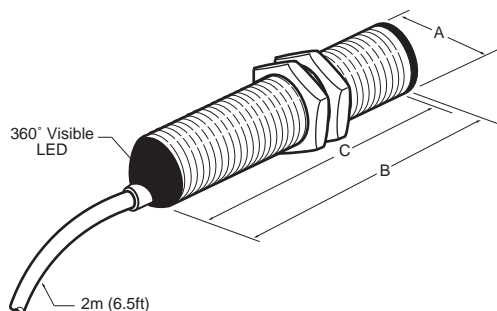

Thread Size	Shielded	mm (inches)		
		A	B (max)	C (min)
M12 x 1	Yes	12 (0.47)	50.8 (2.00)	46.7 (1.84)
M18 x 1		18 (0.71)		
M30 x 1		30 (1.18)		

# Specialty Safety Relays

## CU2 Sensor Details, Stop Motion Monitors

### Application Details

#### Application Accessories



**PNP and NPN Inductive Sensors for use with CU2**  
Sensors detect when motion has ceased by monitoring two targets on moving metal parts. When motion has ceased the CU2 begins timing down. Once preset time limit has been passed the CU2 sends a single allowing locked guard to be opened.

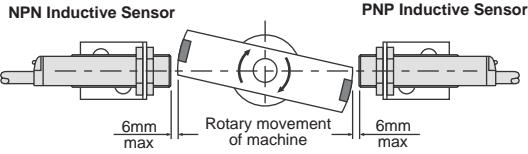

**CU1 remote indication unit:**  
A remote indication unit to indicate the status of the circuit can be connected to the CU 1s, R1, R2 and R3 connections.

#### Adjustable Time Delay

DIP switches general time setting and the potentiometer fine tunes the time settings. Easy access 500 mA<sup>T</sup> replaceable fuse.



#### General time settings via DIP switches

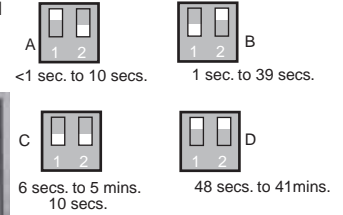

#### Fine adjustment time setting via potentiometer



### Typical Wiring Diagrams

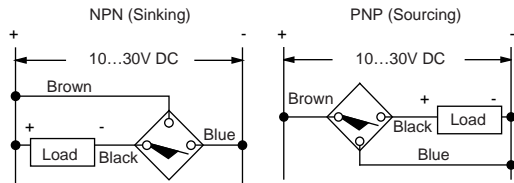

## Specialty Safety Relays

### MSR57P Safe Speed and Standstill Monitor



#### Description

The MSR57P speed monitoring safety relay is designed to solve motion applications which require interaction by personnel during operation. It connects to any drive and monitors the speed using currently installed encoders. The MSR57P can be configured to unlock the access door only when the machine is either stopped or at a safe speed defined by the user. If required, the speed monitoring relay can monitor an enabling switch to constantly monitor personnel while in the hazardous area. Other supported functions are safe maximum speed and zero speed detection.

The MSR57P can be configured and monitored via two methods: drive explorer using a PC and the standard HIM device. During configuration, the user can set a variety of parameters to the specific requirements of their application including type of input devices, quantity, door locking and monitoring, enabling switches and a maintenance (safe speed) mode.

The MSR57P can easily be adapted to current installations with standard drives or drives with the safe-off feature. The safety relay uses standard outputs to control the drives speed but uses safety outputs to control the outputs of the drive. The speed is determined by using an encoder(s). This device can monitor the encoder data which is already transmitting to the drive, assuming an encoder is already installed, or a new encoder can be installed and only connected to the MSR57P. Two encoders are needed for Category 4, SIL 3 applications which cannot exclude shaft slippage and breakage.

This device also supports multiple axis applications. During configuration, it can be setup to be the first, middle or last axis in the chain. This is important since the input devices will all be installed on the first unit only while the output devices are connected to the last MSR57P in the chain.

#### Features

- SIL 3 IEC 61508
- Category 4 per EN 954-1
- Stop category 0, 1, 2
- Six N.O. solid-state safety outputs
- Four solid-state auxiliary outputs
- One or two encoders (sin/cos and TTL)
- Eight diagnostic LEDs
- DPI configuration port
- 67.5 mm DIN Rail housing
- Removable terminals

#### Specifications

Safety Ratings	
Standards	EN 954-1, ISO 13849-1, ISOTR 12100, IEC/EN 60204-1, ANSI B11.19, AS4024.1
Safety Classification	Cat. 4 per EN 954-1 (ISO 13849-1), SIL CL3 per EN IEC 62061, PLe per ISO 13849-1
Functional Safety Data *	PFH <sub>D</sub> : See website MTTF <sub>D</sub> : See website <b>Note:</b> For up-to-date information, visit <a href="http://www.ab.com/Safety/">http://www.ab.com/Safety/</a>
Certifications	cULus, c-Tick, and TÜV
Power Supply	
Input Power Entry	24V DC, 0.8...1.1 x rated voltage PELV/SELV
Power Consumption	5 W
Inputs	
Safety Inputs	1 N.C. & 1 N.O., 2 N.C., 1 N.C., 2 OSSD
Input Simultaneity	Infinite or 3 sec (configurable)
Input Resistance, Max.	4 K Ω
Reset	Auto./Manual or Manual Monitored
Response Time	Configurable
Outputs	
Safety Contacts	6 N.O. Solid State
Auxiliary Contacts	4 N.O. Solid State
Current, Max	Outputs 14, 24, 68, 78 24V DC, 2 A, short-circuit protected Outputs 34, 44 24V DC, 100 mA, short-circuit protected Outputs Y35, Y37 24V DC, 50 mA, short-circuit protected Door switches 51, 52 24V DC, 750 mA, short-circuit protected Outputs Y1, Y32, Y33 24V DC, 100 mA, short-circuit protected Pulse Outputs S11, S21 24V DC, 100 mA, short-circuit protected Pulse Inputs S12, S22, S32, S42, S52, S62, S72, S82, X32, X42, S34, Y2 8.5 mA per input
Environmental and Physical Characteristics	
Enclosure Type Rating/ Terminal Protection	IP40 (NEMA 1)/ IP20, DIN 0470
Operating Temperature [C (F)]	-5...+55 ° (23...131 °)
Vibration	10...55 Hz, 0.35 mm
Shock	10 g, 16 ms, 100 shocks
Mounting	35 mm DIN Rail
Weight [g (lbs)]	335 (0.74)
Conductor Size, Max.	0.2...2.5 mm <sup>2</sup> (24...12 AWG)

- \* Usable for ISO 13849-1:2006 and IEC 62061. Data is based on the following assumptions:
- Mission time/Proof test interval of 20 years
  - Functional test at least once within six-month period

**Product Selection**

Inputs	Safety Outputs	Auxiliary Outputs	Terminals	Reset Type	Power Supply	Cat. No.
5 x 1 N.C., 2 N.C., LC, 1 N.O. + 1 N.C.	6 N.O. Solid State	4 N.O. Solid State	Removable	Auto./Manual or Manual Monitored	24V DC	440R-S845AER-NNL

**Accessories**

Description	Cat. No.
MSR57 Encoder cable with flying leads (2.5 meters)	1585J-M8RB-2M5
3 meter cable HIM	1202-C30
1 meter cable HIM	1202-C10
AnaCANda serial converter (RS232)	1203-SSS
AnaCANda USB converter	1203-USB
HIM full numeric LCD IP20 (NEMA 1)	20-HIM-A3
Kinetix 6000/7000 low profile connector kit	2090-K6CK-Dxxx
Kinetix 2000 low profile connector kit	2090-K2CK-D15M
HIM to MSR 57 cable (1 meter)	20-HIM-H10
Sin/Cos encoder (1024 PPR)	842HR-xJxxx15FWY2
TTL encoder (size 20)	845T-xxxxxxx
TTL encoder (size 25)	845H-SJxxx4xxYxx

**Approximate Dimensions**

Dimensions are shown in mm (in.). Dimensions are not intended to be used for installation purposes.

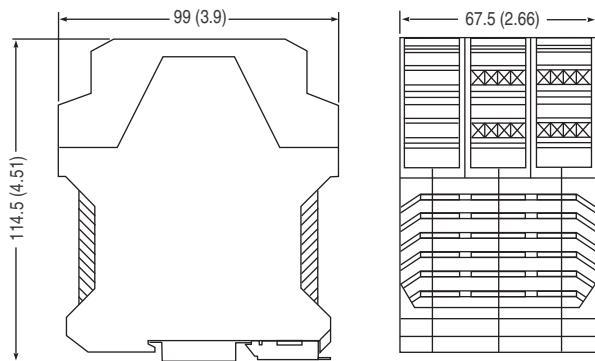

**Block Diagram**

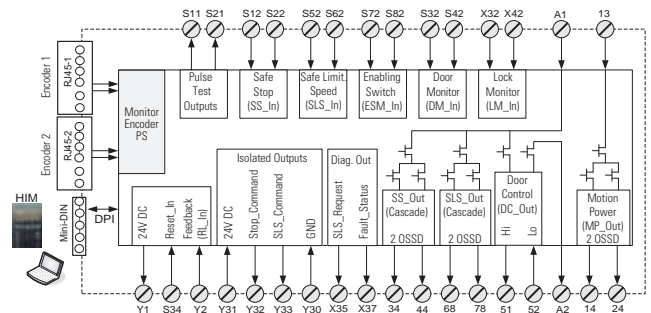

Logic  
**Specialty Safety Relays**  
 MSR57P Safe Speed and Standstill Monitor

Typical Wiring Diagrams

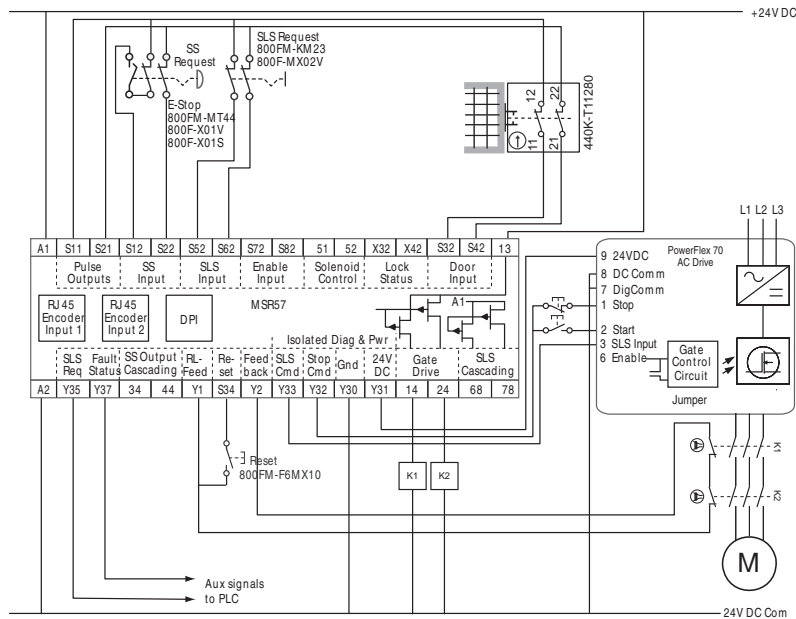

**Note:** Cat. 1 stop, 1 encoder, door monitoring, safe limited speed, PowerFlex 70 without safe off.

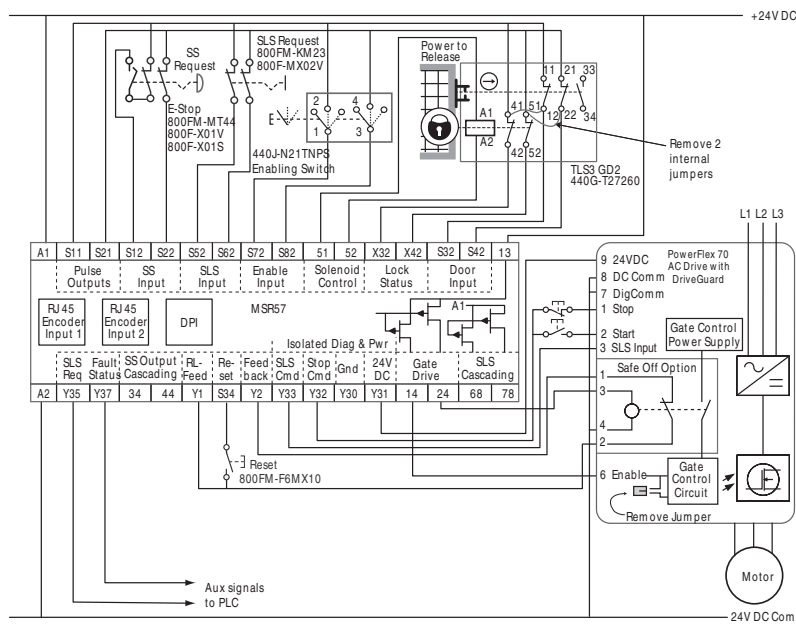

**Note:** Cat. 1 stop, 1 encoder, door monitoring, enabling switch, safe limited speed, PowerFlex 70 with safe off.

## Application Details

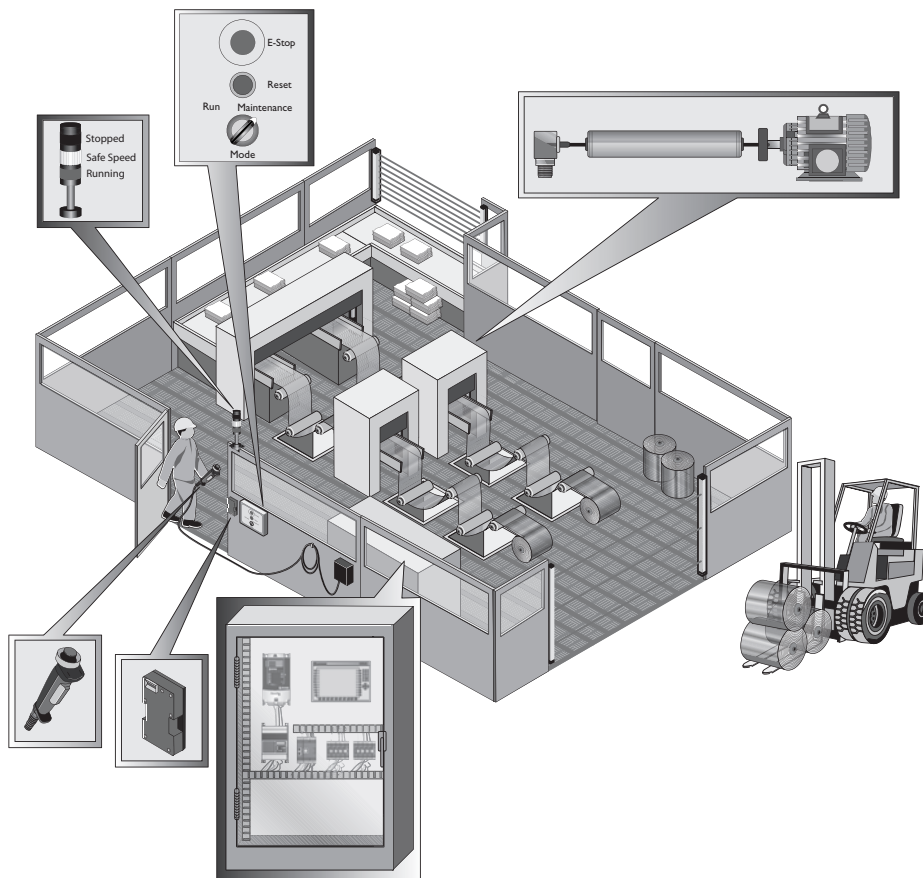

### Operating Conditions

- The door is closed and locked with a TLS3 safety switch
- The machine is running at normal speed

### Maintenance Conditions

- In order to remove a jam condition or during start-up personnel must enter the hazardous area.
- The operator moves Limited Speed Selector switch to "enable."
- The MSR57 monitors speed profile and verifies drive is reducing speed per the preconfigured profile.
- Once the speed is equal to or below limited speed value, the door is unlocked.
- If configured, user must hold enabling switch in the middle position before opening door. Otherwise the machine will shutdown.
- The operator performs maintenance on the machine.
- Once maintenance is complete, the operator exits machine, closes door and moves the safe limited speed switch to "maintenance" mode BEFORE releasing the enabling switch.
- The machine will resume normal speed according to the drive profile.

### Remarks

- The MSR57 can also monitor if the speed has exceeded a preconfigured value and shutdown the process.
- The MSR57 is compatible with all drives and uses standard inputs on the drive to perform controlled start and stop sequences.
- Pressing the E-stop at any time, will cause the machine to stop according to the preconfigured stop mode.
- The MSR57 can also be used in cascading applications with multiple MSR57s and drives.

# Specialty Safety Relays

## CU3 Back EMF Monitors



### Description

The CU3 is a control unit which detects stopped motion and is ideal for use with guard locking interlock switches. It is designed to interface with single or three-phase induction motors by measuring the drive voltage and the back electro-magnetic field (emf) of the motor.

The front window of the CU3 can be popped off to reveal a replaceable fuse and a potentiometer. The potentiometer sets the threshold voltage measured at terminals Z1/Z2. The maximum threshold voltage is approximately 2.5V peak (potentiometer turned fully CCW). When the voltage at Z1/Z2 exceeds the threshold voltage, the safety outputs de-energize, and the safety contacts at terminals 13/14 and 23/24 open.

When the supply to a motor is disconnected, motor speed will reduce to zero. During the run down period the back emf generated by the motor is monitored by the CU3. When the level of the back emf dips below the threshold voltage, the safety outputs close. This enables the output device (e.g., solenoid locking or unlocking switch) to be activated.

If the Z1/Z2 circuit opens, the CU3 goes into a fault state, indicated by the fault led. The fault must be corrected and the power to the CU3 cycled to clear the fault state.

The 24V DC version must be operated with an isolated supply. The CU3 is not intended for use with variable frequency drives.

### Features

- Category 1 per EN 954-1
- Stop category 1
- Two N.O. safety outputs
- One N.C. auxiliary output
- Automatic/manual, monitored reset supported
- Motor voltage up to 500V max.

### LED Indicators

Red	Power on
Red/Green	Timing/Output On
Yellow	Fault
Red	Motor Running

### Specifications

Safety Ratings		
Standards	EN 954-1, ISO 13849-1, IEC/EN 60204-1, IEC 60947-5-1, ANSI B11.19, AS4024.1	
Safety Classification	Cat. 1 per EN 954-1 (ISO 13849-1), SIL CL1 per EN IEC 62061, PL c per ISO 13849-1	
Functional Safety Data *	PFH <sub>D</sub> : See website MTTFD: See website Note: For up-to-date information, visit <a href="http://www.ab.com/Safety/">http://www.ab.com/Safety/</a> Suitable for performance levels Plc (according to ISO 13849-1:2006) and for use in SIL3 systems (according to IEC 62061) depending on the architecture and application characteristics	
Certifications	CE marked for all applicable directives, cULus, c-Tick, and TÜV	
Power Supply		
Input Power Entry	24V AC/DC, 115/230V AC	
Power Consumption	<4 VA	
Motor Voltage	500V max.	
Inputs		
Safety Inputs	Z1/Z2 Motor Voltage	
Reset	Automatic/Manual	
Outputs		
Safety Contacts	2 N.O.	
Auxiliary Contacts	1 N.C.	
Rated Impulse withstand Voltage	2500V	
Switching Current @ Voltage, Min.	10 mA/10V	
Fuses, Output	5 A quick acting (external)	
Electrical Life (Operations)	220V AC/4 A/880VA cosφ = 0.35...0.1 M 220V AC/1.7 A/375VA cosφ = 0.6...0.5 M 30V DC/2 A/60 W = 1 M 10V DC/0.01 A/0.1 W = 2 M	
Mechanical Life	2,000,000 operations	
Utilization Category		
Inductive: B300: AC-15	5 A @ 250V AC	5 A @ 120V AC
Inductive: DC-13	3 A/24V DC	
Environmental and Physical Characteristics		
Enclosure Type Rating/ Terminal Protection	IP40, DIN 0470/ IP20 DIN 0470	
Operating Temperature [C (F)]	-10...+55 ° (14...131 °)	
Vibration	0.75 mm (0.30 in) peak, 10...55 Hz	
Shock	30 g, 11 ms half-sine	
Mounting	35 mm DIN Rail	
Weight [g (lbs)]	510 (1.12)	
Conductor Size, Max.	1 x 2.5 mm <sup>2</sup> (14 AWG) stranded, 1 x 4 mm <sup>2</sup> (12 AWG) solid	

\* Usable for ISO 13849-1:2006 and IEC 62061. Data is based on the following assumptions:  
 - Mission time/Proof test interval of 20 years  
 - Functional test at least once within six-month period

**Product Selection**

Safety Outputs	Auxiliary Outputs	Power Supply	Terminals	Reset Type	Cat. No.
2 N.O.	1 N.C.	24V AC/DC*	Fixed	Monitored Manual, Automatic/Manual	440R-S35001
2 N.O.	1 N.C.	110V AC			440R-S35002
2 N.O.	1 N.C.	230V AC			440R-S35003

\* The 440R-S35001 requires an isolated supply when operating on 24V DC.

**Accessories**

Description	Cat. No.
500 mA Fuse—Bussmann Cat. No. ETF-500 mA	440R-A31562

**Application Details**

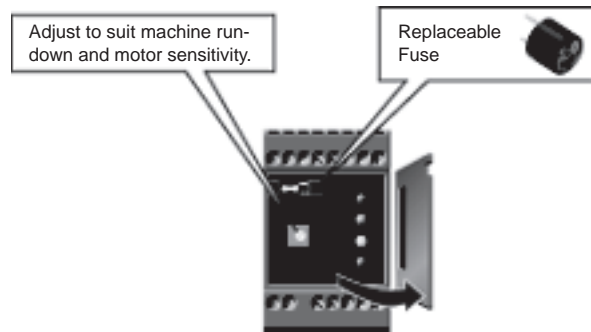

**Approximate Dimensions**

Dimensions are shown in mm (in.). Dimensions are not intended to be used for installation purposes.

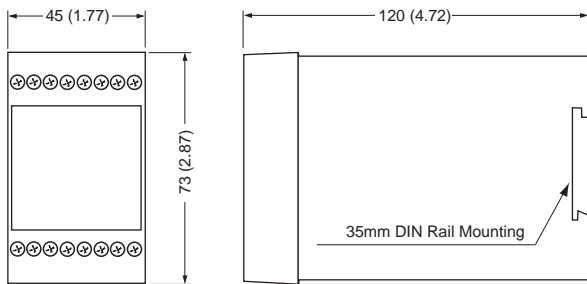

**Block Diagram**

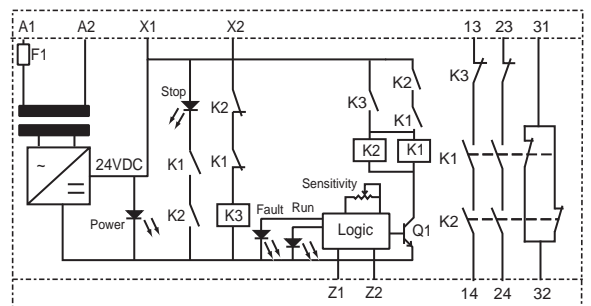

**Typical Wiring Diagrams**

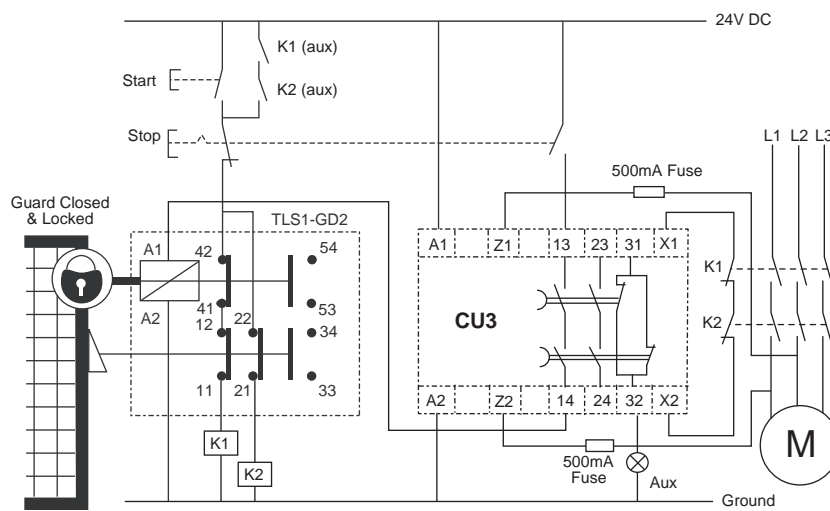

**Guard Locking Safety Gate, Back EMF Detection, Automatic Reset, Monitored Output**

**5-Safety Relays**

# Specialty Safety Relays

## MSR23M Mat Controllers



### Description

The MSR23M control unit is designed to monitor four-wire safety mats that are connected together to form a safeguarded zone. The size of the safeguarded zone is limited by the total input impedance (100 ohms maximum) created by the wiring and connections. The controller is designed to interface with the control circuit of the machine and includes two safety relays to help provide control redundancy.

The controller detects a presence on the mat, a short circuit, or an open circuit. Under each of these conditions, the safety output relays turn off. When interfaced properly, the machine or hazardous motion receives a stop signal, and an auxiliary output turns ON.

### Features

- Category 4
- Stop category 0
- Removable terminals
- Monitored or automatic/manual reset
- Four-wire safety mats sensing

### LED Indicators

Power: Green	Ready, Red = Mat Activated
K1: Green	K1 Closed. If K1 alone is lit, check for short across reset button.
K2: Green	K2 Closed

### Specifications

Safety Ratings		
Standards	EN 954-1, ISO 13849-1, IEC/EN 60204-1, IEC 60947-5-1, ANSI B11.19, AS 4024.5	
Safety Classification	Cat. 3 per EN 954-1 (ISO 13849-1), SIL CL2 per EN IEC 62061, PLe per ISO 13849-1	
Functional Safety Data *	PFH <sub>D</sub> : See website MTTF <sub>D</sub> : See website <b>Note:</b> For up-to-date information, visit <a href="http://www.ab.com/Safety/">http://www.ab.com/Safety/</a> Suitable for performance levels PLe (according to ISO 13849-1:2006) and for use in SIL3 systems (according to IEC 62061) depending on the architecture and application characteristics	
Certifications	CE Marked for all applicable directives, BG, and CSA (24V only)	
Power Supply		
Input Power Entry	24V AC/DC or 115V AC	
Power Consumption	2 W	
Inputs		
Safety Inputs	2 N.C., 4-Wire SM	
Input Resistance, Max.	100 Ω	
Reset	Auto./Manual or Monitored Manual	
Power On Delay Time	40 ms ( Manual Reset); 200 ms (Auto Reset)	
Response Time	15 ms	
Outputs		
Safety Contacts	2 N.O.	
Auxiliary Contacts	1 N.C.	
Thermal Current/ <i>I<sub>th</sub></i>	1 x 8 A or 2 x 7 A nonswitching	
Switching Current @ Voltage, Min.	1 mA/10V	
Fuses, Output	6 A fast acting (external)	
Electrical Life (Operations)	220V AC/4 A/880VA cosφ = 0.35...0.1 M 220V AC/1.7 A375VA cosφ = 0.6...0.5 M 30V DC/2 A/60 W = 1 M 10V DC/0.01 A/0.1 W = 2 M	
Mechanical Life	10,000,000 operations	
Utilization Category (Inductive)		
N.O.—B300 AC-15	3 A @ 250V AC	3 A @ 120V AC
P300 DC-13	3 A @ 24V DC	
N.C.—B300 AC-15	2 A @ 250V AC	2 A @ 120V AC
DC-13	2 A @ 24V DC	
Environmental and Physical Characteristics		
Enclosure Type Rating/ Terminal Protection	IP40 (NEMA 1) DIN 0470/ IP20, DIN 0470	
Operating Temperature [C (F)]	-15...+55 ° (5...131 °)	
Vibration	10 g 10...55 Hz	
Shock	30 g, 11 ms half-sine	
Mounting	22.5 mm housing, 35 mm DIN Rail	
Weight [g (lbs)]	220 (0.485)	
Conductor Size, Max.	1 x 2.5 mm <sup>2</sup> (14 AWG) stranded, 1 x 4 mm <sup>2</sup> (12 AWG) solid	

\* Usable for ISO 13849-1:2006 and IEC 62061. Data is based on the following assumptions:  
 - Mission time/Proof test interval of 20 years  
 - Functional test at least once within six-month period

**Product Selection**

Inputs	Safety Outputs	Auxiliary Outputs	Terminals	Reset Type	Power Supply	Cat. No.
4-Wire Safety Mat	2 N.O.	1 N.C.	Fixed	Automatic/Manual	24V AC/DC	440R-P23073
				Monitored Manual	115V AC	440R-P23074

**Approximate Dimensions**

Dimensions are shown in mm (in.). Dimensions are not intended to be used for installation purposes.

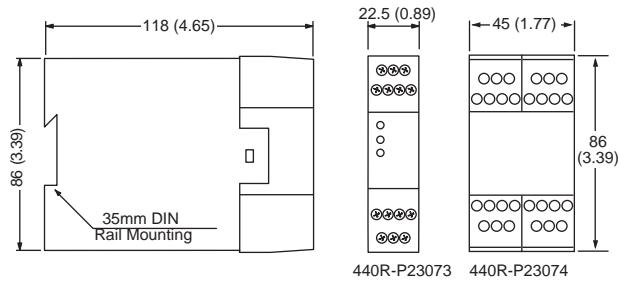

**Block Diagram**

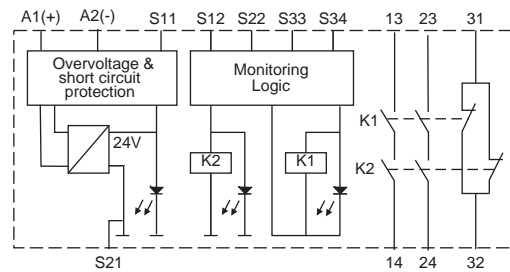

**Typical Wiring Diagrams**

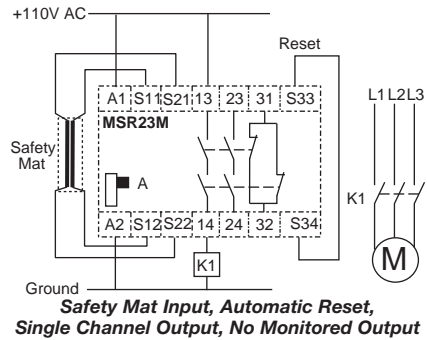
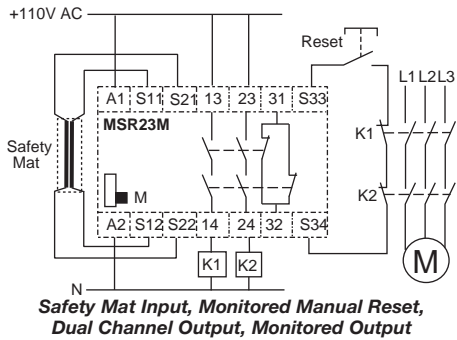

**Application Details**

Disconnect power. Use a screwdriver to pop open cover to reveal internal switches.

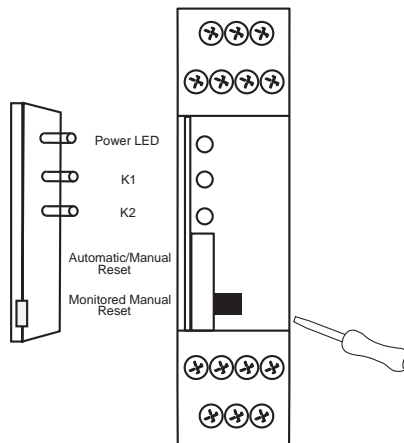

# Logic MatGuard™ Controllers Safety Relays



## Description

The MatGuard Control Unit monitors all of the mats which are connected together to form a safeguarded zone. The safeguarded zone can be up to a total of 100 m<sup>2</sup> and made from any number of mats. The controller is designed to interface with the control circuit of the machine and includes two safety relays to help provide control redundancy.

The controller detects a presence on the mat, a short circuit, or an open circuit. Under each of these conditions, the safety output relays turn off. When interfaced properly, the machine or hazardous motion will receive a stop signal, and an auxiliary output relay turns ON.

The controller comes in two different package styles, a plastic case for surface or wall mounting, and a steel case for surface or wall mounting. Each style offers many of the same basic features. Each controller accepts power supplies of 24V AC/DC, and 110/230V AC. The plastic and steel-cased styles include reset buttons. The steel-cased controller offers extra protection against inadvertent impacts.

Alternatively, see the Product Selection table for safety relays that can also control and monitor safety mats.

## Features

- Selectable voltage supply
- Auto/manual reset
- Four-wire system to detect opens and shorts
- Third party approval—AMTRI, TÜV

## LED Indicators

Green	Power
Green	Auto Reset Mode
Green	Manual Reset Mode
Green	Machine Enabled

## Specifications

Safety Ratings	
Standards	EN1760-1, EN 954-1, ISO13849-1, IEC/EN 60204-1, ANSI RIA R15.06, ANSI B11.19, AS 4024.5
Safety Classification	Cat. 3 per EN 954-1 (ISO 13849-1), SIL CL2 per EN IEC 62061, PLe per ISO 13849-1
Functional Safety Data * <b>Note:</b> For up-to-date information, visit <a href="http://www.ab.com/Safety/">http://www.ab.com/Safety/</a>	PFH <sub>D</sub> : See website MTTF <sub>d</sub> : See website Suitable for performance levels PLe (according to ISO 13849-1:2006) and for use in SIL3 systems (according to IEC 62061) depending on the architecture and application characteristics
Certifications	CE Marked for all applicable directives, cULus, and TÜV
Power Supply	
Input Power Entry	24V AC/DC or 115/230V AC
Power Consumption	6 W, 9V A
Inputs	
Safety Inputs	Safety Mats
Reset	Monitored Manual or Automatic/Manual
Response Time	35 ms, Mat pressed to output open
Outputs	
Safety Contacts	2 N.O.
Auxiliary Contacts	1 N.C.
Switching Current @ Voltage, Min.	10 mA @ 10V
Fuses, Output	5 A fast acting (external)
Electrical Life (Operations)	220V AC/4 A/880VA cosφ = 0.35...0.1 M 220V AC/1.7 A/375VA cosφ = 0.6...0.5 M 30V DC/2 A/60 W = 1 M 10V DC/0.01 A/0.1 W = 2 M
Mechanical Life	10,000,000 operations
Environmental and Physical Characteristics	
Enclosure Type Rating/	4000P: IP65 (NEMA 13); 4000S: IP62 (NEMA 12)/ IP20, DIN 0470
Terminal Protection	
Operating Temperature [C (F)]	-10...+45 ° (14...113 °)
Vibration	0.15 mm, 10...55 Hz
Mounting	Surface (Wall) Mount
Weight [g (lbs)]	4000P: 880 (1.94); 4000S: 3200 (7.05)
Conductor Size, Max.	4000P, 4000S: 1 x 1.5 mm <sup>2</sup> (16 AWG), max.

- \* Usable for ISO 13849-1:2006 and IEC 62061. Data is based on the following assumptions:
- Mission time/Proof test interval of 20 years
  - Functional test at least once within six-month period

**Product Selection**

Inputs	Safety Outputs	Auxiliary Outputs	Terminals	Reset Type	Power Supply	Cat. No.
SM	2 N.O.	1 N.C.	NA	Monitored Manual or Automatic/Manual	24V AC/DC or 115/230V AC	440F-C4000P 440F-C4000S

**Approximate Dimensions**

Dimensions are shown in mm (in.). Dimensions are not intended to be used for installation purposes.

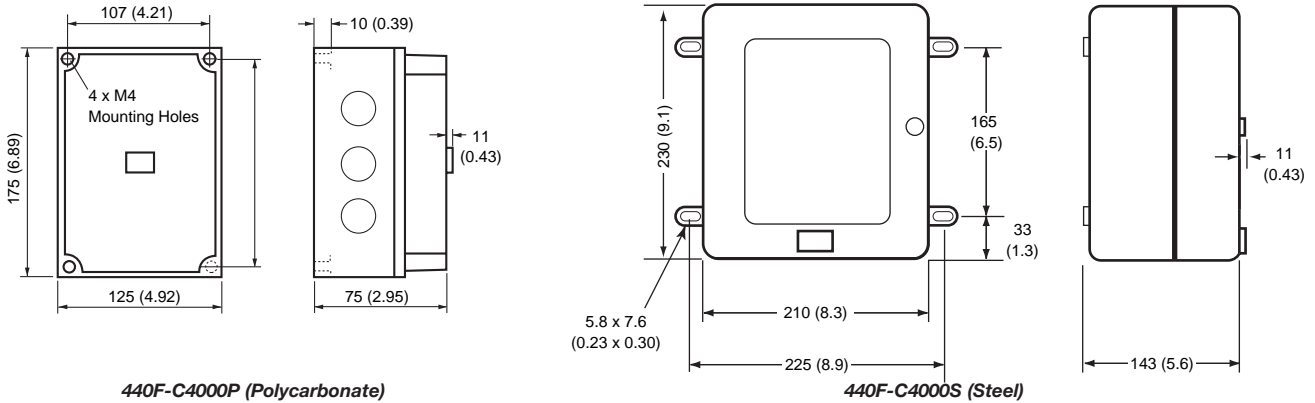

**Block Diagram**

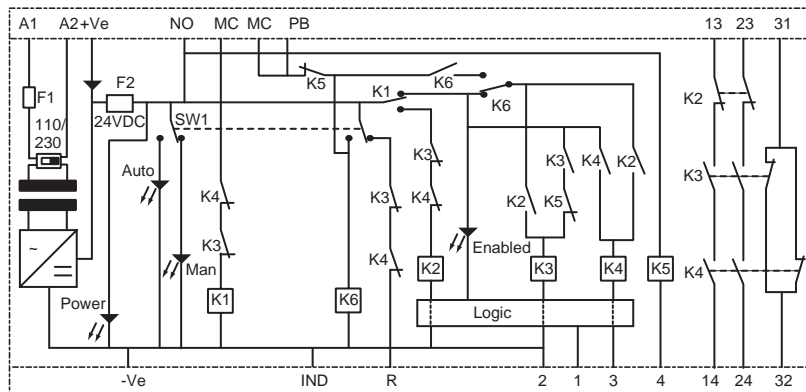

**Typical Wiring Diagrams**

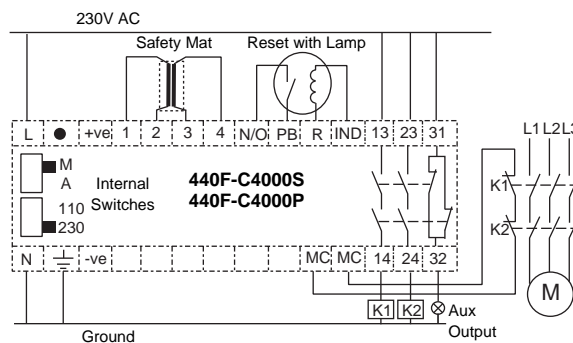

**5-Safety Relays**



### Description

The Safety Mat Manager is designed to monitor multiple safety mats, each with its own connection. The Safety Mat Manager accepts up to eight individual mats with four-pin micro quick disconnect connectors.

The Safety Mat Manager provides an LED status indication for each of the mat connections. Since the LEDs indicate whether the mat is shorted or open, troubleshooting and replacement of a damaged mat within a mat system, is much quicker when compared to a traditional mat system where multiple mats are wired in series.

An internal switch allows for the setting of the reset to automatic/manual or monitored manual. When set to automatic/manual, the reset circuit can be jumpered, connected auxiliary contacts, or connected to an unmonitored manual reset by adding a momentary normally open switch in the monitoring loop. When set to monitored manual, the monitoring circuit must be closed and then opened to activate the outputs.

Stepping on any one of the mats deactivates the safety outputs. The outputs include two or six normally open safety rated outputs used to shut down the machine and one normally closed or normally open auxiliary output to indicate the status of the Mat Manager. The safety outputs have independent and redundant internal contacts to support the safety function.

### Features

- Accepts up to eight individual mats
- Two or six safety output contacts
- One auxiliary output contact
- Automatic/manual or monitored manual reset

### LED Indicators

Green	Power
Green	Machine Enabled
Green	Auto Reset Mode
Green	Manual Reset Mode
Mat Status:	
Green	Run Condition
Red	Stop Condition, Mat Pressed
Off	Not Used/Mat Disabled

### Specifications

<b>Safety Ratings</b>	
Standards	EN 1760-1, EN 954-1, ISO 13849-1, IEC/EN 60204-1, ANSI RIA R15.06, ANSI B11.19, AS 4024.5, E 1760-1
Safety Classification	Cat. 3 per EN 954-1 (ISO 13849-1), SIL CL3 per EN IEC 62061, PLe per ISO 13849-1
Functional Safety Data * <b>Note:</b> For up-to-date information, visit <a href="http://www.ab.com/Safety/">http://www.ab.com/Safety/</a>	PFH <sub>D</sub> : < 2.59 x 10 <sup>-9</sup> MTTF <sub>d</sub> : > 290 years Suitable for performance levels PLe (according to ISO 13849-1:2006) and for use in SIL3 systems (according to IEC 62061) depending on the architecture and application characteristics
Certifications	CE Marked for all applicable directives, cULus, c-Tick, and TÜV
<b>Power Supply</b>	
Input Power Entry	24V AC/DC, 115/230V AC 50/60 Hz
Power Consumption	12 W or 9 VA
<b>Inputs</b>	
Safety Inputs	8, 4-Pin Micro-QD M12 Inputs (4 wire mats)
Input Resistance, Max.	500 Ω
Mat Size [mm (in.)]	100 m <sup>2</sup> (1076 ft <sup>2</sup> ) max.
Reset	Auto./Manual Monitored Manual
Power On Delay/Recovery Time	3 s/48 ms
Response Time	35 ms
<b>Outputs</b>	
Safety Contacts	2 N.O. or 6 N.O.
Auxiliary Contacts	1 N.C. or 1 N.O.
Output Rating*	B300, AC15, 4 A/250V AC; R300, DC13, 2 A/30V DC
Rated Impulse withstand Voltage	2500V
Switching Current @ Voltage, Min.	10 mA @ 10V
Fuses, Output	External 6 A slow blow or 10 A fast acting
Electrical Life (Operations)	220V AC/4 A/880VA cosφ = 0.35...0.1 M 220V AC/1.7 A/375VA cosφ = 0.6...0.5 M 30V DC/2 A/60 W = 1 M 10V DC/0.01 A/0.1 W = 2 M
Mechanical Life	10,000,000 operations
<b>Environmental and Physical Characteristics</b>	
Enclosure Type Rating/ Terminal Protection	IP65 (NEMA 13) steel with polycarbonate face plate/ —
Operating Temperature [C (F)]	-25...45° (-13...113°)
Vibration	0.15 mm, 10...55 Hz
Shock	10 g, 11 ms, half-sine
Mounting	Surface (Wall) Mount
Weight [g (lbs)]	3200 (7)
Conductor Size, Max.	0.2...2.5 mm <sup>2</sup> (24...14 AWG), max.

\* Usable for ISO 13849-1:2006 and IEC 62061. Data is based on the following assumptions:  
- Mission time/Proof test interval of 20 years  
- Functional test at least once within six-month period

\* Ratings vary due to output connectors. See installation instructions for details.





**Description**

The Safedge controllers are designed to operate with the Safedge profiles. The controller continuously monitors the profile for actuation and generates an output signal when the profile is depressed.

The Safedge controller provides a low voltage to the profile. When the profile is pressed, the controller detects a change in resistance and turns off its output relays. When pressure is released from the profile, the output relays of the controller return to an on state. The controller has redundant voltage free positively-guided output relays, which can be used to interface with a machine control system.

The 251 controller comes capable of operating at 24V AC/DC, or 120/230V AC from separate terminals. An internal switch changes the operating voltage from 120V AC to 230V AC. The 252 controller operates at 24V AC/DC.

An auxiliary output relay is available to provide a signal about the controller's status. Three LEDs indicate whether the controller is in RUN, STOP or OPEN condition. The controller operates in manual or automatic reset mode.

**Features**

- One N.O. or two N.O. safety outputs
- One N.C. auxiliary output
- 24V AC/DC or 120/240V AC
- Output monitoring
- LED indicators for RUN, STOP, and OPEN
- Automatic/manual reset

**LED Indicators**

Green	Run
Yellow	Open Circuit
Red	Stop

**Specifications**

<b>Safety Ratings</b>	
Standards	EN1760-2, EN954-1, ISO 13849-1, AS 4024.5, EN 954-1, ANSI B11.19
Safety Classification	Cat. 3 per EN 954-1
Certifications	CE Marked for all applicable directives, cULus, and TÜV
<b>Power Supply</b>	
Input Power Entry	251: 24V AC/DC or 115/230V AC 50/60 Hz; 252: 24V AC/DC 50/60 Hz
Power Consumption	251: < 6 VA 252: < 4 VA
<b>Inputs</b>	
Safety Inputs	Profile: 6 kΩ, 12V DC open circuit, 4V DC run condition Monitoring: 1 N.O.
Response Time	13 ms, max.
<b>Outputs</b>	
Safety Contacts	251: 2 N.O.; 252: 1 N.O.
Auxiliary Contacts	1 N.C.
Rated Impulse withstand Voltage	2500V
Switching Current @ Voltage, Min.	10 mA @ 10V
Fuses, Output	4 A on AC, 2 A on DC (external)
Electrical Life (Operations)	220V AC/4 A/880VA cosφ = 0.3... 0.1 M 220V AC/1.7 A/375VA cosφ = 0.6...0.5 M 30V DC/2 A/60 W = 1 M 10V DC/0.01 A/0.1 W = 2 M
<b>Environmental and Physical Characteristics</b>	
Enclosure Type Rating/ Terminal Protection	251D, 252D: IP40 (NEMA 1); 251P: IP65 (NEMA 13)/ IP20 DIN 0470
Operating Temperature [C (F)]	-10...55° (-14...131°)
Vibration	0.15 mm, 10...55 Hz
Shock	10 g, 11 ms, half-sine
Mounting	Surface mount 35 mm or DIN Rail
Weight [g (lbs)]	251D: 450 (1.0) 252D: 181 (0.4) 251P: 650 (1.4)
Conductor Size, Max.	251D, 252D: 1 x 4 mm <sup>2</sup> (10 AWG) stranded, 1 x 4 mm <sup>2</sup> (10 AWG) solid 251P: 1 x 1.1 mm <sup>2</sup> (18 AWG) stranded, 1 x 1.5 mm <sup>2</sup> (16 AWG) solid

\* Usable for ISO 13849-1:2006 and IEC 62061. Data is based on the following assumptions:  
- Mission time/Proof test interval of 20 years  
- Functional test at least once within six-month period

Product Selection

Inputs	Safety Outputs	Auxiliary Outputs	Terminals	Reset Type	Power Supply	Cat. No.
Safedge	2 N.O.	1 N.C.	Fixed	Automatic/Manual	24V AC/DC or 115/230V AC	440F-C251D
	1 N.O.				24V AC/DC	440F-C252D
	2 N.O.				24V AC/DC or 115/230V AC	440F-C251P

Accessories

Description	Cat. No.
500 mA Fuse—Bussmann Cat. No. ETF-500 mA	440R-A31562
Fuse, 2 A—Bussmann Cat. No. ETF-2	440A-A09197

Block Diagram

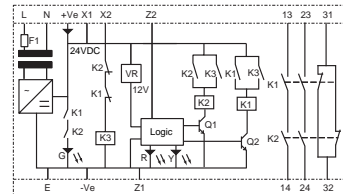

Approximate Dimensions

Dimensions are shown in mm (in.). Dimensions are not intended to be used for installation purposes.

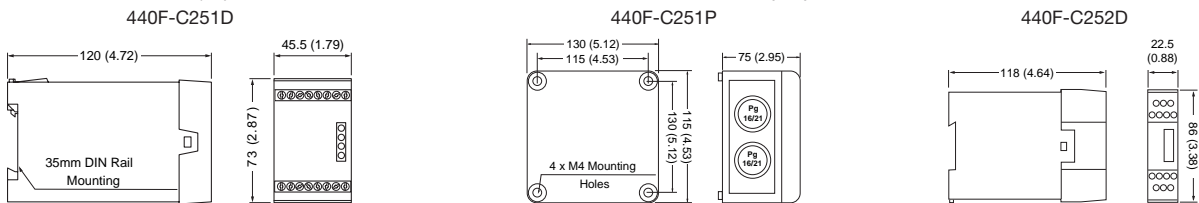

Typical Wiring Diagrams

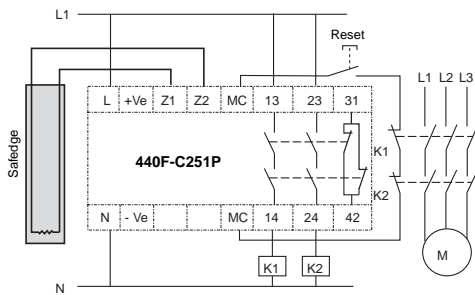

Series Terminated, Safedge Input, Manual Reset, Dual Channel Output, Monitored Output

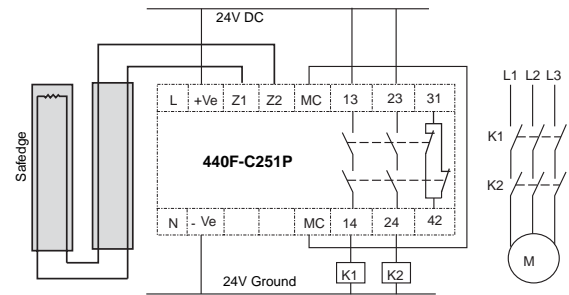

Series Terminated, Cascaded, Safedge Input, Automatic Reset, Dual Channel Output, No Output Monitored

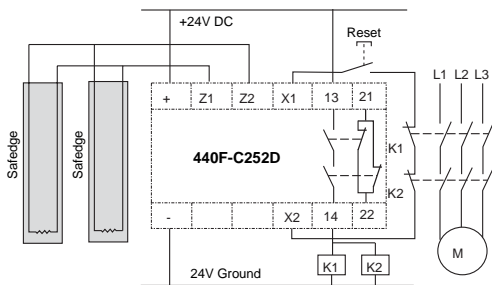

Parallel Terminated, Safedge Input, Manual Reset, Dual Channel Output, Monitored Output

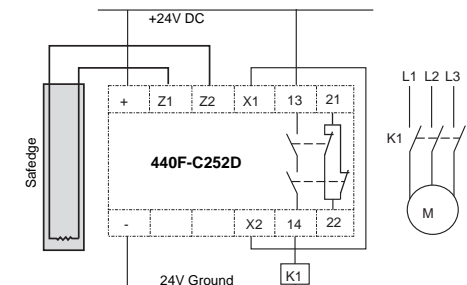

Series Terminated, Safedge Input, Automatic Reset, Single Channel Output, No Output Monitored

5-Safety Relays

# Logic Sipha Control Units



## Description

With the increasing speed and complexity of applications a simple magnetic switch may be insufficient to meet the increased risks, therefore Sipha's design incorporates several magnetically sensitive elements which must be triggered in a particular sequence to operate correctly. The Sipha sensor, designed to operate with its own actuator, helps prevent defeatability by a simple magnet.

The control unit is available in three types. The Sipha 1 control unit operates on 24V AC/DC and offers one normally open safety output and one normally closed solid-state auxiliary output. The Sipha 2 control unit operates on either 24V AC/DC, 110V AC or 230V AC and offers two normally open safety outputs and one normally closed auxiliary output. The Sipha 6 has wiring terminals for up to six sensors, a delayed output for Category 1 stops and offers the same wide range of power supply capability as the Sipha 2 control unit. Between two and six Sipha sensors can be directly connected to the Sipha 6 control unit. An internal DIP switch mutes the unused connections to sensors 1, 2, 3 and 4. This allows for individual monitoring to each interlock and provides enhanced safety integrity when compared to six interlocks running off a single Sipha 2 control unit.

The Sipha control units are designed to operate with the Sipha sensors and actuators. The controllers have automatic reset.

## Features

- Noncontact actuation
- Magnetic coded sensing
- Control unit acts as safety relay
- Four types of switches

## LED Indicators

Green LED	Power on
Green LED	Output Closed

## Application Details

See Sipha Sensors for details.

## Specifications

Safety Ratings	
Standards	EN954-1, ISO13849-1, IEC/EN60204-1, NFPA79, EN1088, ISO14119, IEC/EN60947-5-1, ANSI B11.19, AS4024.1
Safety Classification	Sipha 1 & 2: Cat. 3 per EN954-1 Sipha 6: Cat. 4 per EN954-1
Certifications	CE Marked for all applicable directives, cULus, and TÜV
Power Supply	
Input Power Entry	Sipha 1: 24V AC/DC; Sipha 2 & 6: 24V AC/DC and 115/230V AC
Power Consumption	Sipha 1: <2VA Sipha 2 & 6: <4VA
Inputs	
Safety Inputs	Sipha 1: 1 N.C. & 1 N.O. Sipha 2 & 6: 6 x (1 N.C. & 1 N.O.)
Input Resistance, Max.	Terminals 1...4: 200 Ω Terminals 2...3: 150 Ω
Outputs	
Safety Contacts	Sipha 1: 1 N.O. Sipha 2: 2 N.O. Sipha 6: 2 N.O. + 1 N.O. Delayed (0.6...30 sec.)
Auxiliary Contacts	1 N.C.
Rated Impulse withstand Voltage	2500V
Switching Current @ Voltage, Min.	10 mA @ 10V
Fuses, Output	External 5 A quick blow AC, 3 A quick blow DC
Electrical Life (Operations)	220V AC/4 A/880VA cosφ = 0.35...0.1 M 220V AC/1.7 A375VA cosφ = 0.6...0.5 M 30V DC/2 A/60 W = 1 M 10V DC/0.01 A/0.1 W = 2 M
Mechanical Life	2,000,000 operations
Environmental and Physical Characteristics	
Operating Temperature [C (F)]	-10...+55° (+14...+131°)
Vibration	1 mm, 10...55 Hz
Shock	30 g, 11 ms half-sine
Mounting	35 mm DIN Rail
Weight [g (lbs)]	Sipha 1: 140 (0.31) Sipha 2: 410 (0.90) Sipha 6: 675 (1.49)
Conductor Size, Max.	0.2...2.5 mm <sup>2</sup> (24...14 AWG)

- \* Usable for ISO 13849-1:2006 and IEC 62061. Data is based on the following assumptions:
- Mission time/Proof test interval of 20 years
  - Functional test at least once within six-month period

Product Selection

Housing	Supply Voltage	Safety Contacts	Auxiliary Contacts	Housing	Type	Cat. No.
	24V AC/DC	1 N.O.	1 N.C. Solid State	22.5 mm	Control Unit 1	440N-S32013
	24V AC/DC; 115/230V AC	2 N.O.	1 N.C.	45 mm	Control Unit 2	440N-S32021
	24V AC/DC; 115/230V AC	3 N.O. 1 N.O. Delayed	1 N.C.	90 mm	Sipha 6	440N-S32052

Accessories

Description	Cat. No.
Replacement Fuse, 500 mA	440R-A31562

Block Diagrams

Sipha 1

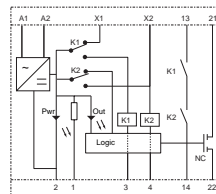

Sipha 2

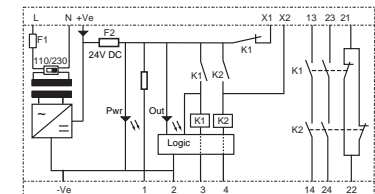

Approximate Dimensions

Dimensions are shown in mm (in.). Dimensions are not intended to be used for installation purposes.

Sipha Control Unit Type 1

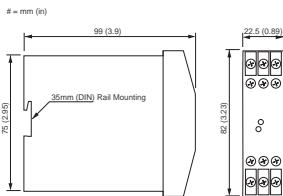

Sipha Control Unit Type 2

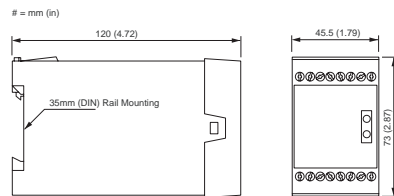

Sipha 6 Control Unit

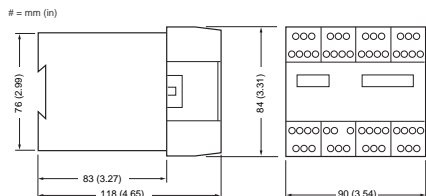

Typical Wiring Diagrams

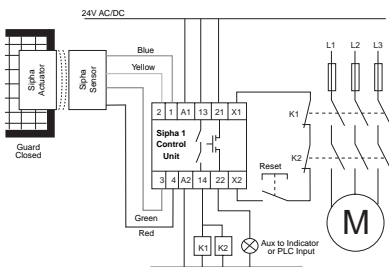

Single Sipha Sensor, 24V Supply, Dual Channel Output, Manual Reset, Monitored Output

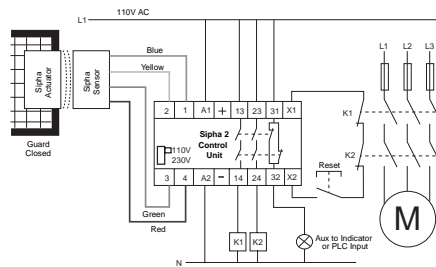

Single Sipha Sensor, 110V Supply, Dual Channel Output, Manual Reset, Monitored Output

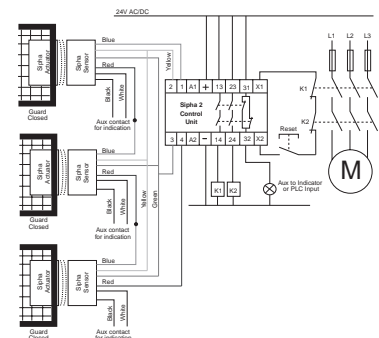

Multiple Sipha Sensor, Manual Reset, Dual Channel Output, Monitored Output

5-Safety Relays

# Expansion Safety Relays

## MSR45E



### Description

The MSR45E is a safety relay expansion module for the MSR41/MSR42 (MSR4x) multi-function safety controller. The MSR45E comes in 22.5 mm DIN housing and is designed to easily connect to the MSR4x. The MSR45E safety relay expansion module is a Category 4 module with externally monitored contactors via the MSR4x. Interconnecting these devices is as simple as plugging ribbon-cable connectors to the back of each module. Up to three MSR45E safety relay expansion modules may be interconnected to an MSR4x. The ribbon-cable connectors must be ordered separately based on the number of MSR45E units that are attached to the MSR4x.

### Features

- Category 4 per EN 954-1
- SIL CL3 per IEC 61508
- Stop category 0 or 1
- Two safety contacts N.O.

### LED Indicators

Green	K1 Closed
Green	K2 Closed

### Specifications

Safety Ratings	
Standards	EN 954-1, IEC/EN 60204-1, IEC 61496-1
Safety Classification	Cat. 4 per EN 954-1, SIL CL3 per EN IEC 61508
Functional Safety Data * <b>Note:</b> For up-to-date information, visit <a href="http://www.ab.com/Safety/">http://www.ab.com/Safety/</a>	PFH <sub>D</sub> : < 3.0E-10 MTTF <sub>d</sub> : > 206 years For use in SIL3 systems (according to IEC 62061) depending on the architecture and application characteristics
Certifications	CE Marked for all applicable directives, cULus, and TÜV
Power Supply	
Input Power Entry	24V DC from MSR41 or MSR42
Power Consumption	1.5 W
Inputs	
Reset	Determined by MSR41 or MSR42
Power On Delay/Recovery Time	<35 ms/ Determined by configuration
Response Time	Determined by configuration
Outputs	
Safety Contacts	2 N.O.
Auxiliary Contacts	—
Thermal Current <sub>I<sub>th</sub></sub>	1 x 8 A or 2 x 6 A nonswitching
Rated Impulse withstand Voltage <sub>I<sub>th</sub></sub>	—
Switching Current @ Voltage, Min.	10 mA @ 10V
Fuses, Output	External 6 A slow blow or 10 A fast acting
Mechanical Life	10,000,000 operations
Utilization Category	
Inductive: AC-15	3 A @ 250V AC
Inductive: DC-13	6 A @ 24V DC
Environmental and Physical Characteristics	
Enclosure Type Rating/ Terminal Protection	IP20/ IP20
Operating Temperature [C (F)]	0...55° (32...131°)
Vibration	10...55 Hz, 0.35 mm
Shock	10 g, 16 ms, 100 shocks
Mounting	35 mm DIN Rail
Weight [g (lbs)]	150 (0.33)
Conductor Size, Max.	1 x 2.5 mm <sup>2</sup> (14 AWG) stranded

- \* Usable for IEC 62061. Data is based on the following assumptions:  
 - Mission time/Proof test interval of 20 years  
 - Functional test at least once within six-month period

**Product Selection**

Inputs	Safety Outputs	Auxiliary Outputs	Time Delay	Terminals	Reset Type	Power Supply	Cat. No.
MSR4x base module	2	—	Software configurable through MSR4x	Removable	MSR4x base module defines reset type	24V DC from the base unit	<b>440R-P4NANS</b>

**Accessories**

Description	Cat. No.
Ribbon cable—for one MSR45E	<b>440R-ACABL1</b>
Ribbon cable—for two MSR45Es	<b>440R-ACABL2</b>
Ribbon cable—for three MSR45Es	<b>440R-ACABL3</b>
Replacement terminal block kit—MSR45E	<b>440R-ATERM2C</b>

**Approximate Dimensions**

Dimensions are shown in mm (in.). Dimensions are not intended to be used for installation purposes.

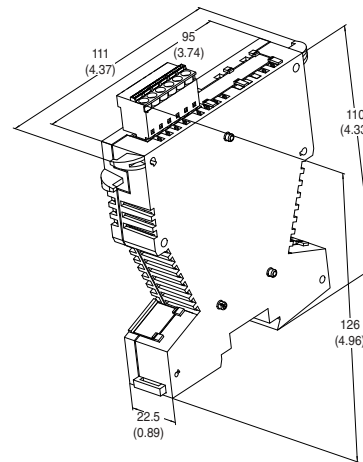

**Typical Wiring Diagrams**

**Hardware Configuration**

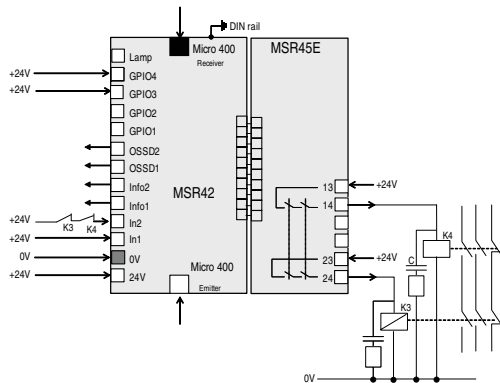

*Micro 400, Automatic Reset, Start/Restart Monitored Output*

**Software Configuration**

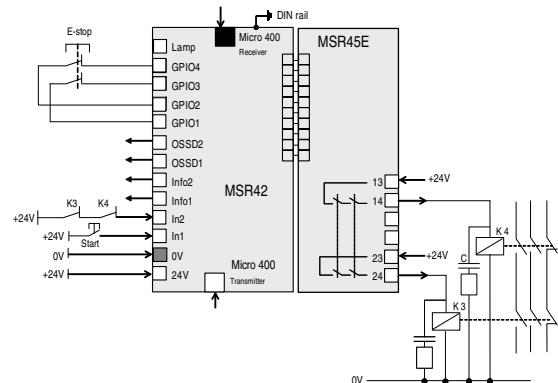

*Micro 400 Light Curtain, E-Stop, Manual Reset, Start/Restart Monitored Output*

**Hardware Configuration**

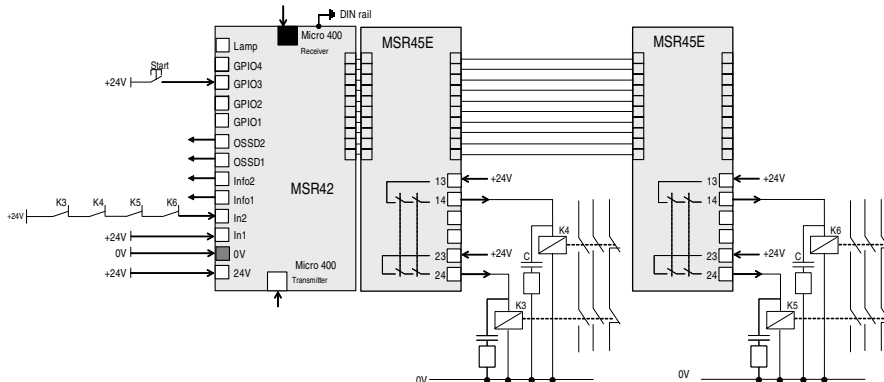

*Micro 400 Light Curtain, Manual Reset, Start/Restart Monitored Output*

## Expansion Safety Relays with Delayed Outputs

### MSR132E



#### Description

The Minotaur MSR132E is a monitoring safety expansion relay unit with single or dual channel input and either immediate or timed off-delay outputs. It is designed to be operated as an “extension” of a “master” safety relay. When wired properly, the outputs of the MSR132E will mimic the outputs of the master relay.

The outputs include four normally open safety rated outputs used to shut down the manufacturing system and two normally closed auxiliary outputs to indicate status of the MSR132E. One additional normally closed output is available to allow the host relay to monitor the status of the MSR132E. The safety, auxiliary and monitoring outputs have independent and redundant internal contacts to support the safety function.

A delayed output version is also available (MSR132ED) that have off-delayed outputs with a fixed time without the need for an auxiliary supply during the off-delay time.

#### Features

- Category 4/3 per EN 954-1
- Stop Category 0 or 1
- Four safety contacts N.O.
- Two auxiliary contacts N.C.
- One monitoring contact N.C.
- Single channel input

#### LED Indicators

Green	K1 Closed
Green	K2 Closed

#### Specifications

Safety Ratings	
Standards	EN 954-1, ISO 13849-1, IEC/EN 60204-1, IEC 60947-5-1, ANSI B11.19, AS 4024.1
Safety Classification	Cat. 4 per EN 954-1 (ISO 13849-1), SIL CL3 per EN IEC 62061, PLe per ISO 13849-1
Functional Safety Data * <b>Note:</b> For up-to-date information, visit <a href="http://www.ab.com/Safety/">http://www.ab.com/Safety/</a>	PFH <sub>D</sub> : < 0.46 x 10 <sup>-9</sup> MTTF <sub>D</sub> : > 417 years Suitable for performance levels Pl <sub>e</sub> (according to ISO 13849-1:2006) and for use in SIL3 systems (according to IEC 62061) depending on the architecture and application characteristics
Certifications	CE Marked for all applicable directives, cULus, c-Tick, and BG
Power Supply	
Input Power Entry	24V AC/DC 50/60 Hz or 24V DC 0.8...1.1
Power Consumption	1.5 W
Inputs	
Safety Inputs	1 N.C. or 2 N.C.
Reset	Automatic
Power On Delay/Recovery Time	100 ms/100 ms
Response Time	50 ms
Outputs	
Safety Contacts	4 N.O.
Auxiliary Contacts	2 N.C.
Thermal Current <sub>I<sub>th</sub></sub>	2 x 6 A or 3 x 5 A or 4 x 4 A nonswitching
Rated Impulse withstand Voltage <sub>I<sub>th</sub></sub>	2500V
Switching Current @ Voltage, Min.	10 mA @ 10V
Fuses, Output	External 6 A slow blow or 10 A fast acting
Electrical Life (Operations)	(With surge suppression) 250V AC/6 A/1500VA cosφ = 1...0.1 M 250V AC/2 A/500VA cosφ = 1...0.5 M 250V AC/4 A/1000VA cosφ = 0.35...0.3 M 250V AC/1.5 A/1000VA cosφ = 0.6...0.1 M 24V DC/2 A/48 W = 1 M 10V DC/0.01 A/0.1 W = 2 M
Mechanical Life	2,000,000 operations
Utilization Category	
Resistive: AC-1	6 A @ 250V AC
Resistive: DC-1	3 A @ 24V DC
Inductive: AC-15	6 A @ 250V AC      6 A @ 125V AC
Inductive: DC-13	3 A @ 24V DC
UL:	B300, R300, 6 A/250V AC, 3 A/24V DC
Environmental and Physical Characteristics	
Enclosure Type Rating/Terminal Protection	IP40 (NEMA 1), DIN 0470/ IP20, DIN 0470
Operating Temperature [C (F)]	-5...55° (23...131°)
Vibration	10...55 Hz, 0.35 mm
Shock	10 g, 16 ms, 100 shocks
Mounting	35 mm DIN Rail
Weight [g (lbs)]	215 (0.474)
Conductor Size, Max.	0.2...4 mm <sup>2</sup> (24...12 AWG)

- \* Usable for ISO 13849-1:2006 and IEC 62061. Data is based on the following assumptions:
- Mission time/Proof test interval of 20 years
  - Functional test at least once within six-month period

# Logic Expansion Safety Relays with Delayed Outputs MSR132E

## Product Selection

Inputs	Safety Outputs	Auxiliary Outputs	Time Delay	Terminals	Reset Type	Power Supply	Cat. No.			
1 N.C. or 2 N.C.	4 N.O.	2 N.C.	0 s	Fixed	Automatic	24V AC/DC	440R-E23191*			
			0.5 s				440R-E23192			
			1 s			440R-E23193				
			2 s			440R-E23194				
			3 s			440R-E23195				
			0 s	Removable		24V AC/DC	440R-E23097*			
			0.5 s				440R-E23159			
			1 s			440R-E23160				
			2 s			440R-E23098				
			3 s			440R-E23161				
						4 s			24V DC	440R-E23162*

\* Cat. 4 rated.  
\* 45 mm wide housing.

## Accessories

Description	Cat. No.
Bag of 4, 4-Pin Screw Terminal Blocks	440R-A23209
Bag of 4, 4-Pin Spring Clamp Terminal Blocks	440R-A23228

## Approximate Dimensions

Dimensions are shown in mm (in.). Dimensions are not intended to be used for installation purposes.

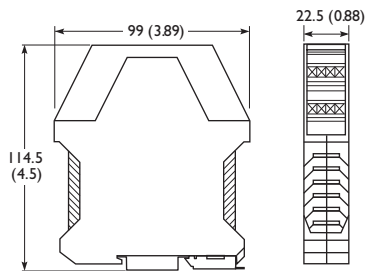

## Block Diagram

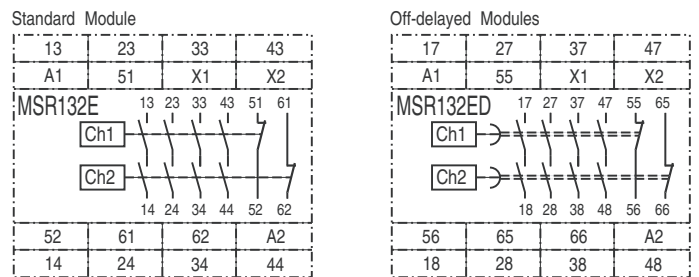

## Typical Wiring Diagrams

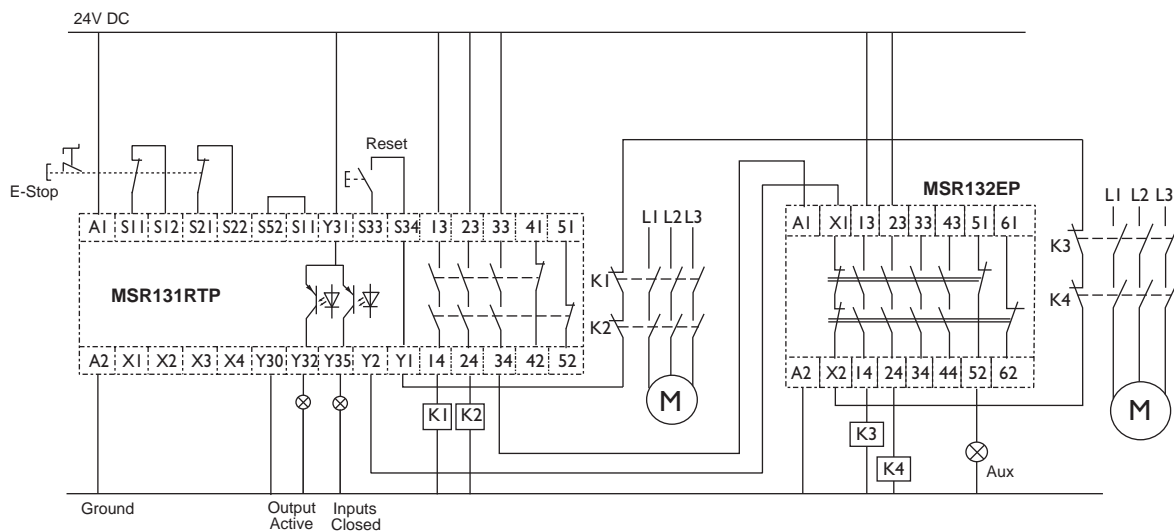

Dual Channel E-Stop, Monitored Manual Reset, Dual Channel Output, Single Channel Delayed Expansion, Monitored Output

5-Safety Relays

# Logic

## Modular Safety Relays

### Module Selection

#### Input Module Selection

To determine the base module and input modules needed, start on the left side and count down the number of OSSD input devices you have to connect to the system. Then move to the right according to the number of non-OSSD input devices you need, such as 1 N.C. or 2 N.C. input devices. Count the modules and this will be your total required for the system.

# of OSSD Inputs \ # of non-OSSD Devices	0	1	2	3	4	5	6	7	8	9	10	11	12	13	14	15	16	17	18	19	20	21	22
0	<b>MSR210</b>	MSR220	MSR220	MSR220	MSR220	MSR220	MSR220	MSR220	MSR220	MSR220	MSR220	MSR220	MSR220	MSR220	MSR220	MSR220	MSR220	MSR220	MSR220	MSR220	MSR220	MSR220	MSR220
1	<b>MSR211</b>	MSR220	MSR220	MSR220	MSR220	MSR220	MSR220	MSR220	MSR220	MSR220	MSR220	MSR220	MSR220	MSR220	MSR220	MSR220	MSR220	MSR220	MSR220	MSR220	MSR220	MSR220	MSR220
2	<b>MSR211</b>	MSR220	MSR220	MSR220	MSR220	MSR220	MSR220	MSR220	MSR220	MSR220	MSR220	MSR220	MSR220	MSR220	MSR220	MSR220	MSR220	MSR220	MSR220	MSR220	MSR220	MSR220	MSR220
3	<b>MSR221</b>	MSR220	MSR220	MSR220	MSR220	MSR220	MSR220	MSR220	MSR220	MSR220	MSR220	MSR220	MSR220	MSR220	MSR220	MSR220	MSR220	MSR220	MSR220	MSR220	MSR220	MSR220	MSR220
4	<b>MSR221</b>	MSR220	MSR220	MSR220	MSR220	MSR220	MSR220	MSR220	MSR220	MSR220	MSR220	MSR220	MSR220	MSR220	MSR220	MSR220	MSR220	MSR220	MSR220	MSR220	MSR220	MSR220	MSR220
5	<b>MSR221</b>	MSR220	MSR220	MSR220	MSR220	MSR220	MSR220	MSR220	MSR220	MSR220	MSR220	MSR220	MSR220	MSR220	MSR220	MSR220	MSR220	MSR220	MSR220	MSR220	MSR220	MSR220	MSR220
6	<b>MSR221</b>	MSR220	MSR220	MSR220	MSR220	MSR220	MSR220	MSR220	MSR220	MSR220	MSR220	MSR220	MSR220	MSR220	MSR220	MSR220	MSR220	MSR220	MSR220	MSR220	MSR220	MSR220	MSR220
7	<b>MSR221</b>	MSR220	MSR220	MSR220	MSR220	MSR220	MSR220	MSR220	MSR220	MSR220	MSR220	MSR220	MSR220	MSR220	MSR220	MSR220	MSR220	MSR220	MSR220	MSR220	MSR220	MSR220	MSR220
8	<b>MSR221</b>	MSR220	MSR220	MSR220	MSR220	MSR220	MSR220	MSR220	MSR220	MSR220	MSR220	MSR220	MSR220	MSR220	MSR220	MSR220	MSR220	MSR220	MSR220	MSR220	MSR220	MSR220	MSR220
9	<b>MSR221</b>	MSR220	MSR220	MSR220	MSR220	MSR220	MSR220	MSR220	MSR220	MSR220	MSR220	MSR220	MSR220	MSR220	MSR220	MSR220	MSR220	MSR220	MSR220	MSR220	MSR220	MSR220	MSR220
10	<b>MSR221</b>	MSR220	MSR220	MSR220	MSR220	MSR220	MSR220	MSR220	MSR220	MSR220	MSR220	MSR220	MSR220	MSR220	MSR220	MSR220	MSR220	MSR220	MSR220	MSR220	MSR220	MSR220	MSR220
11	<b>MSR221</b>	MSR220	MSR220	MSR220	MSR220	MSR220	MSR220	MSR220	MSR220	MSR220	MSR220	MSR220	MSR220	MSR220	MSR220	MSR220	MSR220	MSR220	MSR220	MSR220	MSR220	MSR220	MSR220
12	<b>MSR221</b>	MSR220	MSR220	MSR220	MSR220	MSR220	MSR220	MSR220	MSR220	MSR220	MSR220	MSR220	MSR220	MSR220	MSR220	MSR220	MSR220	MSR220	MSR220	MSR220	MSR220	MSR220	MSR220
13	<b>MSR221</b>	MSR220	MSR220	MSR220	MSR220	MSR220	MSR220	MSR220	MSR220	MSR220	MSR220	MSR220	MSR220	MSR220	MSR220	MSR220	MSR220	MSR220	MSR220	MSR220	MSR220	MSR220	MSR220
14	<b>MSR221</b>	MSR220	MSR220	MSR220	MSR220	MSR220	MSR220	MSR220	MSR220	MSR220	MSR220	MSR220	MSR220	MSR220	MSR220	MSR220	MSR220	MSR220	MSR220	MSR220	MSR220	MSR220	MSR220
15	<b>MSR221</b>	MSR220	MSR220	MSR220	MSR220	MSR220	MSR220	MSR220	MSR220	MSR220	MSR220	MSR220	MSR220	MSR220	MSR220	MSR220	MSR220	MSR220	MSR220	MSR220	MSR220	MSR220	MSR220
16	<b>MSR221</b>	MSR220	MSR220	MSR220	MSR220	MSR220	MSR220	MSR220	MSR220	MSR220	MSR220	MSR220	MSR220	MSR220	MSR220	MSR220	MSR220	MSR220	MSR220	MSR220	MSR220	MSR220	MSR220
17	<b>MSR221</b>	MSR220	MSR220	MSR220	MSR220	MSR220	MSR220	MSR220	MSR220	MSR220	MSR220	MSR220	MSR220	MSR220	MSR220	MSR220	MSR220	MSR220	MSR220	MSR220	MSR220	MSR220	MSR220
18	<b>MSR221</b>	MSR220	MSR220	MSR220	MSR220	MSR220	MSR220	MSR220	MSR220	MSR220	MSR220	MSR220	MSR220	MSR220	MSR220	MSR220	MSR220	MSR220	MSR220	MSR220	MSR220	MSR220	MSR220
19	<b>MSR221</b>	MSR220	MSR220	MSR220	MSR220	MSR220	MSR220	MSR220	MSR220	MSR220	MSR220	MSR220	MSR220	MSR220	MSR220	MSR220	MSR220	MSR220	MSR220	MSR220	MSR220	MSR220	MSR220
20	<b>MSR221</b>	MSR220	MSR220	MSR220	MSR220	MSR220	MSR220	MSR220	MSR220	MSR220	MSR220	MSR220	MSR220	MSR220	MSR220	MSR220	MSR220	MSR220	MSR220	MSR220	MSR220	MSR220	MSR220
21	<b>MSR221</b>	MSR220	MSR220	MSR220	MSR220	MSR220	MSR220	MSR220	MSR220	MSR220	MSR220	MSR220	MSR220	MSR220	MSR220	MSR220	MSR220	MSR220	MSR220	MSR220	MSR220	MSR220	MSR220
22	<b>MSR221</b>	MSR220	MSR220	MSR220	MSR220	MSR220	MSR220	MSR220	MSR220	MSR220	MSR220	MSR220	MSR220	MSR220	MSR220	MSR220	MSR220	MSR220	MSR220	MSR220	MSR220	MSR220	MSR220

5-Safety Relays



**Example 1:** 7 OSSD inputs and 5 non-OSSD inputs required.

**Solution:** MSR211, 3 MSR221, and 3 MSR220.



**Example 2:** 9 non-OSSD inputs required.

**Solution:** 1 MSR210 Base, 4 MSR220.

**Note:** This selection chart assumes that if you have OSSD input devices, they will be connected to the base module. If you do **not** want this, then change the MSR211 to the MSR210 and change one MSR220 to an MSR221. This will provide you the same system, but now the OSSD input device will not be on the base module.

**Output Module Selection**

Start at the top left and count the number of delayed outputs required. Then count across the number of immediate outputs required. Ensure you only have a total of two output modules total.

		Immediate										
		0	1	2	3	4	5	6	7	8	9	10
Delayed	0	MSR238	Base Unit				MSR230					MSR230
	1	MSR238	Base Unit				MSR230					
	2	MSR238	Base Unit				MSR230					
	3	MSR238	Base Unit				MSR230					
	4	MSR238	Base Unit				MSR230					

- ➔ **Example 1:** 2 Delayed outputs and 2 Immediate outputs  
**Solution:** (black lines) One MSR238, 2 Immediate outputs built in the base module
- ➔ **Example 2:** 5 Immediate outputs required  
**Solution:** (red line) 1 MSR230 Output module and 2 immediate outputs built into base module

**Note:** The base module has two N.O. safety outputs built in.

Logic  
**Modular Safety Relays**  
 MSR210P



**Description**

The MSR210P forms one of the base units for the modular Minotaur MSR200 family of monitoring safety relays. It can be combined with other modules of the MSR200 Series to configure a safety control system with numbers of inputs and outputs matching users' specific application requirements, as well as diagnostic and networking capabilities. Up to ten input modules and two output modules can be connected to one base unit by simply removing the terminator, included with each base unit, and connecting the ribbon cables of the neighboring module. The terminators must be inserted into the final input and output modules.

The MSR210P has two inputs. Each input can be wired in one of four ways: one normally closed, two normally closed, three normally closed, safety mat connections. The MSR210P uses pulsed input monitoring to check for faults to power, ground or between inputs before a demand is placed on the safety system. Connecting a single device (must be at least dual channel) to each input meets the requirements of Category 4 per EN 954-1.

The MSR210P has the capability to perform external device monitoring (EDM). The EDM capability works in conjunction with the reset option. The user selects EDM and the reset function by jumpers across terminals Y40, Y41 and Y42.

The MSR210P has two semiconductor outputs designed to send status information to a PLC. Terminal Y33 indicates the inputs are closed (the ready LED is on). Terminal Y32 indicates the outputs are active.

The outputs include two normally open safety rated outputs and one normally closed auxiliary output.

**Features**

- Category 4 per EN 954-1
- Stop category 0
- Pulsed input monitoring
- Two input circuits: safety gate, E-stop or safety mat
- Up to 22 diverse input devices
- Two safety outputs, three auxiliary outputs
- Ten diagnostic LEDs
- Removable terminals

**LED Indicators**

Green	Input 1 Closed
Red	Input 1 Open
Green	Input 2 Closed
Red	Input 2 Open
Green	CH1 Output Active
Green	CH2 Output Active
Green	Power
Green	Run (Outputs Active)
Red	Stop (Outputs Off) + Diagnostics
Amber	Ready (Inputs Closed)

**Specifications**

Safety Ratings	
Standards	EN 954-1, ISO 13849-1, IEC/EN 60204-1, IEC 60947-4-1, IEC 60947-5-1, ANSI 11.19, AS 4024.1
Safety Classification	Cat. 4 per EN 954-1 (ISO 13849-1), SIL CL3 per EN IEC 62061, PLe per ISO 13849-1
Functional Safety Data * Note: For up-to-date information, visit <a href="http://www.ab.com/Safety/">http://www.ab.com/Safety/</a>	PFHD: < 3.44 x 10 <sup>-9</sup> MTTFd: > 203 years Suitable for performance levels PLe (according to ISO 13849-1:2006) and for use in SIL3 systems (according to IEC 62061) depending on the architecture and application characteristics
Certifications	CE Marked for all applicable directives, cULus, c-Tick, and TÜV

Power Supply	
Input Power Entry	24V DC 0.8...1.1 x rated voltage
Power Consumption	8 W

Inputs	
Safety Inputs	1 N.C., 2 N.C., 3 N.C., or SM
Input Simultaneity	Infinite
Input Resistance, Max.	Inputs: 900 Ω Reset: 3200 Ω
Reset	Auto./Manual or Monitored Manual
Power On Delay/Recovery Time	3 seconds/ 40...145 ms, depending on expansion modules used
Response Time	MSR210: 29 ms MSR210 + Input Exp. Mod.: 34 ms + 6 ms/module

Outputs	
Safety Contacts	2 N.O.
Auxiliary Contacts	1 N.C., 2 PNP
Thermal Current/ <i>I<sub>th</sub></i>	1 x 6 A or 2 x 4 A (nonswitching)
Rated Impulse withstand Voltage	2500V
Switching Current @ Voltage, Min.	10 mA @ 10V DC
Fuses, Output	External 6 A slow blow or 10 A fast acting
Solid State Output Rating	20 mA @ 30V DC short-circuit protection
Electrical Life (Operations)	(With surge suppression) 250V AC/6 A/1500VA cosφ = 1...0.1 M 250V AC/2 A/500VA cosφ = 1...0.5 M 250V AC/4 A/1000VA cosφ = 0.35...0.3 M 250V AC/1.5 A/1000VA cosφ = 0.6...0.1 M 24V DC/2 A/48 W = 1 M 10V DC/0.01 A/0.1 W = 2 M
Mechanical Life	2,000,000 cycles

Utilization Category		
Inductive: AC-15	3 A @ 250V AC	3 A @ 125V AC
Inductive: DC-13	2.5 A @ 24V DC	
UL	1 x B300, R300, or 2 x C300 1 x 6 A or 2 x 4 A Resistive	

Environmental and Physical Characteristics	
Enclosure Type Rating/ Terminal Protection	IP40 (NEMA 1)/ IP20
Operating Temperature [C (F)]	-5...+55 ° (23...131 °)
Vibration	10...55 Hz, 0.35 mm
Shock	10 g, 16 ms, 100 shocks
Mounting	45 mm housing, 35 mm DIN Rail
Weight [g (lb)]	280 (0.62)
Conductor Size, Max.	0.2...4 mm <sup>2</sup> (24...12 AWG)

\* Usable for ISO 13849-1:2006 and IEC 62061. Data is based on the following assumptions:  
 - Mission time/Proof test interval of 20 years  
 - Functional test at least once within six-month period

**Product Selection**

Inputs	Safety Outputs	Auxiliary Outputs	Solid State Outputs	Terminals	Reset Type	Power Supply	Cat. No.
Two independent inputs; 2 x 1 N.C., 2 N.C., 3 N.C., or Safety Mat	2 N.O.	1 N.C. and 2 PNP Solid State	2 PNP	Removable	Auto./Manual or Monitored Manual	24V DC from the base unit	440R-H23176

**Accessories**

Description	Cat. No.
MSR200, Two Terminators	440R-A17138
Bag of 4, 4-Pin Screw Terminal Blocks	440R-A23209
Bag of 4, 4-Pin Spring Clamp Terminal Blocks	440R-A23228

**Diagnostics—Red Stop LED Blinks**

Blink Rate	Description
2	Change in Y40/Y41/Y42 circuit during operation.
3	Fault in external feedback circuit Y1-Y2. Clear fault and cycle power to reset the module.
Continuous	Internal fault in base or expansion module.

**Approximate Dimensions**

Dimensions are shown in mm (in.). Dimensions are not intended to be used for installation purposes.

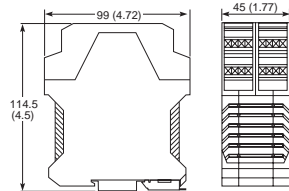

**Block Diagram**

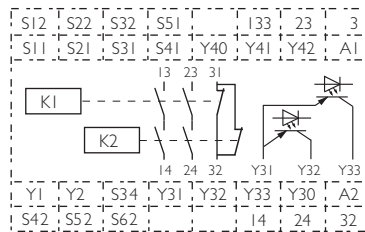

**Typical Wiring Diagrams**

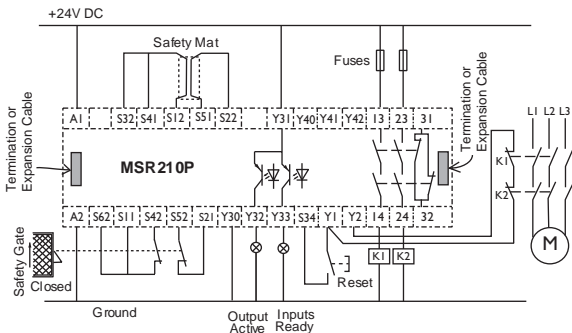

**Safety Mat and Dual Channel Safety Gate, Monitored Manual Reset, Monitored Output**

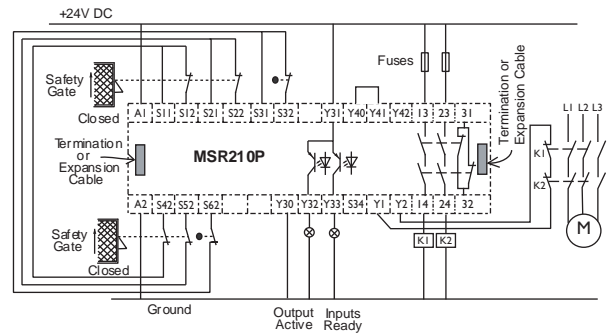

**Two Triple Channel Inputs, Automatic Reset, Monitored Output**

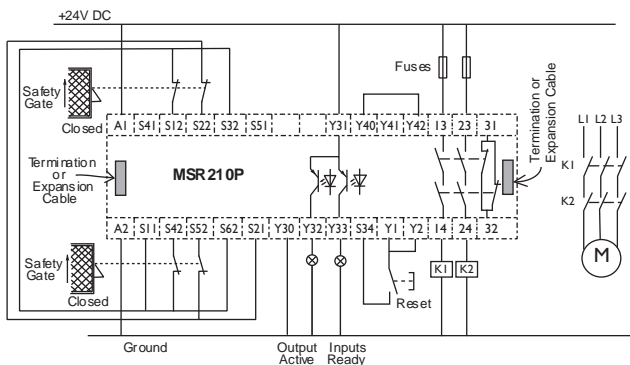

**Two Dual Channel Safety Gates, Monitored Manual Reset, No Monitored Output**

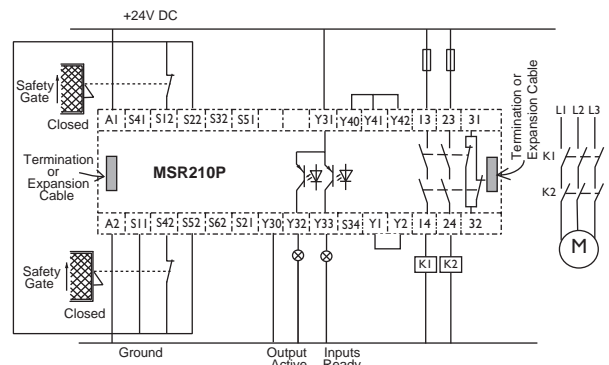

**Two Single Channel Safety Gates, Automatic Reset, No Monitored Output**

**5-Safety Relays**

Logic  
**Modular Safety Relays**  
 MSR211P



**Description**

The MSR211P forms one of the base units for the modular Minotaur MSR200 family of monitoring safety relays. It can be combined with other modules of the MSR200 Series to configure a safety control system with numbers of inputs and outputs matching users' specific application requirements, as well as diagnostic and networking capabilities. Up to ten input modules and two output modules can be connected to one base unit by simply removing the terminator, included with each base unit, and connecting the ribbon cables of the neighboring module. The terminators must be inserted into the final input and output modules.

The MSR211P has two inputs. Each input can be wired in one of three ways: one normally closed, two normally closed, or two OSSD connections from a light curtain. The MSR211P does not perform cross fault monitoring, and would not detect a short across the inputs of a two normally closed input. When connected to light curtains, the light curtain must perform the cross fault detection.

The MSR211P has the capability to perform external device monitoring (EDM). The EDM capability works in conjunction with the reset option. The user selects EDM and the reset function by jumpers across terminals Y40, Y41 and Y42.

The MSR211P has two semiconductor outputs designed to send status information to a PLC. Terminal Y33 indicates the inputs are closed (the ready LED is on). Terminal Y32 indicates the outputs are active.

The outputs include two normally open safety rated outputs and one normally closed auxiliary output.

**Features**

- Category 4 per EN 954-1
- Stop category 0
- Two input circuits: light curtain, safety gate, or E-stop inputs
- Two safety outputs, three auxiliary outputs
- Ten diagnostic LEDs
- Monitored or automatic reset
- Removable terminals

**LED Indicators**

Green	Input 1 Closed
Red	Input 1 Open
Green	Input 2 Closed
Red	Input 2 Open
Green	CH1 Output Active
Green	CH2 Output Active
Green	Power
Green	Run (Outputs Active)
Red	Stop (Outputs Off) + Diagnostics
Amber	Ready (Inputs Closed)

**Specifications**

Safety Ratings		
Standards	EN 954-1, ISO 13849-1, IEC/EN 60204-1, IEC 60947-4-1, IEC 60947-5-1, ANSI 11.19, AS 4024.1	
Safety Classification	Cat. 4 per EN 954-1 (ISO 13849-1), SIL CL3 per EN IEC 62061, PLe per ISO 13849-1	
Functional Safety Data * Note: For up-to-date information, visit <a href="http://www.ab.com/Safety/">http://www.ab.com/Safety/</a>	PFH <sub>D</sub> : < 3.49 x 10 <sup>-9</sup> MTTF <sub>d</sub> : > 188 years Suitable for performance levels PLe (according to ISO 13849-1:2006) and for use in SIL3 systems (according to IEC 62061) depending on the architecture and application characteristics	
Certifications	CE Marked for all applicable directives, cULus, c-Tick, and TÜV	
Power Supply		
Input Power Entry	24V DC 0.8...1.1 x rated voltage	
Power Consumption	8 W	
Inputs		
Safety Inputs	Two Inputs 1 N.C. or 2 N.C. or LC	
Input Simultaneity	Infinite	
Input Resistance, Max.	Inputs: 900 Ω Reset: 3200 Ω	
Reset	Auto./Manual or Monitored Manual	
Power On Delay/ Recovery Time	3 seconds/40...145 ms, depending on expansion modules used	
Response Time	MSR211: 25 ms MSR211+ MSR221.: 30 ms+2.4 ms per MSR221	
Outputs		
Safety Contacts	2 N.O.	
Auxiliary Contacts	1 N.C., 2 PNP	
Thermal Current <sub>I<sub>th</sub></sub>	1 x 6 A or 2 x 4 A (nonswitching)	
Rated Impulse withstand Voltage <sub>U<sub>th</sub></sub>	2500V	
Switching Current @ Voltage, Min.	10 mA @ 10V DC	
Fuses, Output	External 6 A slow blow or 10 A quick blow	
Solid State Output Rating	20 mA @ 30V DC short-circuit protection	
Electrical Life (Operations)	220V AC/4 A/880VA cosφ = 0.35...0.1 M 220V AC/1.7 A375VA cosφ = 0.6...0.5 M 30V DC/2 A/60 W = 1 M 10V DC/0.01 A/0.1 W = 2 M	
Mechanical Life	2,000,000 cycles	
Utilization Category		
Resistive: AC-1	6 A @ 250V AC	
Resistive: DC-1	6 A @ 24V DC	
Inductive: AC-15	3 A @ 250V AC B300	3 A @ 125V AC
Inductive: DC-13	2.5 A @ 24V DC	
UL	1 x B300, R300 or 2 x C300 1 x 6 A or 2 x 4 A Resistive	
Environmental and Physical Characteristics		
Enclosure Type Rating/ Terminal Protection	IP40 (NEMA 1)/ IP20	
Operating Temperature [C (F)]	-5...+55 ° (23...131 °)	
Vibration	10...55 Hz, 0.35 mm	
Shock	10 g, 16 ms, 100 shocks	
Mounting	35 mm DIN Rail	
Weight [g (lbs)]	280 (0.62)	
Conductor Size, Max.	0.2...4 mm <sup>2</sup> (24...12 AWG)	

\* Usable for ISO 13849-1:2006 and IEC 62061. Data is based on the following assumptions:  
 - Mission time/Proof test interval of 20 years  
 - Functional test at least once within six-month period

**Product Selection**

Inputs	Safety Outputs	Auxiliary Outputs	Solid State Outputs	Terminals	Reset Type	Power Supply	Cat. No.
Two independent inputs; 2 x 1 N.C., 2 N.C., or Light Curtain	2 N.O.	1 N.C.	2 PNP	Removable	Auto./Manual or Monitored Manual	24V DC from the base unit	440R-H23177

**Accessories**

Description	Cat. No.
MSR200, Two Terminators	440R-A17138
Bag of 4, 4-Pin Screw Terminal Blocks	440R-A23209
Bag of 4, 4-Pin Spring Clamp Terminal Blocks	440R-A23228

**Diagnostics—Red Stop LED Blinks**

Blink Rate	Description
2	Change in Y40/Y41/Y42 circuit during operation.
3	Fault in external feedback circuit Y1-Y2. Clear fault and cycle power to reset the module.
Continuous	Internal fault in base or expansion module.

**Approximate Dimensions**

Dimensions are shown in mm (in.). Dimensions are not intended to be used for installation purposes.

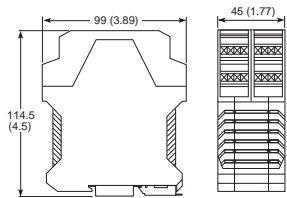

**Block Diagram**

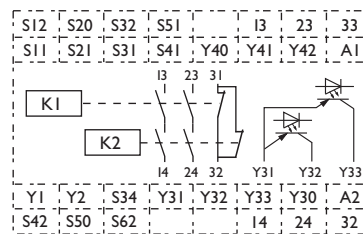

**Typical Wiring Diagrams**

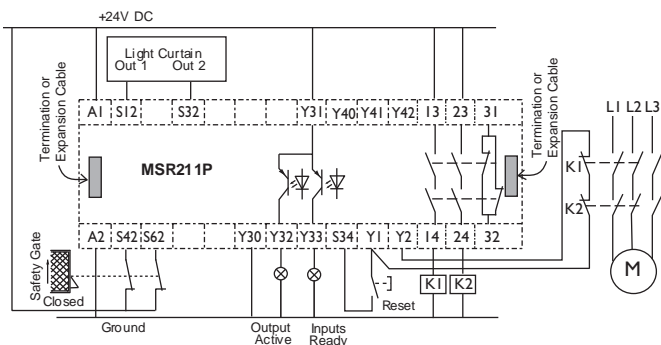

**Light Curtain and Dual Channel Safety Gate, Monitored Manual Reset, Monitored Output**

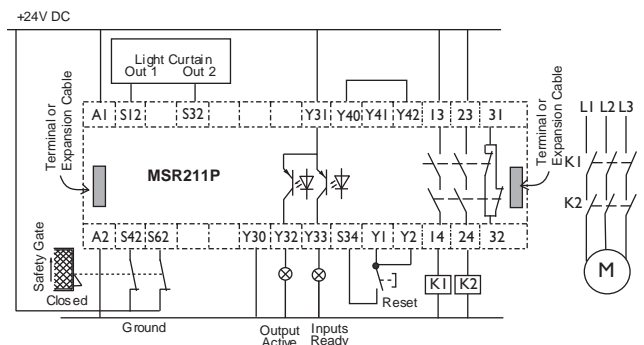

**Light Curtain and Dual Channel Safety Gate, Monitored Manual Reset, No Monitored Output**

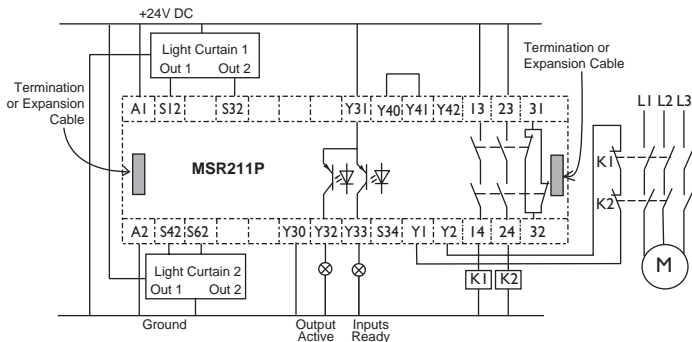

**Two Light Curtains, Automatic Reset, Monitored Output**

Logic  
**Modular Safety Relays**  
 MSR220P



**Description**

The MSR220P is an input expansion module for the modular Minotaur MSR200 family of monitoring safety relays. It can be connected to either the MSR210P or MSR211P to provide additional inputs.

Up to ten input modules can be connected to a base unit by simply removing the terminator, included with each base unit, and connecting the ribbon cables of the neighboring module. The connecting ribbon cable provides power to the MSR220P as well as a check on its status. The terminators must be inserted into the final output module. The input modules to a base unit can be either MSR220P or MSR221P in any combination or order.

The MSR220P has two independent inputs, which can be wired in one of five ways: one normally closed, two normally closed, three normally closed, one normally closed and one normally open or a safety mat. When used with the MSR210 base unit, the inputs to the MSR220 are continuously pulse-checked for shorts to power, ground and across inputs. Connecting a single device (must be at least dual channel) to each input meets the requirements of Category 4 per EN 594-1.

Four LEDs provide status information on the inputs. Green indicates the input is closed and red indicates the input is open.

**Features**

- Category 4 per EN 954-1
- Stop category 0
- 17.5 mm DIN Rail housing
- Two input circuits: safety gate, E-stop or safety mat
- Four diagnostic LEDs
- Removable terminals

**LED Indicators**

Green	Input 1 Closed
Red	Input 1 Open
Green	Input 2 Closed
Red	Input 2 Open

**Specifications**

Safety Ratings	
Standards	EN 954-1, ISO 13849-1, IEC/EN 60204-1, IEC 60947-4-1, IEC 60947-5-1, ANSI 11.19, AS4024.1
Safety Classification	Cat. 4 per EN 954-1 (ISO 13849-1), SIL CL3 per EN IEC 62061, PLe per ISO 13849-1
Functional Safety Data * <b>Note:</b> For up-to-date information, visit <a href="http://www.ab.com/Safety/">http://www.ab.com/Safety/</a>	PFH <sub>D</sub> : < 3.7 x 10 <sup>-10</sup> MTTFd: > 825 years Suitable for performance levels PLe (according to ISO 13849-1:2006) and for use in SIL3 systems (according to IEC 62061) depending on the architecture and application characteristics
Certifications	CE Marked for all applicable directives, cULus, c-Tick, and BG
Power Supply	
Input Power Entry	24V DC from the base unit
Power Consumption	2 W
Inputs	
Safety Inputs	1 N.C. or 2 N.C. or 3 N.C. or 1 N.C. + 1 N.O. or SM
Input Simultaneity	Infinite
Input Resistance, Max.	900 Ω
Reset	See base unit
Power On Delay/ Recovery Time	See base unit
Response Time	See base unit
Environmental and Physical Characteristics	
Enclosure Type Rating/ Terminal Protection	IP40 (NEMA 1)/ IP20
Operating Temperature [C (F)]	-5...+55 ° (23...131 °)
Vibration	10...55 Hz, 0.35 mm
Shock	10 g, 16 ms, 100 shocks
Mounting	17.5 mm housing, 35 mm DIN Rail
Weight [g (lbs)]	90 (0.20)
Conductor Size, Max.	0.2...4 mm <sup>2</sup> (24...12 AWG)

\* Usable for ISO 13849-1:2006 and IEC 62061. Data is based on the following assumptions:  
 - Mission time/Proof test interval of 20 years  
 - Functional test at least once within six-month period

**Product Selection**

Inputs	Auxiliary Outputs	Terminals	Reset Type	Power Supply	Cat. No.
Two Independent Inputs: 1 N.C., 2 N.C., 3 N.C., 1 N.C. + 1 N.O., or SM	—	Removable	—	24V DC	440R-H23178

**Accessories**

Description	Cat. No.
Bag of 4, 3-Pin Screw Terminal Blocks	440R-A23210
Bag of 4, 3-Pin Spring Clamp Terminal Blocks	440R-A23229

**Approximate Dimensions**

Dimensions are shown in mm (in.). Dimensions are not intended to be used for installation purposes.

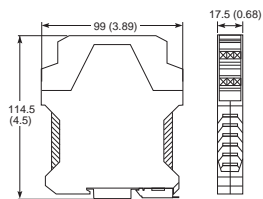

**Block Diagram**

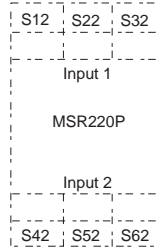

**Typical Wiring Diagrams**

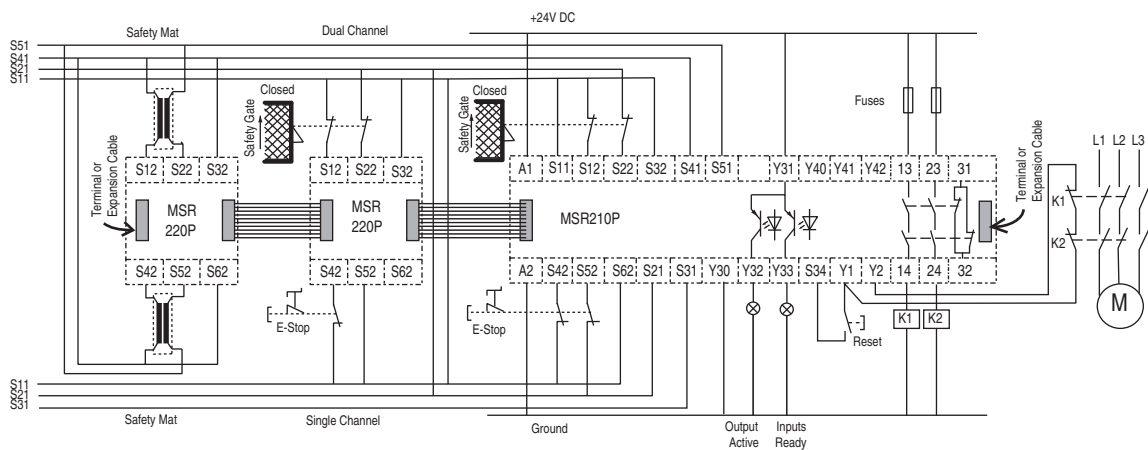

**MSR220P Expanding an MSR210P**

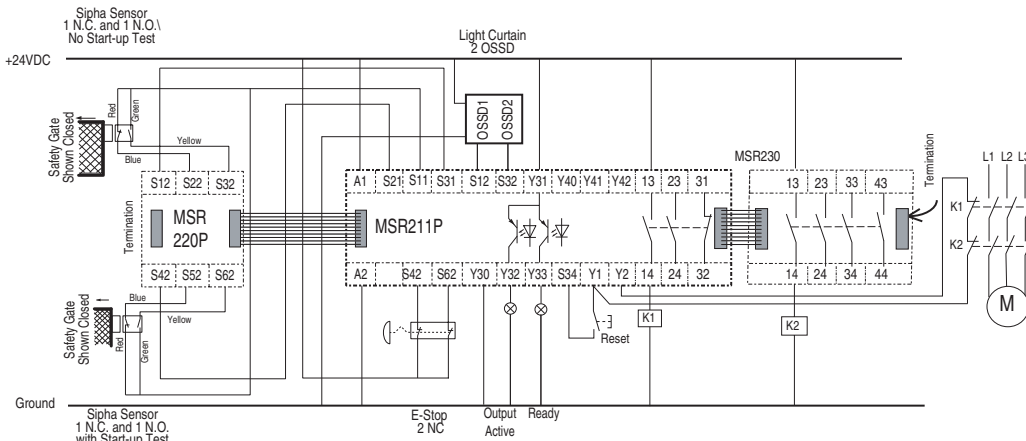

**MSR220P Expanding an MSR211P**

**5-Safety Relays**

# Modular Safety Relays

## MSR221P



### Description

The MSR221P is an input expansion module for the modular Minotaur MSR200 family of monitoring safety relays. It can be connected to either the MSR210P or MSR211P to provide additional inputs.

Up to ten input modules can be connected to a base unit by simply removing the terminator, included with each base unit, and connecting the ribbon cables of the neighboring module. The connecting ribbon cable provides power to the MSR220P as well as a check on its status. The terminators must be inserted into the final output module. The input modules to a base unit can be either MSR220P or MSR221P in any combination or order.

The MSR221P has two independent inputs, which can be wired in one of three ways: one normally closed, two normally closed, or a light curtain. When connected in the two normally closed configuration, the MSR221P does not perform cross fault monitoring (i.e., checks for shorts between the two inputs).

Four LEDs provide status information on the inputs. Green indicates the input is closed and red indicates the input is open.

### Features

- 17.5 mm DIN Rail housing
- Two input circuits: gate, E-stop or light curtains
- Four diagnostic LEDs
- Removable terminals

### LED Indicators

Green	Input 1 Closed
Red	Input 1 Open
Green	Input 2 Closed
Red	Input 2 Open

### Specifications

Safety Ratings	
Standards	IEC/EN 60204-1, ISOTR 121100, ISO 13849-1 (EN 954-1), B11.19, AS 4024.1
Safety Classification	Cat. 4 per EN 954-1 (ISO 13849-1), SIL CL3 per EN IEC 62061, PLe per ISO 13849-1
Functional Safety Data * <b>Note:</b> For up-to-date information, visit <a href="http://www.ab.com/Safety/">http://www.ab.com/Safety/</a>	PFH <sub>D</sub> : < 3.7 x 10 <sup>-10</sup> MTTF <sub>d</sub> : > 825 years Suitable for performance levels Pl <sub>e</sub> (according to ISO 13849-1:2006) and for use in SIL3 systems (according to IEC 62061) depending on the architecture and application characteristics
Certifications	CE Marked for all applicable directives, cULus, c-Tick, and TÜV
Power Supply	
Input Power Entry	24V DC from the base unit
Power Consumption	2 W
Inputs	
Safety Inputs	1 N.C. or 2 N.C. or LC
Input Simultaneity	Infinite
Input Resistance, Max.	1300 Ω
Reset	See base unit
Power On Delay/Recovery Time	See base unit
Response Time	See base unit
Environmental and Physical Characteristics	
Enclosure Type Rating/Terminal Protection	IP40 (NEMA 1)/IP20
Operating Temperature [C (F)]	-5...+55 ° (23...131 °)
Vibration	10...55 Hz, 0.35 mm
Shock	10 g, 16 ms, 100 shocks
Mounting	35 mm DIN Rail
Weight [g (lbs)]	90 (0.20)
Conductor Size, Max.	0.2...4 mm <sup>2</sup> (24...12 AWG)

- \* Usable for ISO 13849-1:2006 and IEC 62061. Data is based on the following assumptions:
- Mission time/Proof test interval of 20 years
  - Functional test at least once within six-month period

**Product Selection**

Inputs	Safety Outputs	Auxiliary Outputs	Terminals	Reset Type	Power Supply	Cat. No.
Two Independent Inputs: 1 N.C., 2 N.C., or LC	—	—	Removable	—	24V DC from the base unit	440R-H23179

**Accessories**

Description	Cat. No.
Bag of 4, 3-Pin Screw Terminal Blocks	440R-A23210
Bag of 4, 3-Pin Spring Clamp Terminal Blocks	440R-A23229

**Approximate Dimensions**

Dimensions are shown in mm (in.). Dimensions are not intended to be used for installation purposes.

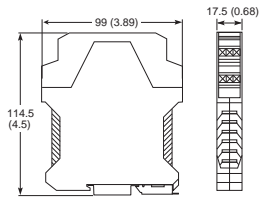

**Block Diagram**

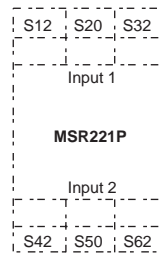

**Typical Wiring Diagrams**

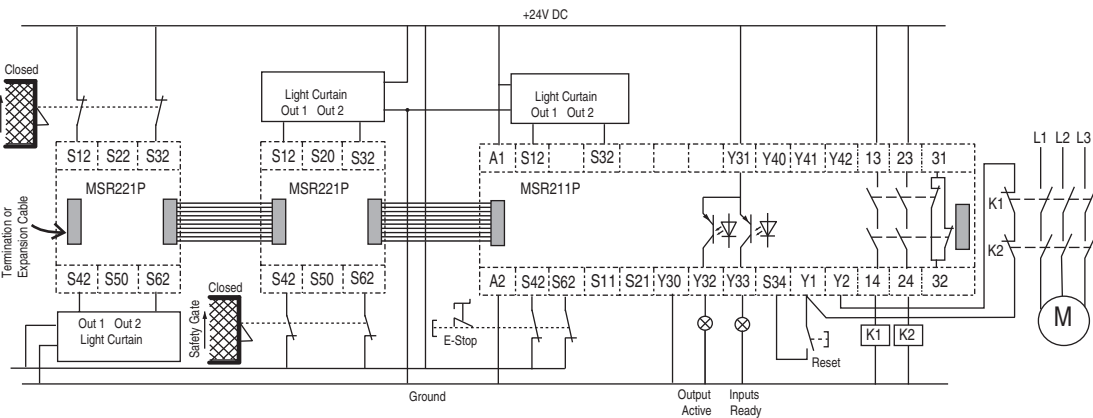

**Light Curtain, Safety Gate, E-Stop, Monitored Manual Reset, Monitored Output**

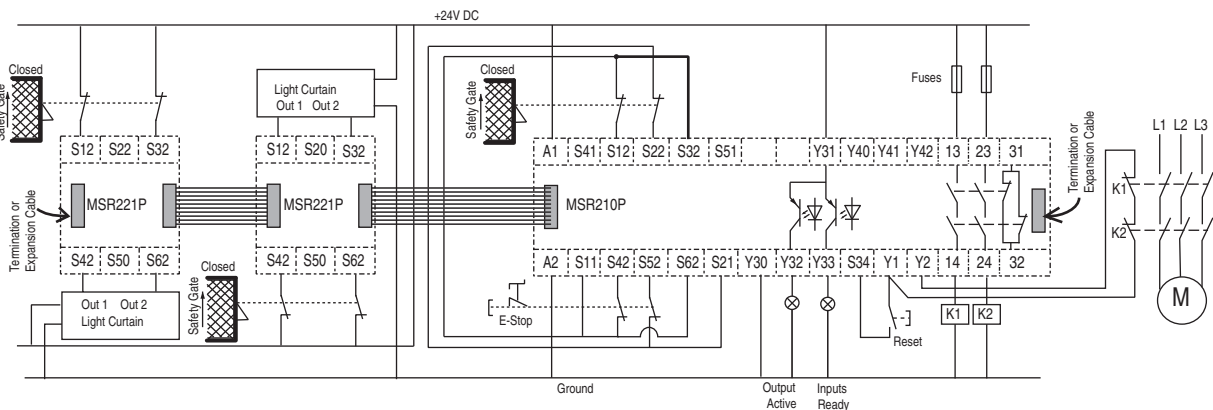

**Light Curtain, Dual Channel Safety Gates and E-Stop, Monitored Manual Reset, Monitored Output**

Logic  
**Modular Safety Relays**  
 MSR230P



**Description**

The MSR230P is an output expansion module for the modular Minotaur MSR200 family of monitoring safety relays. It can be connected to either the MSR210P or MSR211P base unit to provide additional outputs.

Up to two MSR230P output modules can be connected to one base unit by simply removing the terminator, included with each base unit, and connecting the ribbon cables of the neighboring module. The connecting ribbon cable provides power to the MSR230P as well as a check on its status. The terminators must be inserted into the final output module.

The MSR230P has four safety rated outputs that work in parallel with the safety outputs of the base unit. When the output of the base unit is activated, the outputs of the MSR230P are also activated.

The outputs are four normally open safety rated outputs. The safety outputs have independent and redundant internal contacts to help support the safety function.

**Features**

- Four N.O. safety outputs
- Two diagnostic LEDs
- Removable terminals

**LED Indicators**

Green	Channel 1 Output ON
Red	Channel 1 Output OFF
Green	Channel 2 Output ON
Red	Channel 2 Output OFF

**Specifications**

Safety Ratings		
Standards	EN 954-1, ISO 13849-1, IEC/EN 60204-1, IEC 60947-4-1, IEC 60947-5-1, ANSI 11.19, AS 4024.1	
Safety Classification	Cat. 4 per EN 954-1 (ISO 13849-1), SIL CL3 per EN IEC 62061, PLe per ISO 13849-1	
Functional Safety Data * <b>Note:</b> For up-to-date information, visit <a href="http://www.ab.com/Safety/">http://www.ab.com/Safety/</a>	PFH <sub>D</sub> : < 2.3 x 10 <sup>-10</sup> MTTFd: > 454 years Suitable for performance levels PLe (according to ISO 13849-1:2006) and for use in SIL3 systems (according to IEC 62061) depending on the architecture and application characteristics	
Certifications	CE Marked for all applicable directives, cULus, c-Tick, and TÜV	
Power Supply		
Input Power Entry	24V DC from the base unit	
Power Consumption	1.5 W	
Inputs		
Response Time	Does not add additional response time to base module	
Outputs		
Safety Contacts	4 N.O.	
Thermal Current <sub>I<sub>th</sub></sub>	2 x 6 A or 3 x 5 A or 4 x 4 A (nonswitching)	
Rated Impulse withstand Voltage	2500V	
Switching Current @ Voltage, Min.	10 mA @ 10V DC	
Fuses, Output	External 6 A slow blow or 10 A fast acting	
Electrical Life (Operations)	220V AC/4 A/880VA cosφ = 0.35...0.1 M 220V AC/1.7 A375VA cosφ = 0.6...0.5 M 30V DC/2 A/60 W = 1 M 10V DC/0.01 A/0.1 W = 2 M	
Mechanical Life	2,000,000 cycles	
Utilization Category		
Resistive: AC-1	6 A @ 250V AC	
Resistive: DC-1	6 A @ 24V DC	
Inductive: AC-15	3 A @ 250V AC	3 A @ 125V AC
Inductive: DC-13	2.5 A @ 24V DC	
UL	3 x B300, P300 or 4 x C300 2 x 6 A or 3 x 5 A or 4 x 4 A Resistive	
Environmental and Physical Characteristics		
Enclosure Type Rating/ Terminal Protection	IP40 (NEMA 1)/ IP20	
Operating Temperature [C (F)]	-5...+55 ° (23...131 °)	
Vibration	10...55 Hz, 0.35 mm	
Shock	10 g, 16 ms, 100 shocks	
Mounting	35 mm DIN Rail	
Weight [g (lbs)]	215 (0.47)	
Conductor Size, Max.	0.2...4 mm <sup>2</sup> (24...12 AWG)	

\* Usable for ISO 13849-1:2006 and IEC 62061. Data is based on the following assumptions:  
 - Mission time/Proof test interval of 20 years  
 - Functional test at least once within six-month period

**Product Selection**

Inputs	Safety Outputs	Auxiliary Outputs	Terminals	Reset Type	Power Supply	Cat. No.
NA	4 N.O.	—	Removable	—	24V DC from the base unit (terminals only)	440R-H23180

**Accessories**

Description	Cat. No.
Bag of 4, 4-Pin Screw Terminal Blocks	440R-A23209
Bag of 4, 4-Pin Spring Clamp Terminal Blocks	440R-A23228

**Approximate Dimensions**

Dimensions are shown in mm (in.). Dimensions are not intended to be used for installation purposes.

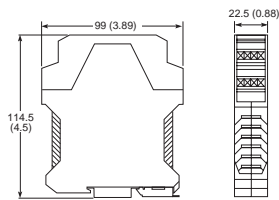

**Block Diagram**

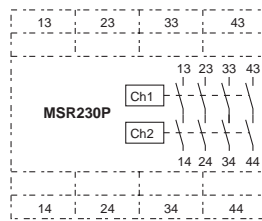

**Typical Wiring Diagrams**

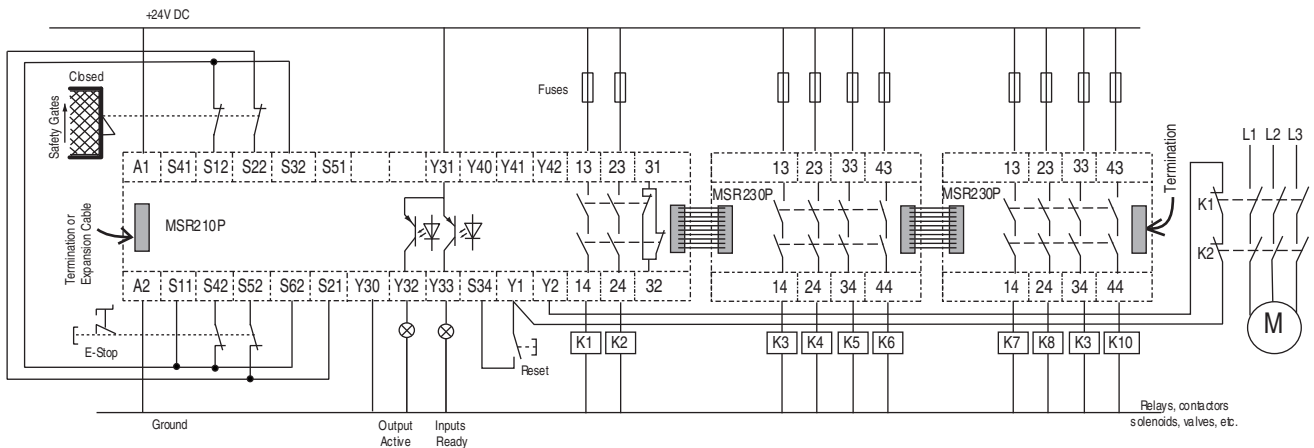

**Dual Channel Safety Gate and E-Stop, Monitored Manual Reset, Monitored Output**

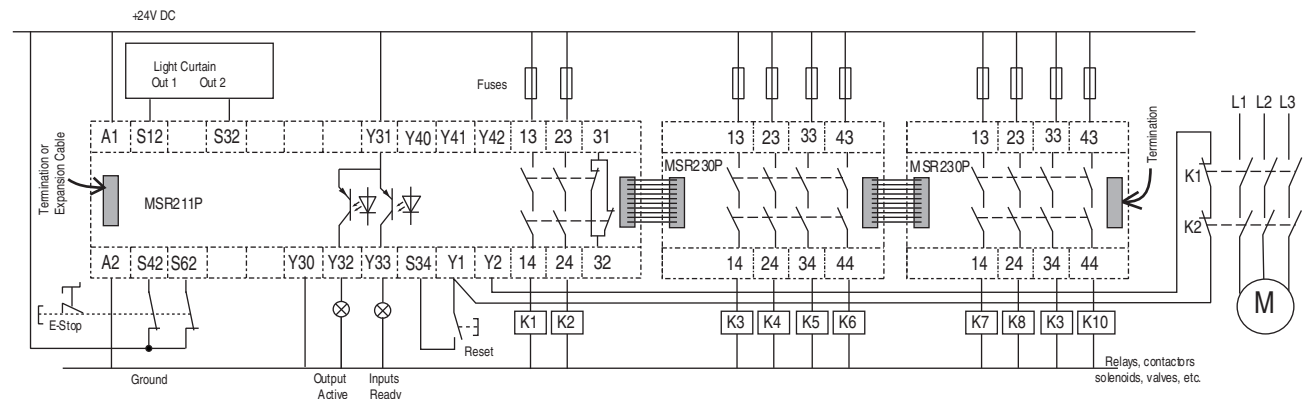

**Light Curtain and Dual Channel E-Stop, Monitored Manual Reset, Monitored Output**

5-Safety Relays



### Description

The MSR238 is an time-delayed output expansion module for the modular Minotaur MSR200 family of monitoring safety relays. It can be connected to either the MSR210 or MSR211 base unit or to the MSR230 output module to provide time-delayed outputs.

Up to two output modules can be connected to one base unit by simply removing the terminator, included with each base unit, and connecting the ribbon cables of the neighboring module. The connecting ribbon cable provides power to the MSR238 as well as a check on its status. The terminators must be inserted into the final output module.

The MSR238 has two safety rated outputs that work in parallel with the safety outputs of the base unit. When the output of the base unit is de-activated, the outputs of the MSR238 are de-activated after the time delay expires. The time delay is set by connecting jumpers to the wiring terminals.

The outputs are two normally open safety rated outputs. The safety outputs have independent and redundant internal contacts to help support the safety function. The delayed normally closed output is an auxiliary signal that must only be used to indicate the status of the MSR238.

### Features

- Category 3 per EN 954-1
- Stop category 1
- Two diagnostic LEDs
- Removable terminals
- Two N.O. delayed safety outputs
- One N.C. delayed auxiliary output

### LED Indicators

Green	CH1 Output Active
Green	CH2 Output Active

### Specifications

Safety Ratings	
Standards	EN 954-1, ISO 13849-1, IEC/EN 60204-1, IEC 60947-4-1, IEC 60947-5-1, ANSI 11.19, AS4024.1
Safety Classification	Cat. 3 per EN 954-1 (ISO 13849-1), SIL CL2 per EN IEC 62061, PLe per ISO 13849-1
Functional Safety Data * <b>Note:</b> For up-to-date information, visit <a href="http://www.ab.com/Safety/">http://www.ab.com/Safety/</a>	PFH <sub>D</sub> : < 7.7 x 10 <sup>-9</sup> MTTF <sub>D</sub> : > 373 years Suitable for performance levels PLe (according to ISO 13849-1:2006) and for use in SIL3 systems (according to IEC 62061) depending on the architecture and application characteristics
Certifications	CE Marked for all applicable directives, cULus, c-Tick, and TÜV
Power Supply	
Input Power Entry	24V DC from the base unit
Power Consumption	2.5 W
Outputs	
Safety Contacts	2 N.O.
Auxiliary Contacts	1 N.C.
Thermal Current/ <i>I<sub>th</sub></i>	1 x 6 A or 2 x 4 A (nonswitching)
Rated Impulse withstand Voltage	2500V
Switching Current @ Voltage, Min.	10 mA @ 10V DC
Fuses, Output	Recommended External 6 A slow blow or 10 A fast acting
Electrical Life (Operations)	220V AC/4 A/880VA cosφ = 0.35...0.1 M 220V AC/1.7 A/375VA cosφ = 0.6...0.5 M 30V DC/2 A/60 W = 1 M 10V DC/0.01 A/0.1 W = 2 M
Mechanical Life	10,000,000 cycles
Utilization Category	
Resistive: AC-1	6 A @ 250V AC
Resistive: DC-1	6 A @ 24V DC
Inductive: AC-15	5 A @ 250V AC
Inductive: DC-13	3 A @ 24V DC
UL:	1 x B300, P300 or 2 x C300, 1 x 6 A or 2 x 4 A Resistive
Environmental and Physical Characteristics	
Enclosure Type Rating/ Terminal Protection	IP40 (NEMA 1)/ IP20
Operating Temperature [C (F)]	-5...+55 ° (23...131 °)
Vibration	10...55 Hz, 0.35 mm
Shock	10 g, 16 ms, 100 shocks
Mounting	35 mm DIN Rail
Weight [g (lbs)]	215 (0.47)
Conductor Size, Max.	0.2...2.5 mm <sup>2</sup> (24...14 AWG)

- \* Usable for ISO 13849-1:2006 and IEC 62061. Data is based on the following assumptions:
- Mission time/Proof test interval of 20 years
  - Functional test at least once within six-month period

**Product Selection**

Delayed Safety Outputs	Delayed Auxiliary Outputs	Terminals	Reset Type	Power Supply	Cat. No.
2 N.O.	1 N.C.	Removable	—	24V DC from the base unit	440R-H23196

**Accessories**

Description	Cat. No.
Bag of 4, 4-Pin Screw Terminal Blocks	440R-A23209
Bag of 4, 4-Pin Spring Clamp Terminal Blocks	440R-A23228

**Approximate Dimensions**

Dimensions are shown in mm (in.). Dimensions are not intended to be used for installation purposes.

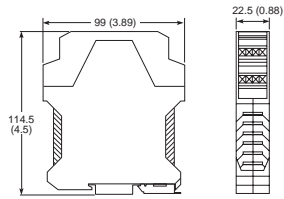

**Block Diagram**

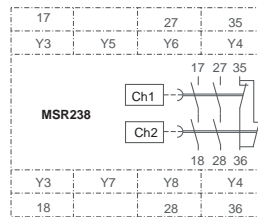

**Typical Wiring Diagrams**

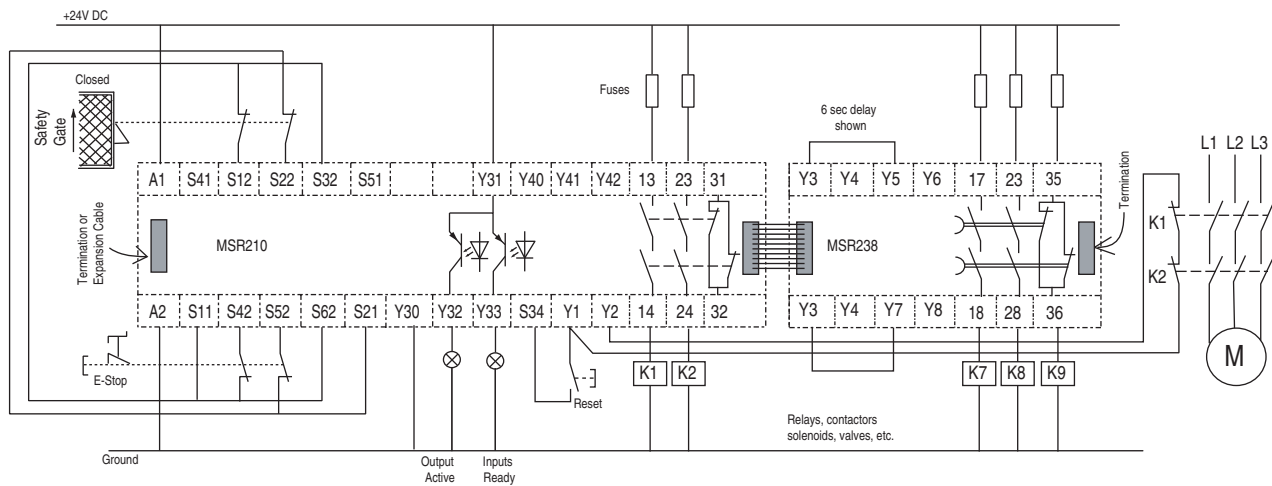

**Application Details (Typical)**

Apply jumpers (links) on the terminals identified to achieve the desired off delay.

Delay (s)	Jumper	Jumper	Delay (s)	Jumper	Jumper	Delay (s)	Jumper	Jumper
0	None	None	8	Y3-Y6	Y3-Y7	50	Y3-Y6	Y3-Y8
0.5	Y3-Y5	None	9	Y4-Y5	Y3-Y7	60	Y4-Y5	Y3-Y8
1	Y4-Y6	None	10	None	Y4-Y8	80	None	Y4-Y7
1.5	Y3-Y6	None	12	Y3-Y5	Y4-Y8	100	Y3-Y5	Y4-Y7
2	Y4-Y5	None	15	Y4-Y6	Y4-Y8	120	Y4-Y6	Y4-Y7
3	Y3-Y5	Y4-Y6	18	Y3-Y6	Y4-Y8	160	Y3-Y6	Y4-Y7
4	Y3-Y6	Y4-Y5	21	Y4-Y5	Y4-Y8	200	Y4-Y5	Y4-Y7
5	None	Y3-Y7	26	None	Y3-Y8	250	Y3-Y5, Y4-Y6	Y3-Y7
6	Y3-Y5	Y3-Y7	30	Y3-Y5	Y3-Y8	300	Y3-Y5, Y4-Y5	Y3-Y7
7	Y4-Y6	Y3-Y7	40	Y4-Y6	Y3-Y8			

## Modular Safety Relays

### MSR240P



#### Description

The MSR240P is a communications module for the modular Minotaur MSR200 family of monitoring safety relays. It can be connected to either the MSR210P or MSR211P base unit to provide diagnostic and status information to remote devices like the MSR245P display.

The MSR240P is connected in place of the terminator plug to the free bus connector of the Basic Module or the last connected Expansion Module, depending on the system configuration. Data transfer and power supply are routed through the same bus cable and connectors.

A green LED in the front of the MSR240P indicates the presence of supply voltage. A blinking yellow LED signals data exchange activity through the RS232/RS485 interface.

The transmission rate for the RS485 can be set with the help of two DIP switch segments at 2400, 4800, 9600, or 19200 baud.

The station address can be set by five additional DIP switch segments. Up to 32 stations can be connected onto a single RS485 network.

The connected supervisory monitoring or data acquisition system can process and store the data, display it, and record the reason causing a shutdown, along with the time and date of each such occurrence. This makes fault diagnosis much easier.

#### Features

- Data transmission
- RS232 or RS485
- Supported baud rates: 2400, 4800, 9600, or 19200
- Galvanically isolated interfaces
- 17.5 mm DIN Rail housing
- Two diagnostic LEDs
- Removable terminals

#### Specifications

Safety Ratings	
Standards	IEC/EN 60204-1, ISOTR 12100
Certifications	CE Marked for all applicable directives
Power Supply	
Input Power Entry	24V DC from the base unit
Power Consumption	2 W
Environmental and Physical Characteristics	
Enclosure Type Rating/ Terminal Protection	IP40 (NEMA 1)/ IP20
Operating Temperature [C (F)]	-5...+55 ° (23...131 °)
Vibration	10...55 Hz, 0.35 mm
Shock	10 g, 16 ms, 100 shocks
Mounting	35 mm DIN Rail
Weight [g (lbs)]	90 (0.20)
Conductor Size, Max.	0.2...4 mm <sup>2</sup> (24...12 AWG)

**Product Selection**

Communication Interface	Cat. No.
RS232	440R-H23181
RS232 + RS485	440R-H23183

**Accessories**

Description	Cat. No.
Bag of 4, 3-Pin Screw Terminal Blocks	440R-A23210
Bag of 4, 3-Pin Spring Clamp Terminal Blocks	440R-A23229

**Approximate Dimensions**

Dimensions are shown in mm (in.). Dimensions are not intended to be used for installation purposes.

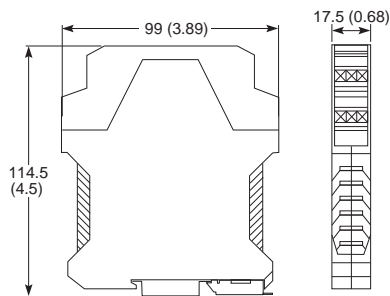

**Block Diagram**

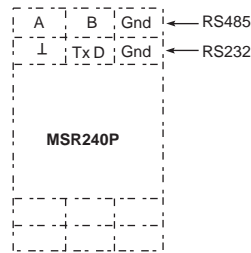

**Typical Wiring Diagrams**

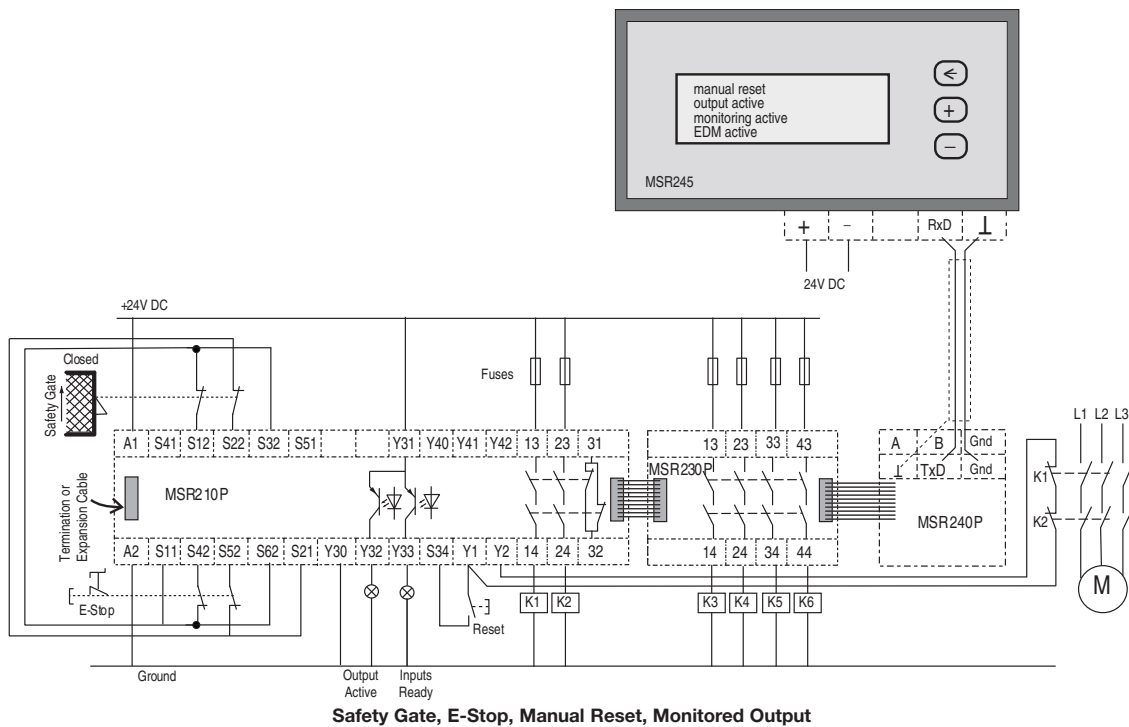

**5-Safety Relays**

# Modular Safety Relays

## MSR241P



### Description

The MSR241P is a DeviceNet™ communications module for the modular Minotaur MSR200 family of monitoring safety relays. It can be connected to either the MSR210P, MSR211P, or MSR230P modules to provide diagnostic and I/O status information to remote locations.

The MSR241P is connected via the flat ribbon cable to the base module or the last connected expansion module, depending on the system configuration. Data transfer and power supply are routed through the same bus cable and connectors.

The MSR241P has two nonsafety rated relay outputs that are activated with the last two bits of the one input byte.

The baud rate and address is set by means of the dipswitch on the front panel.

The connected supervisory monitoring or data acquisition system can process and store the data, display it, and record the reason causing a shutdown, along with the time and date of each such occurrence. This makes fault diagnosis much easier.

### Features

- DeviceNet™ data transmission
- Switch selectable baud rates: 125 K, 250 K, 500 K
- Switch selectable address
- 45 mm DIN Rail housing
- Four diagnostic LEDs
- Removable terminals
- Group two only slave

### LED Indicators

Green	K1 Active
Green	K2 Active
Green	Module Status Operative Network Status
Green	Online
Red	Critical Connection Error
Blinking Green	Connection Interrupted
Blinking Red	Connection Timed Out

### Specifications

Safety Ratings	
Standards	IEC/EN 60204-1, ISOTR 12100, ISO 13849-0
Certifications	CE Marked for all applicable directives
Power Supply	
Input Power Entry	24V DC from the base unit
Power Consumption	2 W
Outputs	
Auxiliary Contacts	2 N.O.
Thermal Current $I_{th}$	2 A @ 30V DC, 300 mA @ 110V DC, 500 mA @ 125V DC
Rated Impulse withstand Voltage	60 W max. switching voltage
Switching Current @ Voltage, Min.	10 mA @ 10V DC
Environmental and Physical Characteristics	
Enclosure Type Rating/ Terminal Protection	IP40 (NEMA 1)/ IP20
Operating Temperature [C (F)]	-5...+50 ° (23...122 °)
Vibration	10...55 Hz, 0.35 mm
Shock	10 g, 16 ms, 100 shocks
Mounting	35 mm DIN Rail
Weight [g (lbs)]	180 (0.396)
Conductor Size, Max.	0.2...2.5 mm (24...12 AWG)

**Product Selection**

Interface Type	Cat. No.
DeviceNet™	440R-H23187

**Approximate Dimensions**

Dimensions are shown in mm (in.). Dimensions are not intended to be used for installation purposes.

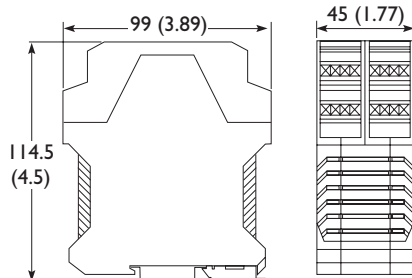

**Block Diagram**

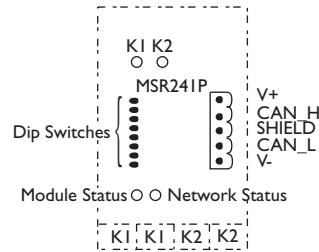

**Typical Wiring Diagrams**

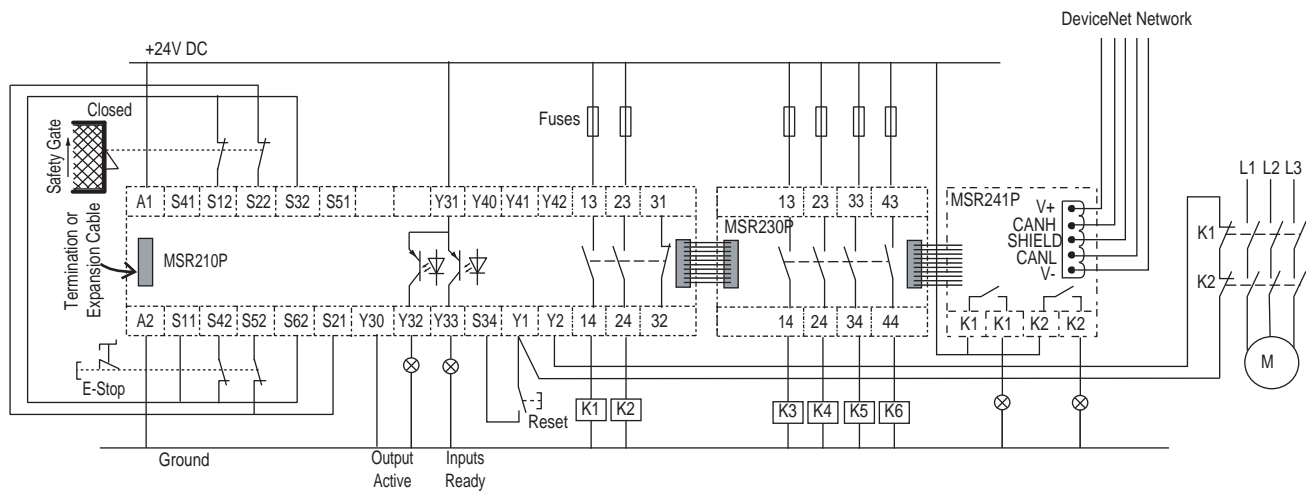

**Switch Settings**

Switch	125K	250K	500K
1	0	0	1
2	0	1	0
3	Bit 5	Switches 3-8 set the node address	
4	Bit 4		
5	Bit 3		
6	Bit 2		
7	Bit 1		
8	Bit 0		



### Description

The MSR245P is a display module for the modular Minotaur MSR200 family of monitoring safety relays. The MSR245P Display Module is interfaced to an MSR200 system through an MSR240P Communication Module, using the RS232 interface, with a two-core shielded cable. The display is refreshed approximately every six seconds.

Using the four-line LCD display and the three function key-switches, the configuration of external circuits, and the on-off status of all inputs of the system can be checked and interrogated.

The microprocessor, in the base module, scans all the inputs starting with the base module and working its way to the left. The first scanned input is "base module input 1." The last scanned input would be input two of the module furthest from the base module.

The display shows the lowest scanned input that de-energized the safety outputs (safety outputs open). After the lowest scanned input is cleared, the display will refresh and show the next input which is open. In this way, each open input circuit can be troubleshot and closed. When all inputs are closed, the user can scroll through the display.

The MSR245P requires 24V DC supply voltage. The power supply input as well as the RS232 are galvanically isolated from the MSR200 system, but can be connected non-isolated if required.

The messages in the MSR245 are capable of being customized with application specific text. The first three lines of the display can be changed to describe each of the inputs (3 x 20 characters). The text language can be selected and written in either English or German.

For programming, a PC running under Windows™ must be connected to the nine-pole sub-miniature D connector on the back of the MSR245 using a standard serial data interface cable.

The program allows the user to generate and transfer the text blocks into the nonvolatile memory of the MSR245.

The software for text programming and the manual is available for download on the Rockwell Automation safety website at [www.ab.com/safety](http://www.ab.com/safety).

### Features

- Recalls and displays system information
- Simple menu selection
- Stores details of last registered stop occurrence
- Clearly readable backlit display
- Back-lit four-line alphanumeric display
- RS232 interface

### Specifications

Safety Ratings	
Standards	IEC/EN 60204-1, ISOTR 12100
Certifications	CE Marked for all applicable directives
Power Supply	
Input Power Entry	24V DC
Power Consumption	0.5 W
Environmental and Physical Characteristics	
Enclosure Type Rating/ Terminal Protection	IP40 (NEMA 1)/ IP20
Operating Temperature [C (F)]	-5...+55 ° (23...131 °)
Vibration	10...55 Hz, 0.35 mm
Shock	10 g, 16 ms, 100 shocks
Mounting	Panel or 35 mm DIN Rail (option)
Weight [g (lbs)]	210 (0.46)
Conductor Size, Max.	0.2...2.5 mm <sup>2</sup> (24...14 AWG)

### Example Messages

**Bold = standard text**

Not Bold = text depending on function

System menu:

Manual/auto **reset**

**Output** active/deactivated

Monitoring active/device ready

**EDM** active/deactivated (feedback circuit)

Input configuration:

Input Module 4

MSR220 emergency off

**Input 1:** 2-channel

**Input 2:** 1-channel

Functions/Interruption messages:

**Input Module 4**

Input 2 causes interrupt

safety mats or cross-fault causes interrupt

transmission fault

fault EDM loop

fault Y40 loop

malfunction

**Output active/inactive**

**Product Selection**

Description	Cat. No.
Display module	440R-H23184
DIN Rail Base Adapter Kit	440R-H23185

**Approximate Dimensions**

Dimensions are shown in mm (in.). Dimensions are not intended to be used for installation purposes.

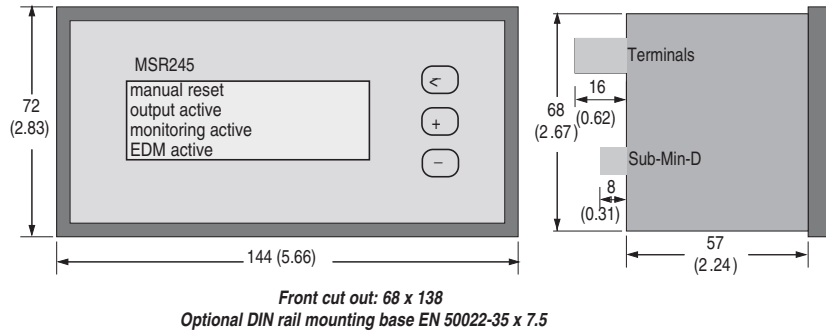

**Typical Wiring Diagrams**

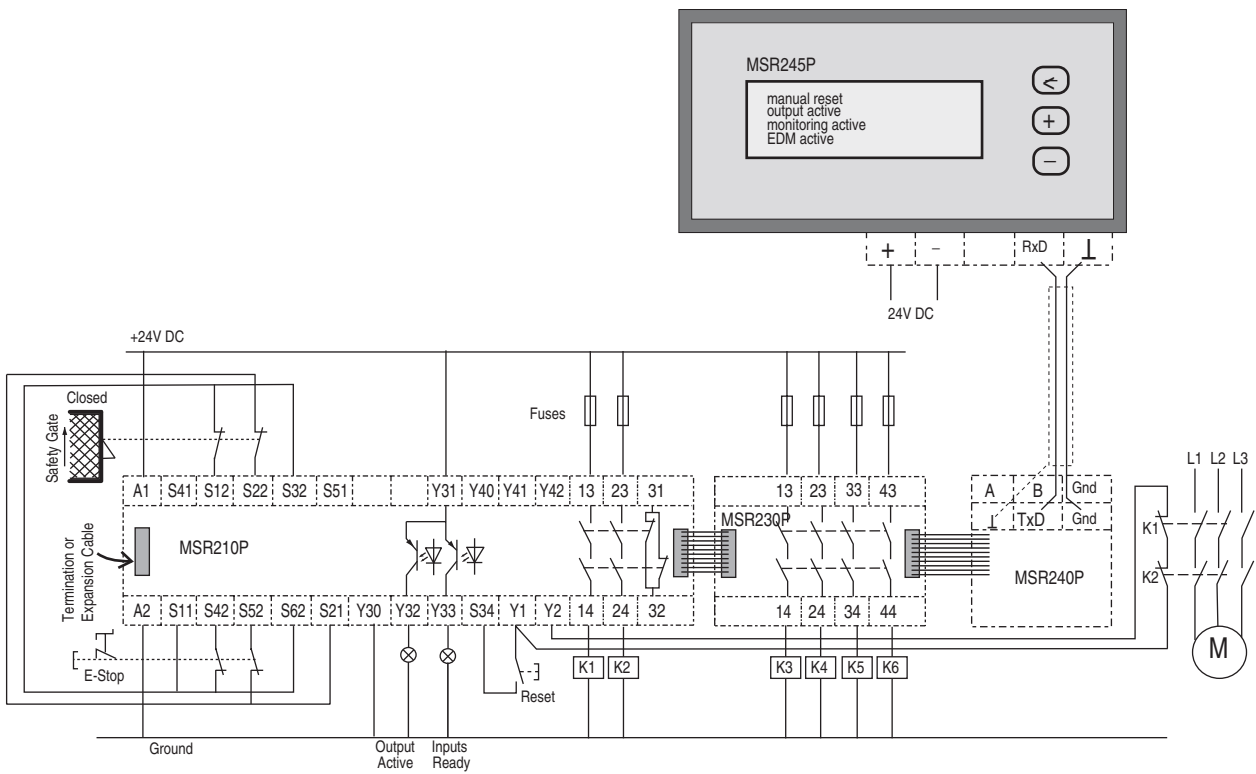

**5-Safety Relays**

Logic  
**Configurable Safety Relays**  
 Module Selection

Input Module Selection

# of inputs	Groups		
	Group 1	Group 2	Group 3
1	MSR320	MSR320	MSR320
2	MSR320	MSR320	MSR320
3	MSR320	MSR320	MSR320
4	MSR320	MSR320	MSR320
5	MSR320	MSR320	MSR320
6	MSR320	MSR320	MSR320
7	MSR320	MSR320	MSR320
8	MSR320	MSR320	MSR320
9	MSR320	MSR320	MSR320
10	MSR320	MSR320	MSR320
11	MSR320	MSR320	MSR320
12	MSR320	MSR320	MSR320
13	MSR320	MSR320	MSR320
14	MSR320	MSR320	MSR320
15	MSR320	MSR320	MSR320
16	MSR320	MSR320	MSR320
17	MSR320	MSR320	MSR320
18	MSR320	MSR320	MSR320
19	MSR320	MSR320	MSR320
20	MSR320	MSR320	MSR320

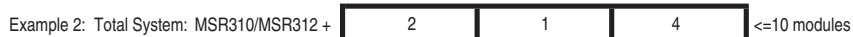

**Note:** If a muting module is required in the application, it counts as one of the ten input modules.

Output Module Selection

Groups # of outputs	Immediate	Immediate	Immediate	Delayed	Delayed	Delayed
	Group 1	Group 2	Group 3	Group 1	Group 2	Group 3
1						
2	W23221	W23222	W23223	W23224	W23225	W23226
3						
4						
5	W23221	W23222	W23223	W23224	W23225	W23226
6						
7						
8	W23221	W23222	W23223	W23224	W23225	W23226
9						
10						
11	W23221	W23222	W23223	W23224	W23225	W23226
12						
13						
14	W23221	W23222	W23223	W23224	W23225	W23226
15						
16						
17	W23221	W23222	W23223	W23224	W23225	W23226
18						

+ + + + + <=6 modules

- Example 1:** 2 Group 1 Immediate Outputs, 1 Group 2 Immediate Outputs, 2 Group 3 Immediate Outputs:
- Example 2:** 1 Group 1 Immediate Outputs, 2 Group 3 Immediate Outputs, 1 Group 1 Delayed Outputs:
- Example 3:** 1 Group 2 Immediate Outputs, 2 Group 3 Immediate Outputs, 3 Group 3 Delayed Outputs:

2	1	2	0	0	0
1	0	2	1	0	0
0	1	2	0	0	3

5

4

6

Total Modules

# Configurable Safety Relays

MSR310P RS232



## Description

The MSR310P is one of the base units available for the MSR300 system. It can be combined with other modules of the MSR300 Series to configure a safety control system with numbers of inputs and outputs matching users' specific application requirements, as well as diagnostic and networking capabilities. Up to ten input modules and six output modules can be connected to one base unit by simply removing the terminator, included with each base unit, and connecting the ribbon cables of the neighboring module. The terminators must be inserted into the final input and output modules. A fully utilized system can support up to 20 inputs devices (e-stops/gates) and 18 normally open outputs.

The MSR300 System supports up to three group outputs. The input modules can be configured to control one or more of the output groups. This creates flexibility for the customer to solve applications requiring simple logic functions (simple AND and OR function). No software is needed for configuration, only rotary switches on the Input Modules are required. Please see the Input Modules for more information.

The base module supports multiple reset configurations for each group output. The user can select from the following choices: manual, manual monitored and automatic reset. The reset configuration is set up by jumpers on the base module terminals. If manual monitored and automatic reset is mixed, the preferred combination of Output Group Modules should be considered.

The MSR310P base module does not have any inputs or safety outputs within the device. A minimum of one input module and one output module are required to make a functional system. The base module does have three solid-state auxiliary outputs to signify the status of the output groups—one output for each Group (1, 2, or 3).

The MSR310P has the capability to monitor external devices individually for each group with a separate feedback loop control.

## Features

- Category 4 per EN 954-1
- SIL3 per IEC 61508
- EN 574 Type IIIC
- Stop category 0
- Pulsed input monitoring
- Three auxiliary group outputs
- Six diagnostic LEDs
- Manual, monitored or automatic reset
- Zone control—up to three
- RS232 Diagnostic Comms
- Unidirectional RS232, 4800 baud
- Bidirectional RS232, 2400, 4800, 9600, 19200 baud
- Removable terminals

## Specifications

Safety Ratings	
Standards	IEC/EN 60204-1, ISOTR 12100, EN 61508, ISO 13849-1
Safety Classification	Cat. 4 per EN 954-1 (ISO 13849-1), SIL CL3 per EN IEC 62061, PLe per ISO 13849-1
Functional Safety Data *	PFH <sub>D</sub> : < 3.15 x 10 <sup>-9</sup> MTTFD: > 396 years <b>Note:</b> For up-to-date information, visit <a href="http://www.ab.com/Safety/">http://www.ab.com/Safety/</a> Suitable for performance levels Pl <sub>e</sub> (according to ISO 13849-1:2006) and for use in SIL3 systems (according to IEC 62061) depending on the architecture and application characteristics
Certifications	CE Marked for all applicable directives, cULus, C-Tick, and TÜV
Power Supply	
Input Power Entry	24V DC 0.8...1.1 x rated voltage PELV/SELV
Power Consumption	5 W
Inputs	
Safety Inputs	MSR300 Series Input Modules
Input Simultaneity	Infinite or 3 seconds
Reset	Auto./Manual or Monitored Manual
Power On Delay/Recovery Time	3 seconds/26 ms + 6 ms per connected input
Response Time	26 ms + 6 ms per connected input
Outputs	
Auxiliary Contacts	3 PNP, 24V DC @ 50 mA
Environmental and Physical Characteristics	
Enclosure Type Rating/Terminal Protection	IP40 (NEMA 1)/IP20, DIN 0470
Operating Temperature [C (F)]	-5...+55 ° (23...131 °)
Vibration	10...55 Hz, 0.35 mm
Shock	10 g, 16 ms, 100 shocks
Mounting	35 mm DIN Rail
Weight [g (lbs)]	210 (0.46)
Conductor Size, Max.	0.2...2.5 mm <sup>2</sup> (#24...12 AWG)

\* Usable for ISO 13849-1:2006 and IEC 62061. Data is based on the following assumptions:  
 - Mission time/Proof test interval of 20 years  
 - Functional test at least once within six-month period

## System-Supported Inputs

- 1 N.C., 2 N.C., or 3 N.C. inputs—E-stops/Gates
- 1 N.C. and 1 N.O. inputs—Gates
- Two-Hand Control
- Two OSSD—Light Curtains
- Safety Mats

**Product Selection**

Safety Inputs	Safety Outputs	Auxiliary Outputs	Terminals	Reset Type	Power Supply	Cat. No.
MSR300 Series Input Modules	MSR300 Series Output Modules	3 PNP Solid State	Removable	Auto./Manual Monitored Manual	24V DC	440R-W23219

**Accessories**

Description	Cat. No.
MSR300 Two Terminators	440R-A17234
Bag of 4, 3-Pin Screw Terminal Blocks	440R-A23210
Bag of 4, 3-Pin Spring Clamp Terminal Blocks	440R-A23229

**Approximate Dimensions**

Dimensions are shown in mm (in.). Dimensions are not intended to be used for installation purposes.

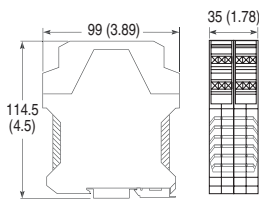

**Block Diagram**

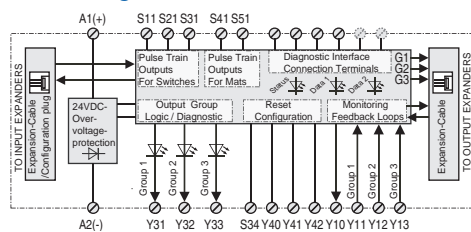

**Typical Wiring Diagrams**

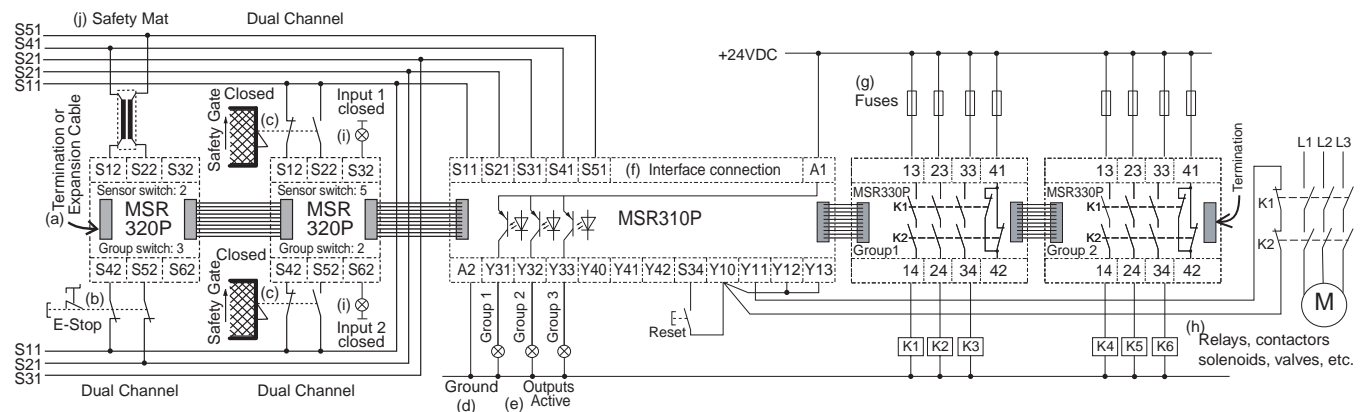

(k) MSR 300 system with various Inputs, Two Output Groups with common monitored reset, Group 1 with monitored contactors  
 Safety Mat or E-Stop shut down both Output modules, Safety Gates only shut down the Group 2 module

**Reset Behavior**

Reset Behavior	Circuit
Groups 1 and 2: manual, monitored reset Group3: automatic reset	
Groups 1 and 2: automatic reset Group3: manual, monitored reset	
Groups 1, 2, and 3: manual, monitored reset	
Groups 1, 2, and 3: automatic reset	

## Configurable Safety Relays

MSR312P DeviceNet™



### Description

The MSR312P is one of the base units available for the MSR300 system. It can be combined with other modules of the MSR300 Series to configure a safety control system with numbers of inputs and outputs matching users' specific application requirements, as well as diagnostic and networking capabilities. Up to ten input modules and six output modules can be connected to one base unit by simply removing the terminator, included with each base unit, and connecting the ribbon cables of the neighboring module. The terminators must be inserted into the final input and output modules. A fully utilized system can support up to 20 inputs devices (e-stops/gates) and 18 normally open outputs.

The MSR300 System supports up to three group outputs. The input modules can be configured to control one or more of the output groups. This creates flexibility for the customer to solve applications requiring simple logic functions (simple AND and OR function). No software is needed for configuration, only rotary switches on the Input Modules are required. Please see the Input Modules for more information.

The base module supports multiple reset configurations for each group output. The user can select from the following choices: manual, manual monitored and automatic reset. The reset configuration is set up by jumpers on the base module terminals. If manual monitored and automatic reset is mixed, the preferred combination of Output Group Modules should be considered.

The MSR312P base module does not have any inputs or safety outputs within the device. A minimum of one input module and one output module are required to make a functional system. The base module does have three solid-state auxiliary outputs to signify the status of the output groups—one output for each group (1, 2, or 3).

The MSR312P has the capability to monitor external devices individually for each group with a separate feedback loop control.

### Features

- Category 4 per EN 954-1
- SIL3 per IEC 61508
- EN 574 Type IIIC
- Stop category 0
- Pulsed input monitoring
- Three auxiliary group outputs
- One PNP solid state output controlled via DeviceNet™ connection
- Six diagnostic LEDs
- Manual, monitored or automatic reset
- Zone control—up to three
- DeviceNet™ Comms including UCMM
- Support baud rates: 125 k, 250 k, 500 k
- Removable terminals

### Specifications

Safety Ratings	
Standards	IEC/EN 60204-1, ISOTR 12100, EN 61508, ISO 13849-1
Safety Classification	Cat. 4 per EN 954-1 (ISO 13849-1), SIL CL3 per EN IEC 62061, PLe per ISO 13849-1
Functional Safety Data *	PFH <sub>D</sub> : < 3.15 x 10 <sup>-9</sup> MTTF <sub>D</sub> : > 396 years <b>Note:</b> For up-to-date information, visit <a href="http://www.ab.com/Safety/">http://www.ab.com/Safety/</a>
Certifications	CE Marked for all applicable directives, cULus, c-Tick, and TÜV
Power Supply	
Input Power Entry	24V DC 0.8...1.1 x rated voltage PELV/SELV
Power Consumption	3 W
Inputs	
Safety Inputs	MSR300 Series Input Modules
Input Simultaneity	Infinite or 3 seconds
Reset	Auto./Manual or Monitored Manual
Power On Delay/Recovery Time	3 seconds/26 ms + 6 ms per connected input
Response Time	26 ms + 6 ms per connected input
Outputs	
Auxiliary Contacts	3 PNP, Diagnostic, 1 PNP Output, 24V DC @ 50 mA
Switching Current @ Voltage, Min.	24V DC @ 50 mA
Environmental and Physical Characteristics	
Enclosure Type Rating/Terminal Protection	IP40 (NEMA 1)/IP20, DIN 0470
Operating Temperature [C (F)]	-5...+55 ° (23...131 °)
Vibration	10...55 Hz, 0.35 mm
Shock	10 g, 16 ms, 100 shocks
Mounting	35 mm DIN Rail
Weight [g (lbs)]	210 (0.46)
Conductor Size, Max.	0.2...2.5 mm <sup>2</sup> (24... AWG)

- \* Usable for ISO 13849-1:2006 and IEC 62061. Data is based on the following assumptions:
- Mission time/Proof test interval of 20 years
  - Functional test at least once within six-month period

### System-Supported Inputs

- 1 N.C., 2 N.C., or 3 N.C. inputs—E-stops/Gates
- 1 N.C. and 1 N.O inputs—Gates
- Two-Hand Control
- Two OSSD—Light Curtains
- Safety Mats

**Product Selection**

Safety Inputs	Safety Outputs	Auxiliary Outputs	Terminals	Reset Type	Power Supply	Cat. No.
MSR300 Series Input Modules	MSR300 Series Output Modules	3 PNP, DeviceNet	Removable	Auto./Manual or Monitored Manual	24V DC	440R-W23220

**Accessories**

Description	Cat. No.
MSR300 Two Terminators	440R-A17234
Bag of 4, 3-Pin Screw Terminal Blocks	440R-A23210
Bag of 4, 3-Pin Spring Clamp Terminal Blocks	440R-A23229

**Approximate Dimensions**

Dimensions are shown in mm (in.). Dimensions are not intended to be used for installation purposes.

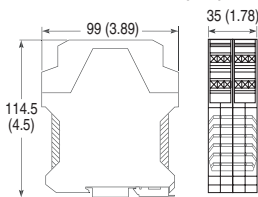

**Block Diagram**

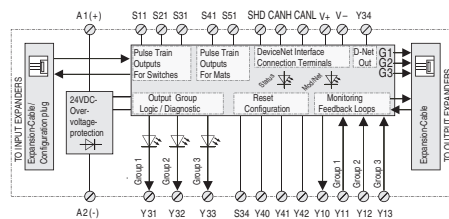

**Typical Wiring Diagrams**

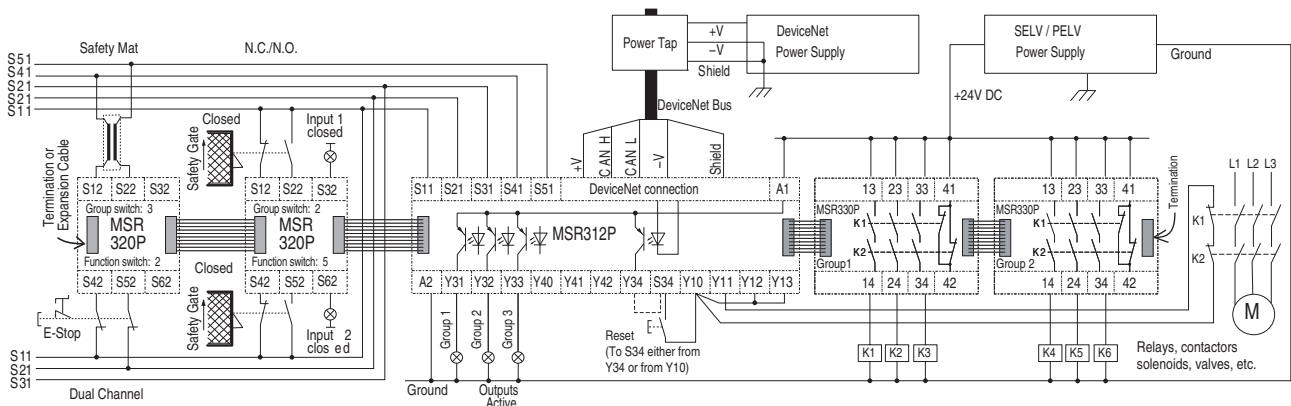

MSR300 system with various Inputs, Two Output Groups with common monitored reset (reset alternative via DeviceNet with S34 linked to Y34), Group 1 with monitored contactors Safety Mat or E-Stop shut down both Output modules, Safety Gates only shut down the Group 2 module.

**Reset Behavior**

Reset Behavior	Circuit
Groups 1 and 2: manual, monitored reset Group3: automatic reset	
Groups 1 and 2: automatic reset Group3: manual, monitored reset	
Groups 1, 2, and 3: manual, monitored reset	
Groups 1, 2, and 3: automatic reset	

# Configurable Safety Relays

## MSR320P Input Module



### Description

The MSR320P is an input expansion module for the modular MSR300 family of monitoring safety relays. Up to ten input modules can be connected to a base unit by simply removing the terminator, included with each base unit, and connecting the ribbon cables of the neighboring module. The connecting ribbon cable provides power to the MSR320P as well as a check on its status. The terminator removed from the base module must be inserted into the input module furthest to the left.

Although the base module of the MSR300 system holds all of the configuration information, the input modules are the devices that actually configure the base module. The input modules select both the type of inputs connected and the outputs or groups those inputs will control.

The MSR320P has two independent inputs, which are configured by the rotary switches on the side of the module. There are two switches, for redundancy, so both must be set to the same value. An example of the switch settings is to the right. The selection of the switch setting signifies to the base module what inputs to expect and what to test for. Connecting a single device (must be at least dual channel) to each input meets the requirements of Category 4 per EN594-1. Below is a list of supported inputs.

The MSR320P Input module supports up to three group outputs. Two rotary switches, for redundancy, on the side of the module select the output group or groups the connected inputs will control. Below is an example of the possible group settings.

When three channel N.C. inputs are not chosen, functions switch setting three, one solid-state output is available for each input to provide annunciation for that input.

Two LEDs provide the status information on the inputs. Green indicates the input is closed and red indicates the input is open. Three LEDs provide information regarding which output groups are controlled by this input module.

### Features

- Category 4 per EN 954-1
- SIL3 IEC 61508
- EN 574 Type IIIC
- Stop category 0
- 17.5 mm DIN Rail housing
- Five diagnostic LEDs
- Configurable inputs
- Output group configurable
- Removable terminals

### LED Indicators

2x input status	Input Closed
Green	Input Open; 3x output switch group assignment

### Specifications

Safety Ratings	
Standards	IEC/EN 60204-1, ISO TR 12100, EN 61508, ISO 13849-1, EN 574 Cat IIIC
Safety Classification	Cat. 4 per EN 954-1 (ISO 13849-1), SIL CL3 per EN IEC 62061, PLe per ISO 13849-1
Functional Safety Data * <b>Note:</b> For up-to-date information, visit <a href="http://www.ab.com/Safety/">http://www.ab.com/Safety/</a>	PFH <sub>D</sub> : < 3.1 x 10 <sup>-10</sup> MTTF <sub>d</sub> : > 835 years Suitable for performance levels Pl <sub>e</sub> (according to ISO 13849-1:2006) and for use in SIL3 systems (according to IEC 62061) depending on the architecture and application characteristics
Certifications	CE Marked for all applicable directives, cULus, c-Tick, and TÜV
Power Supply	
Input Power Entry	24V DC from the base unit
Power Consumption	3 W
Inputs	
Safety Inputs	1 N.C., 2 N.C., or 3 N.C., 1 N.C and 1 N.O., LC, SM, or two-hand control
Input Simultaneity	3 seconds or infinite
Input Resistance, Max.	900 Ω
Reset	Selected on base module
Outputs	
Auxiliary Contacts	2 PNP, 24V DC @ 50 mA
Environmental and Physical Characteristics	
Enclosure Type Rating/ Terminal Protection	IP40 (NEMA 1)/ IP20, DIN 0470
Operating Temperature [C (F)]	-5...+55 ° (23...131 °)
Vibration	10...55 Hz, 0.35 mm
Shock	10 g, 16 ms, 100 shocks
Mounting	17.5 mm housing, 35 mm DIN Rail
Weight [g (lbs)]	110 (0.24)
Conductor Size, Max.	0.2...2.5 mm <sup>2</sup> (24...12 AWG)

\* Usable for ISO 13849-1:2006 and IEC 62061. Data is based on the following assumptions:  
 - Mission time/Proof test interval of 20 years  
 - Functional test at least once within six-month period

### System-Supported Inputs

- E-stops
- Safety Gates
- Safety Mats
- Light Curtains
- Two-Hand Control

### Input Configurations

- 1 N.C., 2 N.C., 3 N.C.
- 1 N.C. and 1 N.O.
- 2 OSSD
- 3-second or infinite simultaneity

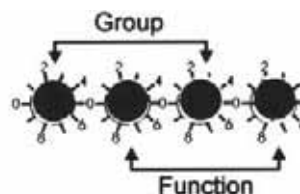

Group	
0: Logic function	5: Group 1+3
1: Group 1	6: Group 2+3
2: Group 2	7: Group 1+2+3
3: Group 1+2	8: Muting - Robotcell
4: Group 3	9: Add Safe Area
Function	
1: 1-channel 1N/C	
2: 2-channel 2N/C, Safety Mat	
3: 3-channel 3N/C	
4: Safety gate with startup-test 1N/C 1N/O	
5: Safety gate 1N/C 1N/O	
6: Light curtain 2OSSD	
7: Two-hand control 2 sets of 1N/C+1N/O	
8: Input1: 2-channel Input2: Light curtain	
9: Input1: Safety gate Input2: Light curtain	

**Product Selection**

Safety Inputs	Safety Outputs	Auxiliary Outputs	Terminals	Reset Type	Power Supply	Cat. No.
1 N.C., 2 N.C., or 3 N.C., 1 N.C and 1 N.O., LC, SM, or two-hand control	—	2 PNP Solid State	Removable	—	24V DC from the base unit	440R-W23218

**Accessories**

Description	Cat. No.
Bag of 4, 3-Pin Screw Terminal Blocks	440R-A23210
Bag of 4, 3-Pin Spring Clamp Terminal Blocks	440R-A23229

**Approximate Dimensions**

Dimensions are shown in mm (in.). Dimensions are not intended to be used for installation purposes.

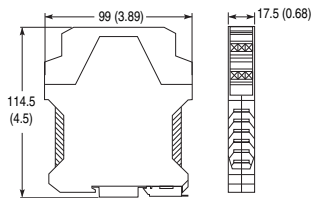

**Block Diagram**

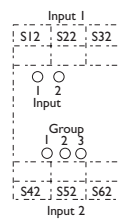

**Typical Wiring Diagrams**

**Wiring of input according to switch-selected function**

Applications in the first row have infinite time to reset the contacts per input. Second row options require the connection per input to be simultaneous reset (within three second time frame). \*

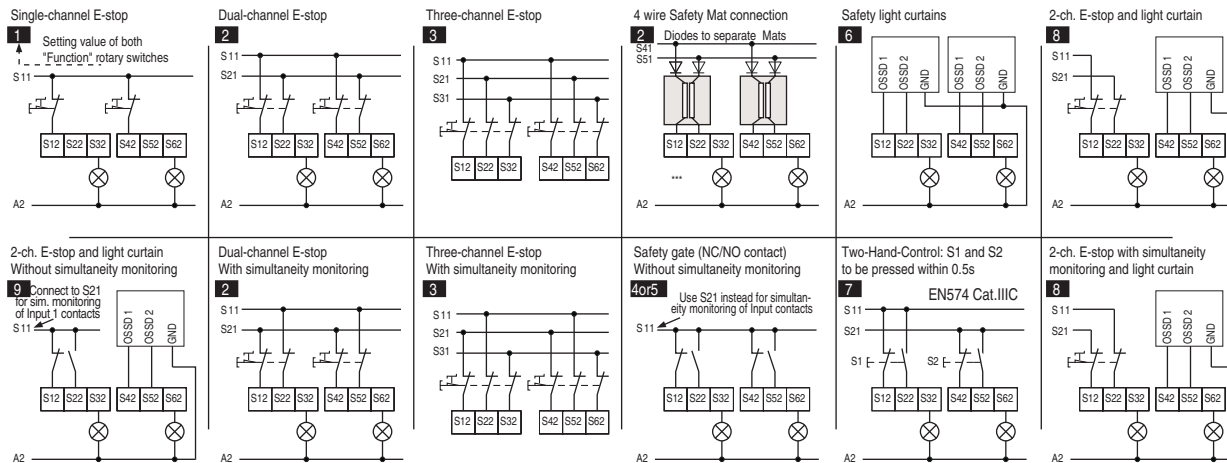

\* "Infinite Reset" and "Simultaneous Reset" time refers to the amount of time the user has to close all the contacts of one input without causing a fault condition. Infinite configuration indicates to the base unit NOT to check when the contacts close. Simultaneous reset time requires that all the contacts on each input MUST reset within 3 seconds or a fault/lockout condition will occur.  
 \* When applying safety mats to the MSR300, it is recommended to use diodes, as shown, to indicate which mat has been pressed. If only one safety mat is connected to the system, no diodes are needed.

## Configurable Safety Relays

### MSR329 Muting Lamp Module



#### Description

The MSR329P is an input expansion module for the modular MSR300 family to monitor the function of connected muting lamps if the system is setup for a robot cell application. One muting lamp module can be used in each MSR300 system. To use the muting module there must be at least two MSR320P input modules. The muting lamp module can be connected anywhere in the string of input modules but the terminator must be located in the left most module. The connecting ribbon cable provides power to the MSR329P as well as a check on its status. The muting lamp module is used to drive and to monitor the muting lamps only. The MSR320 input module can operate a muted cell operation without the muting lamp module present.

The MSR329P can be used for robot cell applications when the application requires a portion(s) of the inputs devices to the cell to be temporarily disabled. If for example, parts needed to be added or removed from the machine. The light curtain may need to be muted during this time to prevent the machine from stopping during this condition. Interlock switches can be used to determine the position of the robot within the cell to initiate the muting function.

When using the muting module, group three MSR330P output modules are required for the robot control or power. Group outputs 1 and 2 will still change state normally when an input changes state such as a light curtain. Output groups 1 and 2 are not required for robot cell applications but can be used to remove hazardous local voltages such as an arc welder during a muting condition.

The muting module has two main lamp modules and two spare lamp modules. If the main lamp module fails, the spare lamp module will be used. The MSR329P muting module requires an incandescent bulb operating between 30...200 mA to accurately determine the bulb status. LEDs cannot be used. Two LEDs provide the status information on all four lamps. They indicate if the bulbs are okay or if any have failed.

#### Lamp Outputs

- Two Main Lamps
- Two Auxiliary Lamps

#### Features

- Category 4 per EN 954-1
- SIL3 IEC 61508
- 17.5 mm DIN Rail housing
- Two Diagnostic LEDs
- Removable terminals

#### Specifications

Safety Ratings	
Standards	IEC/EN 60204-1, ISO TR 12100, EN 61508, ISO 13849-1 (EN 954-1)
Safety Classification	Cat. 4 per EN 954-1 (ISO 13849-1), SIL CL3 per EN IEC 62061, PLe per ISO 13849-1
Functional Safety Data *	PFH <sub>D</sub> : < 3.8 x 10 <sup>-10</sup> MTTFd: > 662 years <b>Note:</b> For up-to-date information, visit <a href="http://www.ab.com/Safety/">http://www.ab.com/Safety/</a> Suitable for performance levels Pl <sub>e</sub> (according to ISO 13849-1:2006) and for use in SIL3 systems (according to IEC 62061) depending on the architecture and application characteristics
Certifications	CE Marked for all applicable directives, cULus, c-Tick, and TÜV
Power Supply	
Input Power Entry	24V DC from the base unit
Power Consumption	1 W
Inputs	
Safety Inputs	Monitoring of 2 muting lamps 24V DC current between 30...200 mA
Reset	Selected on base module
Outputs	
Safety Contacts	2 x muting lamps, 2 x reserve lamps
Status Indicator	Status of lamps
Environmental and Physical Characteristics	
Enclosure Type Rating/ Terminal Protection	IP40 (NEMA 1)/ IP20, DIN 0470
Operating Temperature [C (F)]	-5...+55 ° (23...131 °)
Vibration	10...55 Hz, 0.35 mm
Shock	10 g, 16 ms, 100 shocks
Mounting	35 mm DIN Rail
Weight [g (lbs)]	110 (0.24)
Conductor Size, Max.	0.2...2.5 mm <sup>2</sup> (24...12 AWG)

\* Usable for ISO 13849-1:2006 and IEC 62061. Data is based on the following assumptions:

- Mission time/Proof test interval of 20 years
- Functional test at least once within six-month period

**Product Selection**

No. of Main Lamps	No. of Auxiliary Lamps	Current Range	Terminals	Reset Type	Power Supply	Cat. No.
2	2	30...200 mA	Removable	—	24V DC from the base unit	440R-W23217

**Accessories**

Description	Cat. No.
Bag of 4, 3-Pin Screw Terminal Blocks	440R-A23210
Bag of 4, 3-Pin Spring Clamp Terminal Blocks	440R-A23229

**Approximate Dimensions**

Dimensions are shown in mm (in.). Dimensions are not intended to be used for installation purposes.

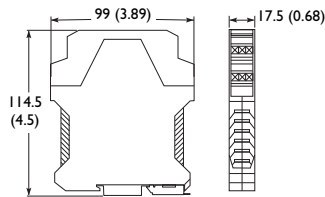

**Block Diagram**

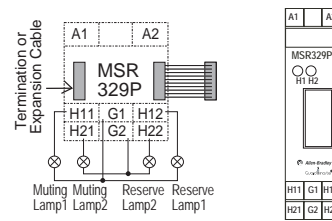

**Typical Wiring Diagrams**

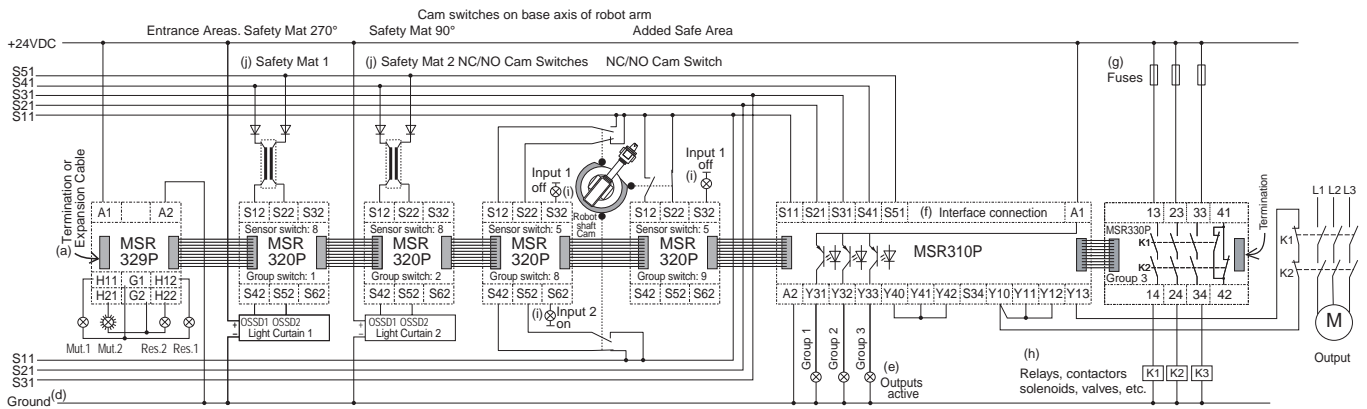

MSR300 three-zone Robot Cell application allowing safe material flow in and out of the cell without process interruption as long as the robot arm is working in monitored safe zones.

# Configurable Safety Relays

## MSR330P Output Module



### Description

The MSR330P is an output expansion module for the modular Minotaur MSR300 family of monitoring safety relays. Up to six MSR330P output modules and 18 N.O. safety outputs, can be connected to one base unit by simply removing the terminator, included with each base unit, and connecting the ribbon cables of the neighboring module. The six MSR330P output modules can be used in any combination and order when connected to the MSR300 system. The connecting ribbon cable provides power to the MSR330P as well as a check on its status. The terminator must be inserted into the final output module.

The MSR330P has three safety-rated outputs and one auxiliary output controlled by the base unit. There are three different MSR330P modules, one for each group. In most instances, the output group module is not specific to each application. The exceptions are robot cell applications and logic or functions which correspond with group three outputs. The safety outputs have independent and redundant internal contacts to help support the safety function.

### Features

- Category 4 per EN 954-1
- SIL3 IEC 61508
- Stop category 0
- Three N.O. safety outputs
- One N.C. auxiliary output
- Three group modules available
- Two Diagnostic LEDs
- 22.5 mm DIN Rail housing
- Removable terminals

### Specifications

Safety Ratings	
Standards	IEC/EN 60204-1, ISO TR 12100, EN 61508, ISO 13849-1 (EN 954-1)
Safety Classification	Cat. 4 per EN 954-1 (ISO 13849-1), SIL CL3 per EN IEC 62061, PLe per ISO 13849-1
Functional Safety Data *	PFH <sub>D</sub> : < 2.3 x 10 <sup>-10</sup> MTTF <sub>D</sub> : > 454 years Suitable for performance levels Pl <sub>e</sub> (according to ISO 13849-1:2006) and for use in SIL3 systems (according to IEC 62061) depending on the architecture and application characteristics
Certifications	CE Marked for all applicable directives, cULus, c-Tick, and TÜV
Power Supply	
Input Power Entry	24V DC from the base unit
Power Consumption	1.5 W
Inputs	
Reset	Selected on base module
Response Time	Does not add additional response time to base module
Outputs	
Safety Contacts	3 N.O.
Auxiliary Contacts	1 N.C.
Thermal Current <sub>1th</sub>	2 x 6 A or 3 x 5 A
Rated Impulse withstand Voltage	2500V
Switching Current @ Voltage, Min.	10 mA @ 10V
Fuses, Output	External 6 A slow blow or 10 A quick blow
Mechanical Life	2,000,000 cycles
Utilization Category	
UL	B300, P300, 2 x 6 A or 3 x 5 A/250V AC, 24V DC
Environmental and Physical Characteristics	
Enclosure Type Rating/ Terminal Protection	IP40 (NEMA 1)/ IP20, DIN 0470
Operating Temperature [C (F)]	-5...+55 ° (23...131 °)
Vibration	10...55 Hz, 0.35 mm
Shock	10 g, 16 ms, 100 shocks
Mounting	35 mm DIN Rail
Weight [g (lbs)]	190 (0.42)
Conductor Size, Max.	0.2...2.5 mm <sup>2</sup> (24...12 AWG)

\* Usable for ISO 13849-1:2006 and IEC 62061. Data is based on the following assumptions:  
 - Mission time/Proof test interval of 20 years  
 - Functional test at least once within six-month period

**Product Selection**

Group No.	Safety Outputs	Auxiliary Outputs	Terminals	Reset Type	Power Supply	Cat. No.
1	3 N.O.	1 N.C.	Removable	Selected on base module	24V DC	440R-W23221
2						440R-W23222
3						440R-W23223

**Accessories**

Description	Cat. No.
Bag of 4, 4-Pin Screw Terminal Blocks	440R-A23209
Bag of 4, 4-Pin Spring Clamp Terminal Blocks	440R-A23228

**Approximate Dimensions**

Dimensions are shown in mm (in.). Dimensions are not intended to be used for installation purposes.

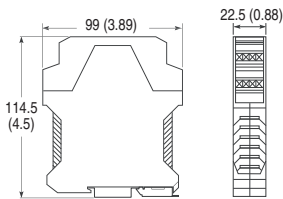

**Block Diagram**

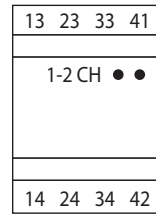

**Typical Wiring Diagrams**

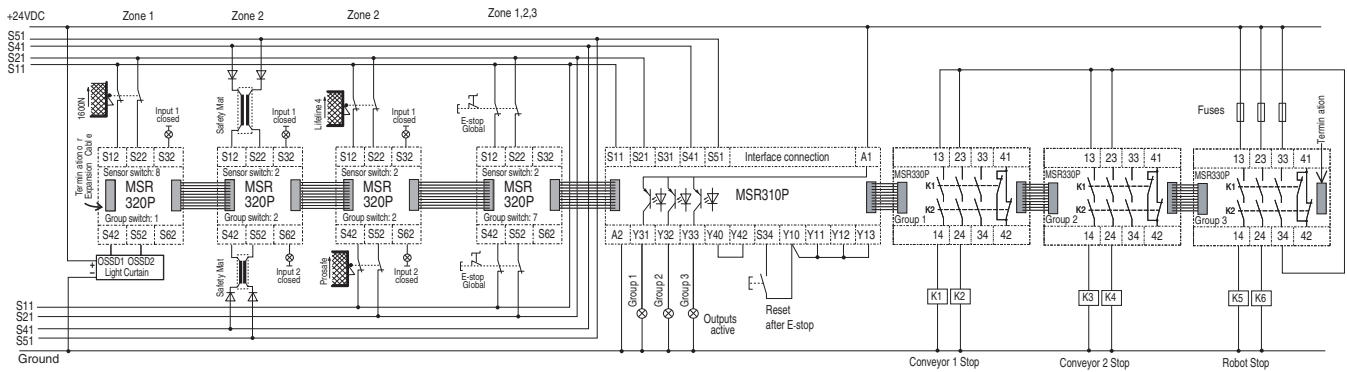

Zone 1 inputs shut down conveyor 1 and zone 2 inputs shut down conveyor 2, global e-stops shut down the complete line and require a reset.

# Configurable Safety Relays

## MSR338DP



### Description

The MSR338 is an time-delayed output expansion module for the configurable Minotaur MSR300 family of monitoring safety relays. Up to six output modules, can be connected to one base unit by simply removing the terminator, included with each base unit, and connecting the ribbon cables of the neighboring module. The MSR338DP output modules can be used in any combination and order also together with the instant modules MSR330P when connected to the MSR300 system. The connecting ribbon cable provides power to the MSR338DP as well as a check on its status. The terminator must be inserted into the final output module.

There are three different MSR338P modules, one for each group. In most instances, the output group module is not specific to each application. The exceptions are robot cell applications and logic OR functions which correspond with group three outputs.

The MSR338 has three safety rated outputs that work in parallel with the immediate safety outputs of the MSR330P outputs modules. When the output signal from the base unit is de-activated, the outputs of the MSR338 are de-activated after the time delay expires. The time delay is set by connecting jumpers to the wiring terminals. The outputs are three normally open and one normally closed safety rated outputs. The safety outputs have independent and redundant internal contacts to help support the safety function.

### Features

- Category 3 per EN 954-1 performance
- Level D per ISO 13849-1 Stop category 1
- Three N.O. safety outputs
- One N.C. safety output
- Three group modules available
- Diagnostic LED
- 22.5 mm DIN Rail housing
- Removable terminals

### LED Indicators

Off	Output Inactive
Green	Output Active

### Specifications

Safety Ratings	
Standards	EN 954-1, EN IEC 62061, ISO 13849-1, IEC/EN 60204-1, ISO 12100, IEC 60947-4-1, IEC 60947-5-1, ANSI B11.19, AS 4024.1
Safety Classification	Cat. 3 per EN 954-1 (ISO 13849-1), SIL CL2 per EN IEC 62061, PLe per ISO 13849-1
Functional Safety Data * <b>Note:</b> For up-to-date information, visit <a href="http://www.ab.com/Safety/">http://www.ab.com/Safety/</a>	PFH <sub>D</sub> : < 7.7 x 10 <sup>-10</sup> MTTF <sub>d</sub> : > 373 years Suitable for performance levels Ple (according to ISO 13849-1:2006) and for use in SIL3 systems (according to IEC 62061) depending on the architecture and application characteristics
Certifications	CE Marked for all applicable directives, cULus, c-Tick, and TÜV

Power Supply	
Input Power Entry	24V DC from base unit
Power Consumption	2.5 W

Inputs	
Safety Inputs	Configured on base unit
Reset	Configured on base unit

Outputs	
Safety Contacts	3 N.O.
Auxiliary Contacts	1 N.C.
Thermal Current <sub>1/1h</sub>	2 x 5 A, 3 x 4 A (nonswitching)
Rated Impulse withstand Voltage	2500V
Switching Current @ Voltage, Min.	10 mA @ 10V DC
Fuses, Output	6 A slow blow or 10 A quick blow (external recommended)
Electrical Life (Operations)	220V AC/4 A/880V A cosφ = 0.35...0.1 M 220V AC/1.7 A/375V A cosφ = 0.6...0.5 M 30V DC/2 A/60 W = 1 M 10V DC/0.01 A/0.1 W = 2 M
Mechanical Life	10,000,000 cycles
Status Indicators	Output: Green = Output active

Output Utilization	
Resistive:	AC-1: 6 A/250V AC; DC-1: 6 A/24V DC
Inductive:	AC-15: 5 A/250V AC; DC-13: 3 A/30V DC
UL	B300, P300, 2 x 5 A or 3 x 4 A res 250V

Environmental and Physical Characteristics	
Enclosure Type Rating/ Terminal Protection	IP40 (NEMA 1)/ IP20
Operating Temperature [C (F)]	-5...+55 ° (23...131 °)
Vibration	10...55 Hz, 0.35 mm
Shock	10 g, 16 ms, 100 shocks
Mounting	35 mm DIN Rail
Weight [g (lbs)]	205 (0.45)
Conductor Size, Max.	0.2...2.5 mm <sup>2</sup> (24...12 AWG)

\* Usable for ISO 13849-1:2006 and IEC 62061. Data is based on the following assumptions:  
 - Mission time/Proof test interval of 20 years  
 - Functional test at least once within six-month period

**Product Selection**

Group No.	Safety Outputs	Auxiliary Outputs	Terminals	Reset Type	Power Supply	Cat. No.
1	3 N.O.	1 N.C.	Removable	—	24V DC from the base unit	440R-W23224
2						440R-W23225
3						440R-W23226

**Accessories**

Description	Cat. No.
Bag of 4, 4-Pin Screw Terminal Blocks	440R-A23209
Bag of 4, 4-Pin Spring Clamp Terminal Blocks	440R-A23228

**Approximate Dimensions**

Dimensions are shown in mm (in.). Dimensions are not intended to be used for installation purposes.

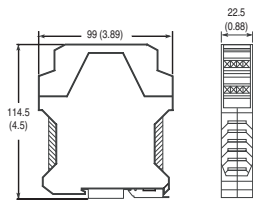

**Block Diagram**

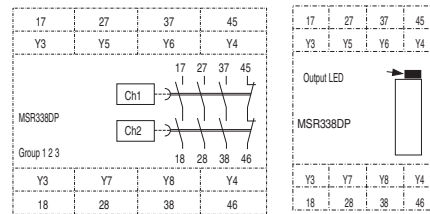

**Typical Wiring Diagrams**

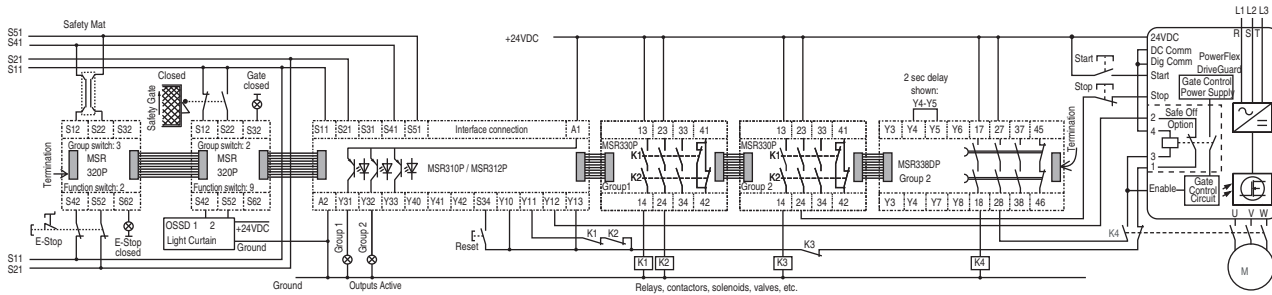

















MSR 300 system with various Inputs. Two Output Groups with common monitored reset, each Group with monitored contactors Safety Mat or E-Stop shut down both Groups, Safety Gate and Light Curtain only shut down the Group 2 modules: Controlled Stop via instant contacts, delayed Safe Off and Power removal via MSR338DP





**Off-Delay Time Table**

Delay(s)	Jumper	Jumper	All jumpers (links) on the terminals identified to achieve the desired off delay.					
			Delay(s)	Jumper	Jumper	Delay(s)	Jumper	Jumper
0	None	None	8	Y3-Y6	Y3-Y7	50	Y3-Y6	Y3-Y8
0.5	Y3-Y5	None	9	Y4-Y5	Y3-Y7	60	Y4-Y5	Y3-Y8
1	Y4-Y6	None	10	None	Y4-Y8	80	None	Y4-Y7
1.5	Y3-Y6	None	12	Y3-Y5	Y4-Y8	100	Y3-Y5	Y4-Y7
2	Y4-Y5	None	15	Y4-Y6	Y4-Y8	120	Y4-Y6	Y4-Y7
3	Y3-Y5	Y4-Y6	18	Y3-Y6	Y4-Y8	160	Y3-Y6	Y4-Y7
4	Y3-Y6	Y4-Y5	21	Y4-Y5	Y4-Y8	200	Y4-Y5	Y4-Y7
5	None	Y3-Y7	26	None	Y3-Y8	250	Y3-Y5, Y4-Y6	Y4-Y7
6	Y3-Y5	Y3-Y7	30	Y3-Y5	Y3-Y8	300	Y3-Y6, Y4-Y5	Y4-Y7
7	Y4-Y6	Y3-Y7	40	Y4-Y6	Y3-Y8			

Logic  
**Configurable Safety Relays**  
 Accessories

Accessories

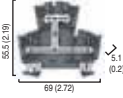
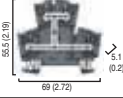
	Description	Cat. No.
	Fuse, 250 mA—Bussmann Cat. No. ETF-250mA 500 mA fuse—Bussmann Cat. No. ETF-500 mA Fuse, 1 A—Bussman Cat. No. ETF-1 Fuse, 2 A—Bussmann Cat. No. ETF-2	440A-A09196 440R-A31562 440R-A70972 440A-A09197
	MSR200, Two Terminators	440R-A17138
	MSR300 Two Terminators	440R-A17234
	Bag of 4, 4-Pin Screw Terminal Blocks	440R-A23209
	Bag of 4, 3-Pin Screw Terminal Blocks	440R-A23210
	Bag of 4, 4-Pin Spring Clamp Terminal Blocks	440R-A23228
	Bag of 4, 3-Pin Spring Clamp Terminal Blocks	440R-A23229
	Ribbon cable—for one MSR45E	<b>440R-ACABL1</b>
	Ribbon cable—for two MSR45Es	440R-ACABL2
	Ribbon cable—for three MSR45Es	440R-ACABL3
	Replacement terminal block kit—MSR41	440R-ATERM1P
	Replacement terminal block kit—MSR42	440R-ATERM2P
	Replacement terminal block kit—MSR45E	440R-ATERM2C
	USB optical interface software configuration tool used to configure the MSR42	445L-AF6150
	Replacement suction cup	445L-AF6151
	Optical interface fastener	445L-AF6152

Description	Cat. No.	
	24V DC power supply 2.1 A	1606-XLP50E
	24V DC power supply 3.0 A	1606-XLP72E
	24V DC power supply 5 A	1606-XL120D
	Non-illuminated, 40 mm Twist-to-release maintained mushroom (plastic)	800FP-MT44
	Non-illuminated, 40 mm Twist-to-release maintained mushroom (metal)	800FM-MT44
	Terminal Block with Diode (Forward)	<b>1492-JD3DF</b>
	Terminal Block with Diode (Reverse)	<b>1492-JD3DR</b>
	70 mm Tower Light Clear Module—Black Base (no bulb)	855T-B00XN7
	70 mm Tower Light Clear Module—Grey Base (no bulb)	855T-G00XN7
	70 mm Tower Light Clear Module—Black Base (LED)	855T-B24YL7
	70 mm Tower Light Clear Module—Grey Base (LED)	855T-G24YL7

## Programmable Safety Solutions Overview

Safety PLC systems bring the programmability and flexibility of traditional PLC systems to complex safety applications. Their programmable nature means that safety applications can now be solved in software rather than hard-wiring large, cascaded relay systems. This makes activities such as zone control and simplified machine access procedures much easier to achieve. Safety I/O modules are connected to Safety PLCs via safety certified networks, reducing wiring costs and allowing for advanced diagnostic information to be monitored by the safety PLC and shared with HMI systems. This results in reduced costs associated with wiring, troubleshooting and managing production equipment.

Benefits of safety PLCs include:

- **Flexibility.** Safety PLCs are programmable systems. This allows control engineers to easily design applications in which the behavior of the safety system can be flexible and based on the mode that the machine is currently operating in, the zone of the machine being accessed or the task that an operator or maintenance person is performing. This means that Safety PLCs can be used to help solve applications that are difficult if not impossible to solve with traditional safety relay systems.
- **Productivity.** The flexible programming of Safety PLCs permits control engineers to create maintenance modes of operation with “limited shutdown” capability, allowing for quicker access to production equipment and faster restart times, which help to reduce downtime. The extensive diagnostics also aid in the troubleshooting and repair of the system, improving MTTR (Mean Time to Repair) and further reducing downtime and improving productivity.
- **Wiring Simplification.** Safety input and output devices are wired directly to Safety I/O modules. These modules communicate to Safety PLCs via a single network cable. In applications that require logic or have safety devices distributed around equipment, Safety PLC systems can reduce the amount of wiring and commissioning effort required to install and start up production equipment.
- **Diagnostics.** Safety PLC systems perform internal and external diagnostics checks many times per second. Safety I/O modules also perform checks on their connected input and output devices. This information can be made easily available to operators and service personnel meaning that the exact source of a safety event can often be quickly identified and appropriate action taken, reducing MTTR, getting a machine back into production sooner.
- **Integration.** Safety PLCs enable machine makers to think of safety as part of the normal control of the machine, not just a piece that is added on at the end. Because safety PLCs communicate on standard automation networks, they allow for easy interlocking between the standard control system and the safety system. Some safety systems are so integrated, they can perform all of the standard machine control (sequential, motion, ...) plus safety control, all from one unit.
- **Reliability.** Safety PLC systems are designed specifically for very high MTBF (Mean Time Between Failure) and very low PFD (Probability of Failure on Demand).
- **Expandability.** Safety PLC systems are easily expanded. Additional I/O modules can be added to the system and application code can be easily modified and expanded by control engineers.
- **Security.** All safety PLCs have a “Safety Signature” associated with them, a unique identifier that changes whenever any part of the safety configuration or program is changed. This allows for quick spot checks to determine that the safety system is still the way it was when commissioned. Also, some safety PLCs have multiple layers of password protection to allow only authorized personnel to make changes.

- **Safety Certification.** Safety PLCs are designed to meet stringent standards for programmable safety systems. To demonstrate their compliance, they are certified by professional testing agencies that they meet the appropriate standard. All Rockwell Automation safety systems are certified by the TÜV Rheinland Group for use in applications up to SIL 3 per IEC 61508, and PLe/Category 4 per ISO 13849-1.

Typical applications for safety PLCs include (i) perimeter access control of production cells, robotic systems and complex manufacturing processes and lines, (ii) point of operation control for press and manual loading applications, and (iii) maintenance simplification, alternative methods for lockout/tagout and other applications where users want to streamline the service procedures for production equipment. Safety PLC systems typically consist of (i) a safety PLC where the user-designed application code is executed, (ii) safety I/O which is where safety input and output devices are wired, and (iii) a safety network that allows the safety PLC to communicate with the safety I/O and with each other. The safety PLC system provides you with an environment to write and execute application code with a very high safety integrity. You generate the application code that is executed in the safety PLC system and then, as part of the commissioning process, validate (test) that the safety PLC system mitigates the safety hazards that it was designed to monitor and control.

## Rockwell Automation Safety PLCs

Rockwell Automation manufactures three distinct families of safety PLCs and a variety of safety I/O modules.

### SmartGuard™ 600 Controllers

The SmartGuard 600 controller is designed for applications that require some complex logic. It is a “packaged safety controller” that includes the CPU, 16 Safety Inputs and 8 Safety Outputs and an embedded DeviceNet communications port all in one unit. Using the DeviceNet communications port, the SmartGuard 600 controller can control additional safety I/O modules including the 1791DS CompactBlock Guard I/O and 1732DS ArmorBlock Guard I/O, as well as 1734 POINT Guard I/O modules via a 1734-PDN module. In addition, the SmartGuard controller can also communicate with standard PLCs and HMIs on DeviceNet or EtherNet/IP networks. SmartGuard 600 systems are programmed using RSNetWorx for DeviceNet software. For more information on SmartGuard 600 controllers, see page 5-119.

### GuardPLC™ Controllers

GuardPLC refers to a family of safety controllers that are programmed with the RSLogix Guard PLUS software package. Like the SmartGuard 600, the GuardPLC 1600 and GuardPLC 1800 Safety PLCs are “packaged safety controllers” with a CPU, safety I/O and embedded communication networks. In the case of the GuardPLC 1600 and 1800 the embedded communication network is Ethernet for communication to GuardPLC Safety I/O modules as well as EtherNet/IP for communications to standard controllers and HMIs. The GuardPLC 1600 includes 20 safety inputs and 8 safety outputs. The GuardPLC 1800 includes 24 safety inputs, 8 safety outputs, 8 safety analog inputs and 2 safety rated high speed counters. For more information on GuardPLC controllers, see page 5-123.

### GuardLogix® Controllers

The GuardLogix system is a Logix5000™ controller that in addition to running all standard control functions like sequential, motion, etc., also has the ability to run a Safety Task and control safety I/O. This enables both safety and standard applications to run simultaneously in a single application project. This reduces integration, spare parts, training and improves the flow of data to HMI and information systems. A GuardLogix controller communicates to Guard I/O modules via standard control networks (EtherNet/IP or DeviceNet™) using the CIP Safety protocol. It is programmed with RSLogix™ 5000 software, just like a Logix5000™ processor. For more information on GuardLogix controllers, see page 5-133.



### Guard I/O™ Modules

Guard I/O is the name for the Rockwell Automation family of Safety I/O modules that communicate via CIP Safety on EtherNet/IP and DeviceNet networks. CompactBlock Guard I/O modules on DeviceNet networks are available in IP20 (in-cabinet) form-factor ArmorBlock Guard I/O modules on DeviceNet networks are available in IP67 (on-machine) form-factors. POINT Guard I/O modules provide EtherNet/IP connectivity in a maximum density in-cabinet I/O solution. For more information on Guard I/O modules, see page 5-137.

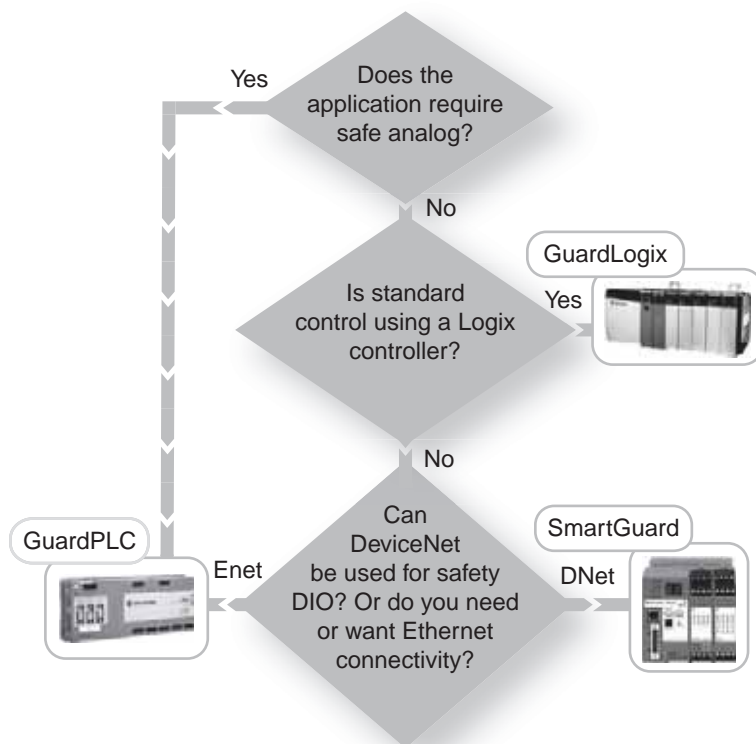
### Safety Logic Selection Flowchart



# Logic Overview

Product	 SmartGuard™ 600 (Bulletin 1752) page 5-119	 GuardPLC™ Controllers (Bulletin 1753) page 5-123	 GuardLogix® Controllers (Bulletin 1756) page 5-133
<b>Form Factor</b>	<ul style="list-style-type: none"> <li>• Standalone</li> </ul>	<ul style="list-style-type: none"> <li>• Standalone</li> </ul>	<ul style="list-style-type: none"> <li>• ControlLogix® Chassis (1756 GuardLogix controller)</li> <li>• 1768 CompactLogix (1768 Compact GuardLogix controller)</li> </ul>
<b>Safety Communication Network</b>	<ul style="list-style-type: none"> <li>• DeviceNet™ (on-board)</li> </ul>	<ul style="list-style-type: none"> <li>• GuardPLC Ethernet (on-board)</li> </ul>	<ul style="list-style-type: none"> <li>• DeviceNet and EtherNet/IP via 1756-based communication bridges</li> </ul>
<b>Standard Communication Network</b>	<ul style="list-style-type: none"> <li>• DeviceNet (on-board)</li> <li>• EtherNet/IP (on-board 1752-L24BBBE)</li> </ul>	<ul style="list-style-type: none"> <li>• EtherNet/IP (on-board)</li> <li>• Profibus or Modbus (on-board)</li> </ul>	<ul style="list-style-type: none"> <li>• Many via 1756-based or 1768-based communication bridges</li> </ul>
<b>Programming Network</b>	<ul style="list-style-type: none"> <li>• DeviceNet (on-board)</li> <li>• USB (on-board)</li> <li>• EtherNet/IP (on-board 1752-L24BBBE)</li> </ul>	<ul style="list-style-type: none"> <li>• GuardPLC Ethernet (on-board)</li> </ul>	<ul style="list-style-type: none"> <li>• EtherNet/IP, ControlNet, DeviceNet via 1756-based or 1768-based communication bridges</li> </ul>
<b>Programming Editor</b>	<ul style="list-style-type: none"> <li>• RSNetWorx™ for DeviceNet™ Software</li> </ul>	<ul style="list-style-type: none"> <li>• RSLogix Guard PLUS! Software</li> </ul>	<ul style="list-style-type: none"> <li>• RSLogix™ 5000 Software</li> </ul>
<b>Discrete Safety I/O</b>	<ul style="list-style-type: none"> <li>• 16 safety inputs/8 safety outputs (on-board)</li> <li>• Guard I/O (remote via DeviceNet network)</li> </ul>	<ul style="list-style-type: none"> <li>• 20 or 24 safety inputs/8 safety outputs</li> <li>• GuardPLC I/O (remote via GuardPLC Ethernet)</li> </ul>	<ul style="list-style-type: none"> <li>• Guard I/O™ (remote via DeviceNet or EtherNet/IP networks)</li> </ul>
<b>Safety Analog Input</b>	N/A	<ul style="list-style-type: none"> <li>• 8 safety analog inputs (on-board GuardPLC 1800)</li> <li>• 8 safety analog inputs (remote via GuardPLC I/O Module)</li> </ul>	N/A
<b>High Speed Counter</b>	N/A	<ul style="list-style-type: none"> <li>• 2 high speed counter inputs (on-board GuardPLC 1800)</li> </ul>	N/A



**Description**

The SmartGuard 600 safety controller is a programmable safety controller designed for safety applications that require some complex logic allowing for more advanced safety functionality. It features 16 safety-rated inputs, 8 safety-rated outputs, 4 pulse test sources and an optional EtherNet/IP™ port. To support both standard CIP and CIP safety, a DeviceNet™ connection is also included. Configuration and programming is accomplished on EtherNet/IP, DeviceNet, or through the built-in USB port.

Since the SmartGuard 600 safety controller is a safety master on the DeviceNet network, you can use Rockwell Automation Guard I/O™ modules to expand the number of safety devices the SmartGuard 600 controller can control. It can also perform safety interlocking between a GuardLogix or other SmartGuard 600 controllers. With your choice of EtherNet/IP™ or DeviceNet™ communication, other devices such as standard PLCs and HMIs can read data out of the SmartGuard 600 controller for system-level diagnostics and troubleshooting.

Use RSNetWorx™ for DeviceNet™ software to configure the network and program the controller. From within RSNetWorx for DeviceNet software, you can launch an editor that lets you write function block programs for the SmartGuard 600 controller. No additional programming software is required. With ten safety application instructions, plus another dozen logic and timing instructions, you can write powerful, yet simple safety control programs.

**Benefits**

- Small, cost-effective, intelligent safety controller
- Ideal mid-level safety controller when the application is too complex for a safety relay, yet too simple for a full-sized safety PLC
- Use the DeviceNet network to distribute safety I/O and integrate into a standard control system
- Use RSNetWorx for DeviceNet software for configuration and programming — no special programming software required

**Networking with SmartGuard 600 Controllers**

The SmartGuard 600 controller can function simultaneously as a DeviceNet safety master, DeviceNet safety slave, and DeviceNet standard slave as well as an EtherNet/IP target (see network illustration).

- As a DeviceNet safety master (1), the SmartGuard 600 controller can control up to 32 Guard I/O modules. These 1791DS and 1732DS modules are the same distributed safety I/O modules used with GuardLogix controllers.
- As a DeviceNet safety slave (2), the SmartGuard 600 controller looks like distributed safety I/O to a safety master. A GuardLogix or another SmartGuard safety master can read and write safety data to the SmartGuard slave controller. This lets you perform distributed safety control through the interlocking of multiple controllers via CIP Safety on DeviceNet networks.
- As a DeviceNet standard slave (3), the SmartGuard 600 controller can look like a standard distributed I/O module and respond to explicit messages so that standard DeviceNet masters like ControlLogix, SLC 500, or PLC-5 controllers or an HMI can read and write information to and from the SmartGuard 600 controller. This facilitates coordination with your standard PLC application, including displaying safety system information on an HMI.
- As an EtherNet/IP standard target (4), the SmartGuard 600 controller communicates with an Ethernet/IP standard originator, such as a CompactLogix or MicroLogix controller or an HMI device.
- As a limited EtherNet/IP bridge device (5), the SmartGuard 600 controller lets programming tools bridge to DeviceNet to view and program the SmartGuard 600 controller and configure other DeviceNet devices.

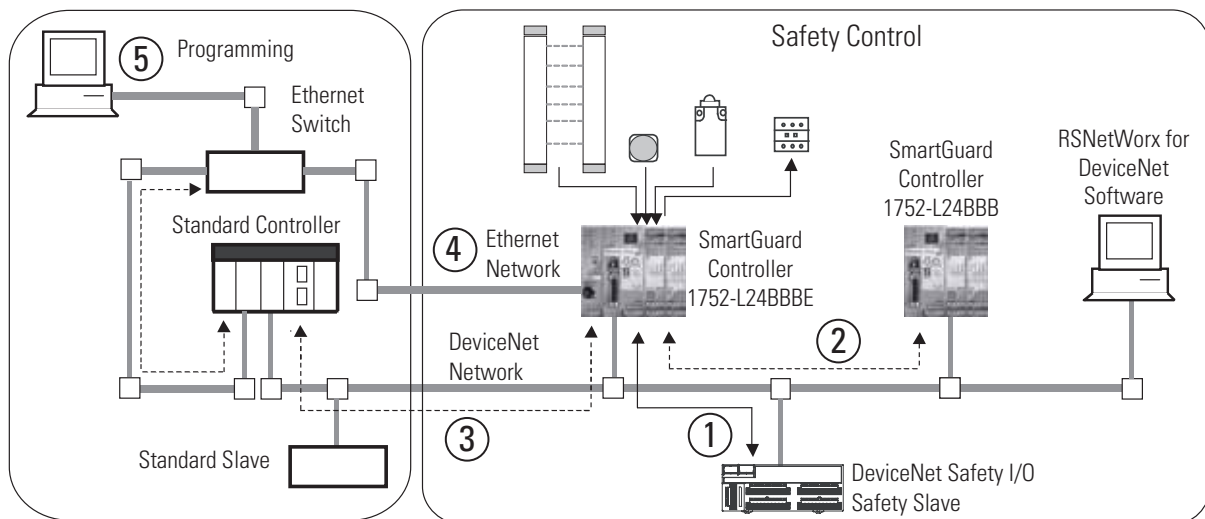

5-Programmable Safety Solutions

### Configuration and Programming

You can program and configure the SmartGuard 600 controller through its USB port, through a DeviceNet connection or through an Ethernet connection. The SmartGuard's USB port has limited pass-through capabilities, letting you configure other devices on DeviceNet networks. You can use any type of A-to-B connection USB cable that supports USB 1.x or 2.0. Alternatively, you can connect to the SmartGuard controller through its DeviceNet port via a PCD card or a PC connected to an EtherNet/IP-to-DeviceNet linking device or gateway. You can also connect the 1752-L24BBBE SmartGuard controller to a PC's Ethernet port using a Category 5 Ethernet cable.

### Safety System Management

Multiple system management tools are built into the SmartGuard 600 controller and RSNetWorx for DeviceNet software.

- You can password-protect the entire SmartGuard 600 controller so you cannot download any changes without the password. You can also password-protect the program with a separate password, to help prevent unauthorized edits to the program.
- Each safety device contains a configuration signature that changes any time the DeviceNet configuration or SmartGuard program changes, even if it is changed back to its original state. The configuration signature can be read by external devices, such as standard PLCs, HMI, or asset management software, to determine whether the configuration or program has been changed.
- Lastly, you can use the Safety Device Verification Wizard in RSNetWorx for DeviceNet software to safety-lock the SmartGuard 600 controller. Safety-locking via the Safety Device Verification Wizard verifies that the offline and online configuration and program are identical and provides documentation that you can keep in your files to show that the controller has not been tampered with.

### Typical Applications

The SmartGuard 600 controller is positioned between a safety relay system and a safety PLC. It is ideally sized for applications that cannot be solved with safety relays, or are very cumbersome to solve with relays, but are not complex enough for a traditional safety PLC like a GuardLogix® or GuardPLC™ controller.

- Applications where a safety relay solution (or configurable safety relay solution) is just too complex
- Applications that require distributed safety I/O and/or network integration with a standard PLC
- Applications where GuardLogix or GuardPLC controllers seem too big (or are not cost-effective)
- Applications that require multi-zone control
- Complex light curtain applications; for example, implementing light curtain muting when a robot is not in the operator load zone and monitoring an enable pendant that lets the operator enter the zone with the robot present.

### Catalog Numbers and Related Products

Cat. No.	Product Description
1752-L24BBB	SmartGuard 600 Safety Controller
1752-L24BBBE	SmartGuard 600 Controller with EtherNet/IP
9357-DNETL3	RSNetWorx for DeviceNet*
9355-WAB100ENE	RSLinx Classic (Lite)*

\* 1752-L24BBB requires version 8 (minimum) or version 9.1 (recommended); 1752-L24BBBE requires version 9.1 or later

\* 1752-L24BBB requires version 2.51 or later; 1752-L24BBBE requires version 2.55 or later

### Specifications

#### Environmental Specifications and Certifications

Cat. No.	1752-L24BBB	1752-L24BBBE
Operating Temperature	-10...55 °C (14...131 °F)	
Non-Operating Temperature	-40...70 °C (-40...158 °F)	
Relative Humidity	10...95% noncondensing	
Vibration	0.35 mm @ 10...57 Hz 5 g @ 57...500 Hz	5 g @ 10...500 Hz
Shock, Operating	15 g	
Certifications*	UL, CE, C-Tick, cULus Class I Div 2 Hazardous, UL NRGF, NFPA 79, certified by TÜV for Functional Safety up to SIL 3, and PLe/Cat. 4	

\* When product is marked. See the Product Certification link at <http://www.ab.com/certification> for Declarations of Conformity, Certificates, and other certification details.

#### Controller Specifications

Cat. No.	1752-L24BBB	1752-L24BBBE
Supply Voltage	20.4...26.4V DC (24V DC, -15...10%)	20.4...26.4V DC (24V DC, -15...10%)
Input Voltage Range	11...25V DC DeviceNet Specification	11...25V DC DeviceNet Specification
DeviceNet Current (mA)	15 mA	15 mA
Current Consumption	230 mA @ 24V DC	280 mA @ 24V DC
<b>Digital Inputs</b>		
Number of Digital Inputs	16	16
Voltage, On-State Input, Min.	11V DC	11V DC
Voltage, Off-State Input, Max.	5V DC	5V DC
Current, Off-State Input, Max.	1 mA	1 mA
Current, On-State Input, Nom.	4.5 mA	4.5 mA
<b>Digital Outputs</b>		
Number of Digital Outputs	8	8
Output Current Rating	0.5 A	0.5 A
Voltage, Off-State Output, Max.	1.2V	1.2V
Leakage Current, Off-State Output, Max.	0.1 mA	0.1 mA
<b>Pulse Test Sources</b>		
Number of Pulse Test Sources	4	4
Pulse Test Output Current	0.7 A	0.7 A
Pulse Test Voltage, Off-State Output, Max.	1.2V	1.2V
Pulse Test Output Leakage Current, Max.	0.1 mA	0.1 mA
<b>General</b>		
Dimensions (HxWxD), Metric	99.0 x 90.4 x 131.4 mm	99.0 x 113.0 x 131.4 mm
Dimensions (HxWxD), Imperial	3.90 x 3.56 x 5.18 in.	3.90 x 4.48 x 5.18 in.
Weight, Metric	470 g	575 g
Weight, Imperial	1.03 lb	1.27 lb

**Typical SmartGuard 600 System Architectures**

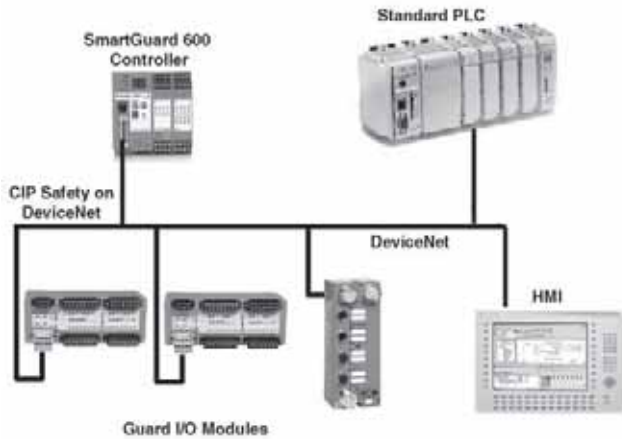

*SmartGuard 600 controller (1752-L24BBB) on a DeviceNet network.*

**RSNetWorx™ for DeviceNet™ Software Description**

RSNetWorx™ for DeviceNet™ software is the premier configuration software for your Open DeviceNet Vendor Association DeviceNet network; it provides configuration management and diagnostic features, and it is one of the most advanced DeviceNet network management software packages available today. RSNetWorx Software for DeviceNet Network helps you achieve maximum productivity with your DeviceNet installations.

You can quickly define the devices on your DeviceNet network and the input/output exchanges that take place through this simple software interface.

RSNetWorx for DeviceNet software supports configuration of DeviceNet Safety devices. A Safety Device Verification Wizard guides you through the verification and configuration locking process and provides a report listing the configuration information for all of the safety devices on the network.

RSNetWorx Software for DeviceNet contains the editor used to program the SmartGuard 600 controller. Once you have configured your network containing a SmartGuard 600 controller, you launch the editor, which lets you write function block programs. No additional programming software is needed!

Cat. No.	Description
9357-DNETL3	RSNetWorx for DeviceNet

**Benefits**

- Define the devices that are present on your network. You can either manually drag/drop devices/modules or go online to a DeviceNet network and let the software determine the devices/modules that are present.
- Define configuration settings for devices on the DeviceNet network through a convenient property page interface.
- Define the input/output information exchanges that you want to take place on the DeviceNet network.
- Access a comprehensive product tutorial to help you get the most value from the software as quickly as possible.
- Receive troubleshooting hints whenever error messages are presented, making you more productive.
- Configure and exchange data with DeviceNet Safety Scanner and DeviceNet Safety I/O nodes.
- Verify and lock safety devices for use in high-integrity safety systems.

**System Requirements**

RSNetWorx software can be used with these operating systems:

- Microsoft Windows Vista
- Microsoft Windows XP
- Microsoft Windows 2000

**RSNetWorx for DeviceNet Software Examples**



*Use RSNetWorx for DeviceNet software to configure all of your DeviceNet devices, including SmartGuard 600 controllers and Guard I/O modules.*

# SmartGuard™ 600 Controller

RSNetWorx for DeviceNet Software/Guard I/O Modules



The Properties page for the SmartGuard 600 controller allows you to configure all of its parameters including I/O tags, I/O discrepancy times, connections to Guard I/O modules, and data that can be read by standard controllers or HMIs.

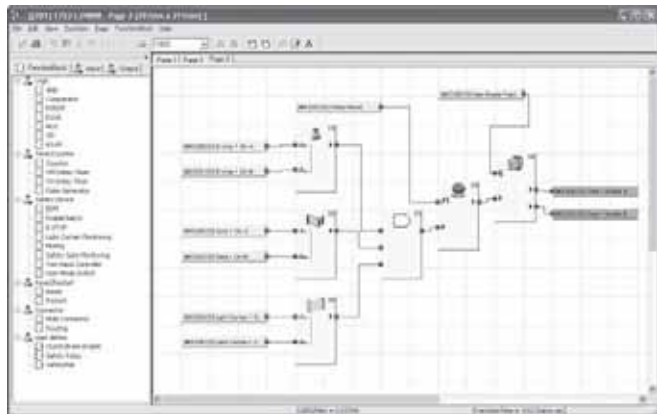

By clicking on the 'Logic' tab on the Properties dialog, RSNetWorx for DeviceNet software launches the editor for the SmartGuard 600 controller where you create your program using safety instructions, basic logic, timers, and counters. You also have the ability to create your own instructions.

## Guard I/O™ Modules



When the SmartGuard 600 controller needs additional safety I/O points, you can control and monitor your safety device with Guard I/O. When used with SmartGuard controllers, Guard I/O communicates on DeviceNet using CIP Safety protocol. As a proven technology, Guard I/O detects failures at the I/O and field device level, while enhancing operator protection.

CompactBlock Guard I/O modules are available in IP20 (in-cabinet) form factor. ArmorBlock Guard I/O modules are IP67 (on-machine) form factor. POINT Guard I/O provides maximum I/O density in minimal panel space (used in conjunction with a 1734-PDN adapter on a DeviceNet network).

For more information on Guard I/O see page 5-137.

### System Overview



The GuardPLC system is a state-of-the-art safety system offering fast safety PLCs, optimum controller throughput, and a reliable safety network.

The GuardPLC system meets the worldwide standard for programmable controls, complying with many of the latest global safety standards and the worldwide standard for functional safety in programmable electronic systems. The GuardPLC system can be used without restriction in applications up to Safety Integrity Level 3 (SIL 3) according to IEC 61508 and PLE/Category 4, according to ISO 13849-1.

The GuardPLC system consists of four main components:



- Packaged controller and associated integrated I/O
- Safety Communication via GuardPLC Ethernet networks
- Distributed I/O modules for GuardPLC Ethernet networks
- Programming and configuration software

### Benefits

Benefits resulting from the use of safety PLCs and safety networks include:

- Greater integration and flexibility of machine controls.
- Capability for better and easier diagnostics when intelligence is provided to the standard control level
- Faster and easier maintenance
- Reduction in the cost of installation, commissioning, and reconfiguring
- Reduction in design and hardware costs, compared to using safety relays alone for logic
- Potential for throughput performance improvement in more complex systems

### GuardPLC Safety Control Systems

	 GuardPLC 1600 5-125	 GuardPLC 1800 5-127	 GuardPLC Distributed I/O 5-129
<b>Description</b>	A cost-effective safety PLC offering a built-in 4-port Ethernet switch, digital I/O, and flexible communication options for connecting devices.	Analog inputs and high-speed counters allow the GuardPLC 1800 to sense temperature, pressure, speed, and motion.	Distributed safety I/O blocks provide exceptional flexibility in configuring the right mix of I/O in the right place.
<b>Memory</b>	<ul style="list-style-type: none"> <li>• 250kB user program</li> <li>• 250kB application data</li> </ul>	<ul style="list-style-type: none"> <li>• 250kB user program</li> <li>• 250kB application data</li> </ul>	—
<b>Digital I/O</b>	<ul style="list-style-type: none"> <li>• 20 inputs</li> <li>• 8 outputs</li> </ul>	<ul style="list-style-type: none"> <li>• 24 inputs</li> <li>• 8 outputs</li> </ul>	<ul style="list-style-type: none"> <li>• 16 inputs only</li> <li>• 16 outputs only</li> <li>• 8 inputs and 8 outputs</li> <li>• 16 inputs and 8 outputs</li> <li>• 20 inputs and 8 outputs</li> </ul>
<b>Other I/O</b>	—	<ul style="list-style-type: none"> <li>• 8 analog inputs</li> <li>• 2 high-speed counters</li> </ul>	<ul style="list-style-type: none"> <li>• 8 analog inputs</li> <li>• 8 relay outputs</li> </ul>
<b>Embedded Ethernet</b>	4-port switch	4-port switch	2-port switch
<b>Other Communications</b>	<ul style="list-style-type: none"> <li>• EtherNet/IP</li> <li>• GuardPLC Ethernet</li> <li>• Modbus RTU Slave or PROFIBUS DP Slave</li> <li>• ASCII (RS-485)</li> </ul>	<ul style="list-style-type: none"> <li>• EtherNet/IP</li> <li>• GuardPLC Ethernet</li> <li>• Modbus RTU Slave or PROFIBUS DP Slave</li> <li>• ASCII (RS-485)</li> </ul>	<ul style="list-style-type: none"> <li>• GuardPLC Ethernet</li> </ul>
<b>Programming Software</b>	All GuardPLC controllers are programmed with RSLogix Guard PLUS! programming software.		

# GuardPLC™ Safety Control Systems

## Overview

### Communication

GuardPLC safety controllers communicate on a Safe Ethernet communications network called GuardPLC Ethernet. The network is certified by TÜV for use in safety applications up to SIL 3 and PLe/Category 4, and can be used for distributed safety I/O and peer-to-peer communications between GuardPLC controllers, as well as programming using RSLogix Guard PLUS! software. And because it's Ethernet, you use standard category 5 cables, switches and routers.

Using GuardPLC distributed I/O, you can place your safety I/O where your safety field devices are located, reducing wiring costs. Peer-to-peer communications allow GuardPLC controllers running their own programs to interlock with each other for applications that need to link one manufacturing cell to others.

The first level of integrating your GuardPLC controller into your standard control system is at the information network level. The GuardPLC 1600 and 1800 controllers let you to accomplish this easily with embedded EtherNet/IP protocol. Able to run EtherNet/IP protocol at the same time as safety-rated GuardPLC Ethernet protocol, the GuardPLC controller uses EtherNet/IP protocol to communicate status about the safety control system to other standard devices such as PLCs (ControlLogix®, FlexLogix™, CompactLogix™, SLC™ 500 or PLC-5®), HMIs (PanelView™, PanelView Plus, VersaView®) and others. The GuardPLC controller can even control standard I/O, like Flex I/O and Point I/O, on an EtherNet/IP network. This capability lets you integrate your GuardPLC on the EtherNet/IP network already running in your plant.

### NetLinX Integration

The ever-increasing demand for both enhanced plant productivity and improved workplace safety has fueled a trend toward integrated safety control and standard control systems. Control system users now expect their safety systems to possess all of the efficiencies and conveniences of their standard controls. Today's modern manufacturing plants will not accept safety systems that compromise productivity. Both machine builders and end users expect that the cost of implementing and maintaining a safety system will continue to drop without reducing the level of protection to the user.

### GuardPLC Typical Configuration

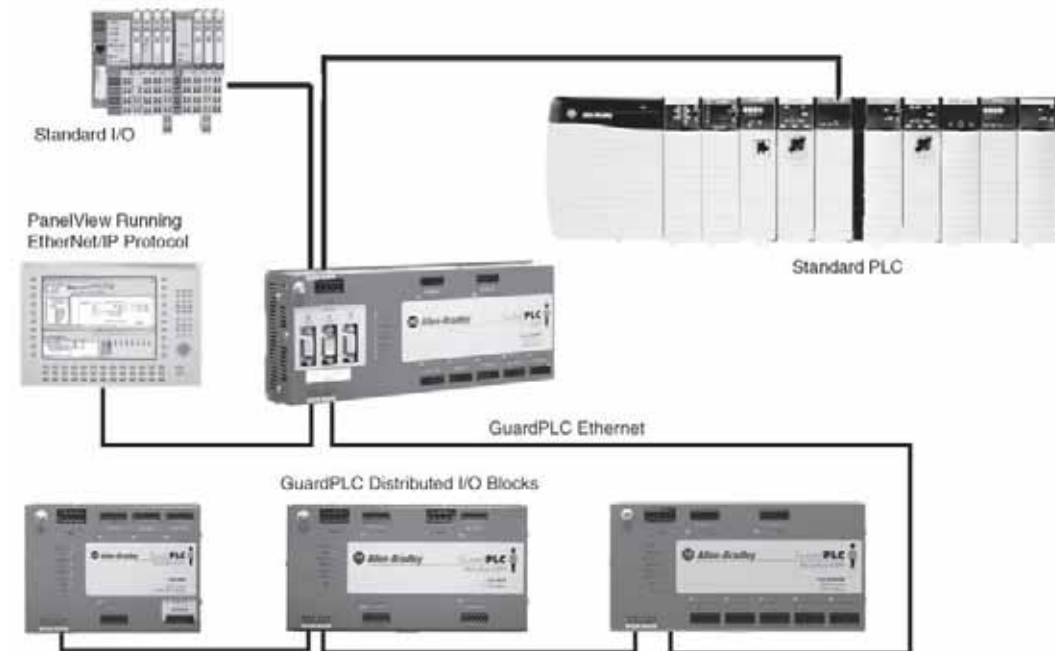

5-Programmable Safety Solutions

## GuardPLC 1600 Controller



The GuardPLC 1600 controller is a mainstream, cost-effective safety PLC that provides onboard digital I/O, a built-in 4-port Ethernet switch, and flexible communication options for connection to HMIs and to standard PLCs.

### Benefits

- 28 safety digital I/O points – designed specifically for interfacing with safety components such as e-stops, light curtains, etc.
- Embedded 4-port Ethernet switch – eliminates the need for external networking hardware, reducing system cost.
- EtherNet/IP for easy integration with standard PLCs and HMIs.
- Modbus RTU slave and PROFIBUS DP slave communication options – allow the controller to connect to standard PLCs and HMI devices, and an RS-485 port is available for ASCII communication (read only).
- Expandability – use GuardPLC Distributed I/O to cost-effectively expand your safety system.
- Removable terminal blocks – make swapping controllers an efficient task so operations can be up and running again quickly in the event of a failure.

### Typical Applications

- Perimeter guarding for robot / weld cells
- Perimeter guarding for packaging machines
- Press controls
- Semiconductor tools
- Material handling systems

### Product Design

The GuardPLC 1600 controller features a built-in four-port Ethernet switch and digital I/O (20 safety rated inputs and eight safety rated outputs). 100M GuardPLC Ethernet comes standard, plus for flexibility in connecting to HMI devices and standard PLCs, the controller includes EtherNet/IP, Modbus RTU Slave or PROFIBUS DP Slave, an RS-485 port for ASCII communications.

At 10 ms throughput, this controller is one of the fastest safety PLCs in the industry. Its exceptionally high mean time between failures helps increase the safety and reliability of your system. Removable terminal blocks make swapping controllers a quick task so operations can be up and running again quickly in the event of failure.

### Features

- 28 digital I/O points: 20 inputs, 8 outputs
- Use GuardPLC Distributed I/O to expand safety system
- EtherNet/IP, RS-485 port for ASCII communication (read only)
- Embedded 4-port Ethernet switch eliminates the need for external networking hardware
- Modbus RTU slave and PROFIBUS DP slave communication options to connect to standard PLCs and HMI devices
- Certified by TÜV for use in applications to SIL 3 according to IEC 61508 and PLe/Category 4, according to ISO 13849-1
- Programmed with RSLogix Guard PLUS! Software
- DIN rail mounting
- Cost-effective safety control system

**Specifications**

**General Specifications**

The following specifications are common to all GuardPLC products unless indicated.

Temperature, operating	0...60 °C (32...140 °F)
Temperature, nonoperating	-40...85 °C (-40...185 °F) without backup battery
Relative Humidity	95%
Vibration	1 g @ 10...150 Hz
Shock, operating	15 g

**Certifications**

(When product is marked.)

Certifications	GuardPLC 1600, GuardPLC 1800, and 1753 I/O
c-UL-us	c-UL Listed Industrial Control Equipment.
CE	Compliant for all applicable directives.
C-Tick	C-Tick compliant with all applicable acts
Functional Safety	certified by TÜV up to SIL 3, and PLe/Cat. 4

**GuardPLC 1600 Controller Specifications**

Cat. No.	1753-L28BBBM	1753-L28BBBP
Application Memory	250 KB	
User Program Memory	250 Kbytes	
Available User Memory	500	
Current Consumption	8 A with maximum load 0.5 A idle current (controller only)	
Operating Voltage Range	24V DC, -15% to +20%, $w_{ss} \leq 15\%*$	
Communication Ports	4 Ethernet 10/100BaseT ports 1 9-pin D-shell RS-485 port (Modbus Slave) 1 9-pin D-shell RS-485 port (GuardPLC ASCII) 1 9-pin D-shell Comm port (unused)	4 Ethernet 10/100BaseT ports 1 9-pin D-shell RS-485 port (PROFIBUS DP Slave) 1 9-pin D-shell RS-485 port (GuardPLC ASCII) 1 9-pin D-shell Comm port (unused)
Ethernet Port	4 x RJ-45, 10/100BaseT (with 100 Mbit/s) with integrated switch	
EtherNet/IP Communication Rate	10/100 Mbps	
Enclosure Protection	IP20	
<b>Digital Inputs</b>		
Number of Digital Inputs	20 safety <sup>‡</sup>	
Voltage, On-State Input, Max.	30V DC	
Voltage, On-State Input, Nom.	24V DC	
<b>Digital Outputs</b>		
Number of Digital Outputs	8 safety <sup>‡</sup>	
Current, On-State Output, per Channel	Channels 1...3; 5...7: 0.5 A @ 60 °C (140 °F) Channels 4 and 8: 1 A @ 60 °C (140 °F); 2 A @ 50 °C (122 °C)	
Voltage, On-State Output, Max.	26.8V DC	
Voltage, On-State Output, Min.	18.4V DC	
Voltage, On-State Output, Nom.	24V DC	
<b>General</b>		
Dimensions (HxWxD), Metric	114 x 257 x 78 mm <sup>‡</sup>	
Dimensions (HxWxD), Imperial	4.49 x 10.1 x 3.07 in <sup>‡</sup>	

\* Requires a power supply with protective separation conforming to IEC 61131-2 requirements.

<sup>‡</sup> Not electrically isolated.

<sup>‡</sup> Height includes latch; width includes housing screws; depth includes grounding bolt and connectors.

## GuardPLC 1800 Controller



The GuardPLC 1800 controller takes all the features of the GuardPLC 1600 controller, then adds analog inputs and high-speed counters for specialized applications such as emergency shut down, flame control, and amusement park ride control.

### Benefits

- 32 safety digital I/O points – designed specifically for interfacing with safety components such as e-stops and light curtains.
- 8 safety-rated analog inputs – for sensing temperature, pressure, etc.
- 2 safety-rated high-speed counters – for sensing speed, flow, and motion.
- Embedded 4-port Ethernet switch – eliminates the need for external networking hardware.
- Supports EtherNet/IP protocol for easy integration with standard PLCs and HMIs.
- Modbus RTU slave and PROFIBUS DP slave communication options – lets the controller connect to standard PLCs and HMI devices, and an RS-485 port is available for ASCII communication (read only).
- Expandability – Use GuardPLC Distributed I/O to expand your safety system.
- Removable terminal blocks – make swapping controllers an efficient task so operations can be up and running again quickly in the event of a failure.

### Typical Applications

- Emergency shutdown
- Burner management systems
- Perimeter guarding for robot / weld cells
- Perimeter guarding for packaging machines

### Product Design

The GuardPLC 1800 controller has the same features as the GuardPLC 1600 controller with additional I/O, including analog I/O and high-speed counters for specialty applications. Built-in I/O includes 24 digital inputs, 8 digital outputs, 8 analog inputs, plus 2 high-speed counters. With GuardPLC distributed I/O you can place additional safety I/O where your safety field devices are located, reducing wiring costs.

The GuardPLC 1800 offers a built-in four-port Ethernet switch and 100M GuardPLC Ethernet comes standard. For flexibility in connecting to HMI devices and standard PLCs, the controller includes EtherNet/IP, Modbus RTU Slave or PROFIBUS DP Slave, an RS-485 port for ASCII communications.

At 10 ms throughput, this controller is one of the fastest safety PLCs in the industry. Its exceptionally high mean time between failures helps increase the safety and reliability of your system. Removable terminal blocks make swapping controllers a quick task so operations can be up and running again quickly in the event of failure.

### Features

- 32 digital I/O points: 24 inputs, 8 outputs
- 8 analog inputs
- 2 high-speed counters
- EtherNet/IP for easy integration with standard PLCs and HMIs.
- Modbus RTU slave and PROFIBUS DP slave communication options – allow the controller to connect to standard PLCs and HMI devices, and an RS-485 port is available for ASCII communication (read only).
- Programmed with RSLogix Guard PLUS! software
- Certified by TÜV for use in applications to SIL 3 according to IEC 61508 and PLe/Category 4, according to ISO 13849-1
- DIN rail mounting

### Specifications

#### General Specifications

The following specifications are common to all GuardPLC products unless indicated.

Temperature, operating	0...60 °C (32...140 °F)
Temperature, nonoperating	-40...85 °C (-40...185 °F) without backup battery
Relative Humidity	95%
Vibration	1 g @ 10...150 Hz
Shock, operating	15 g

Logic

# GuardPLC™ Safety Control Systems

## GuardPLC 1800 Controller

### Certifications

(When product is marked.)

Certifications	GuardPLC 1600, GuardPLC 1800, and 1753 I/O
c-UL-us	c-UL Listed Industrial Control Equipment.
CE	Compliant for all applicable directives.
C-Tick	C-Tick compliant with all applicable acts
Functional Safety	certified by TÜV up to SIL 3, and PLe/Cat. 4

### GuardPLC 1800 Controller Specifications

Cat. No.	1753-L32BBBM8A	1753-L32BBBP8A
Application Memory	250 KB	
User Program Memory	250 Kbytes	
Available User Memory	500	
Current Consumption	9 A with maximum load 0.75 A idle current (controller only)	
Operating Voltage Range	24V DC, -15% to +20%, $w_{ss} \leq 15\%$ *	
Communication Ports	4 Ethernet 10/100BaseT ports 1 9-pin D-shell RS-485 port (Modbus Slave) 1 9-pin D-shell RS-485 port (GuardPLC ASCII) 1 9-pin D-shell Comm port (unused)	4 Ethernet 10/100BaseT ports 1 9-pin D-shell RS-485 port (PROFIBUS DP Slave) 1 9-pin D-shell RS-485 port (GuardPLC ASCII) 1 9-pin D-shell Comm port (unused)
Ethernet Port	4 RJ-45	
EtherNet/IP Communication Rate	10/100 Mbps	
Enclosure Protection	IP20	
<b>Digital Inputs</b>		
Number of Digital Inputs	24 safety*	
Voltage, On-State Input, Max.	30V DC	
Voltage, On-State Input, Nom.	24V DC	
<b>Digital Outputs</b>		
Number of Digital Outputs	8 safety*	
Current, On-State Output, per Channel	Channels 1...3; 5...7: 0.5 A @ 60 °C (140 °F) Channels 4 and 8: 1 A @ 60 °C (140 °F); 2 A @ 50 °C (122 °C)	
Voltage, On-State Output, Max.	Supply Voltage (L+)	
Voltage, On-State Output, Min.	Supply Voltage (L+) minus 2V	
Voltage, On-State Output, Nom.	24V DC	
<b>Counters</b>		
Number of Counters	2 safety*	
Counter Resolution, Bits	24 bits	
Counting Frequency (kHz), Max.	100	
Inputs per Counter	3 (A, B, Z)	
<b>Analog Inputs</b>		
Number of Analog Inputs	8 safety‡	
Input Resolution	12-bit	
Input Signal Range	0...10V DC (nominal); -0.1...11.5V DC (service value) 0...20 mA (nominal); 0.4...23 mA (service value)§	
Accuracy	0.1% @ 25 °C (77 °F) 0.5% @ 60 °C (140 °F)	
Safety Accuracy	± 2%	
<b>General</b>		
Dimensions (HxWxD), Metric	114 x 257 x 81 mm♣	
Dimensions (HxWxD), Imperial	4.49 x 10.1 x 3.19 in♣	

\* From a power supply with protective separation conforming to IEC 61131-2 requirements.

‡ Not electrically isolated.

‡ Unipolar, not electrically isolated.

§ With 500 Ω shunt.

♣ Height including latch; width including housing screws; depth including grounding bolt and shield plate.

# GuardPLC™ Safety Control Systems

## Distributed Safety I/O for GuardPLC Ethernet

### Distributed Safety I/O for GuardPLC Ethernet



Take advantage of all the benefits of traditional distributed I/O with GuardPLC distributed safety I/O, available for all GuardPLC systems.

GuardPLC distributed I/O modules provide considerable flexibility in configuring the right mix of I/O in the right place. The 16 digital input module offers 4 pulse test source terminals, allowing users to pulse test all 16 digital inputs from the I/O module and providing PLe/Category 4 capable safety circuitry while retaining all the

advantages of distributed I/O. The 16 digital output module is rated for 2A on every other output point, limiting the need for additional interposing safety relays for additional current and therefore saving on machine costs.

The safety relay output module can provide dry contact enable signals as well as high current AC or DC outputs. The 8 input/8 output and 16 input/8 output digital combination modules feature both positive and negative switching outputs, for applications that use diverse outputs. The analog input module lets you distribute analog inputs for more process-oriented safety applications.

All I/O modules include GuardPLC 100 Mbps Ethernet, which provides one of the fastest safety networks and machine stop times in the industry. The built-in two-port Ethernet switches make connecting I/O modules to the GuardPLC controller as easy as daisy-chaining Ethernet cable from I/O module to controller.

### Benefits

- Place the I/O where the devices reside.
- Reduce wiring costs and the time necessary to wire the machine or cell.
- Reduce machine or cell start up time.
- Increase machine and cell reliability.

### Digital Safety I/O Module Specifications

Cat. No.	1753-IB16	1753-IB8XOB8	1753-IB16XOB8	1753-IB20XOB8	1753-OB16
Description	GuardPLC Digital Input Module	GuardPLC Digital Combination Module	GuardPLC Digital Combination Module	GuardPLC Digital Combination Module	GuardPLC Digital Output Module
Operating Voltage Range	24V DC, -15%...+20%, W <sub>SS</sub> 15%*	24V DC, -15%...+20%, W <sub>SS</sub> 15%*	24V DC, -15%...+20%, W <sub>SS</sub> 15%*	24V DC, -15%...+20%, W <sub>SS</sub> 15%*	24V DC, -15%...+20% W <sub>SS</sub> 15%*
<b>Digital Inputs</b>					
Number of Digital Inputs	16 safety*	8 safety*	16 safety*	20 safety*	—
Voltage, On-State Input, Nom.	24V DC	24V DC	24V DC	24V DC	—
<b>Digital Outputs</b>					
Number of Digital Outputs	—	8 positive-switching and 2 negative-switching safety *	8 positive-switching and 8 negative-switching safety *	8 safety*	16 safety*
Current, On-State Output, per Channel	—	L+ Channels 1...3, 5...7: 0.5 A @ 60 °C (140 °F) L+ Channels 4 and 8: 1 A @ 60 °C (140 °F), 2 A @ 40 °C (104 °F) L- Channels 1 and 2: 1 A @ 60 °C (140 °F), 2 A @ 40 °C (104 °F)	Channels 2, 4, 5 and 7: 0.5 A @ 60 °C (140 °F) Channels 1 and 8: 1 A @ 60 °C (140 °F), 2 A @ 40 °C (104 °F) Channels 3 and 6: 1 A @ 60 °C (140 °F)	Channels 1...3, 5...7: 0.5 A @ 60 °C (140 °F) Channels 4 and 8: 1 A @ 60 °C (140 °F), 2 A @ 50 °C (122 °F)	1 A @ 60 °C (140 °F) 2 A @ 40 °C (104 °F)
Voltage, On-State Output, Max.	—	Supply Voltage (L+)	Supply Voltage (L+)	Supply Voltage (L+)	Supply Voltage (L+)
<b>Pulse Test Sources</b>					
Number of Pulse Test Sources	4*	2*	2*	—	—
<b>General</b>					
Temperature, operating	0...60 °C (32...140 °F)	0...60°C (32...140°F)	0...60°C (32...140°F)	0...60°C (32...140°F)	0...60 °C (32...140 °F)
Temperature, nonoperating	-40...85 °C (-40...185 °F)	-40...85 °C (-40...185 °F)	-40...85 °C (-40...185 °F)	-40...85 °C (-40...185 °F)	-40...85 °C (-40...185 °F)
Dimensions (HxWxD), Metric	114 x 152 x 78 mm‡	114 x 152 x 78 mm‡	114 x 205 x 100 mm‡	114 x 207 x 78 mm‡	114 x 207 x 78 mm‡
Dimensions (HxWxD), Imperial	4.49 x 5.99 x 3.07 in‡	4.49 x 6.00 x 3.07 in‡	4.49 x 8.08 x 3.94 in‡	4.49 x 8.16 x 3.07 in‡	4.49 x 8.16 x 3.07 in‡

\* Requires a power supply with protective separation, conforming to IEC 61131-2 requirements.

‡ Not electrically isolated.

‡ Height including latch; width including housing screws; depth including grounding bolt and connectors.

## Digital Relay Safety Output Module Specifications

Cat. No.	1753-OW8
Description	GuardPLC Digital Relay Output Module
Number of Outputs	8 safety relay
Operating Voltage Range	24V DC, -15%...+20% $w_{SS}$ 15%*
Switching Voltage	5...250 V AC/ DC
Switching Current	<ul style="list-style-type: none"> <li>• UL: 24V DC @ 1A resistive load, 250V AC @ 6 A general purpose</li> <li>• TUV: up to 240VA (for V AC), up to 30V DC @ 90 W, up to 70V DC @ 35 W, up to 127V DC @ 30 W</li> </ul>
Service Life, Mechanical	≥10 <sup>6</sup> switching cycles
Temperature, operating	0...60 °C (32...140 °F)
Temperature, nonoperating	-40...+85 °C (-40...+185 °F)
Dimensions (HxWxD), Metric	114 x 207 x 98 mm*
Dimensions (HxWxD), Imperial	4.49 x 8.16 x 3.86 in*

‡ External fusing adapted.

\* Requires a power supply with protective separation, conforming to IEC 61131-2 requirements.

\* Height including latch; width including housing screws; depth including grounding bolt and connectors.

## Analog Safety I/O Module Specifications

Cat. No.	1753-IF8XOF4
Description	GuardPLC Analog Combination Module
Operating Voltage Range	24V DC, -15%...+20%, $w_{SS}$ 15%*
Number of Safety Analog Inputs	8
Input Signal Range	Nominal: 0...+10V DC or 0...20 mA (with shunt) Service: -0.1...+11.5V DC or -0.4...23 mA (with shunt)
Input Impedance	Analog Input: >2 MΩ
Input Resolution	12 bit
Accuracy	0.5%
Number of Analog Outputs (Standard)	4‡
Output Signal Range	4...20 mA 0...20 mA
Output Impedance	Current Output: 600 Ω max.
Temperature, operating	0...60°C (32...140°F)
Temperature, nonoperating	-40...85 °C (-40...185 °F)
Dimensions (HxWxD), Metric	114 x 207 x 111 mm*
Dimensions (HxWxD), Imperial	4.49 x 8.16 x 4.37 in*

‡ Non-safety-related with common safety switch-off.

\* Requires a power supply with protective separation, conforming to IEC 61131-2 requirements.

\* Height including latch; width including housing screws; depth including grounding bolt, connectors, and shield plate.

# GuardPLC™ Safety Control Systems

## RXLogix Guard PLUS! Programming Software

### RSLogix Guard PLUS! Programming Software

Development and testing of programs for all GuardPLC systems is done with RSLogix Guard PLUS! programming software, an easy to use yet highly powerful programming software. RSLogix Guard PLUS! software is project-based, meaning you can store programs for multiple controllers in one project.

RSLogix Guard PLUS! is based on graphical function blocks. Simply design your logic using pre-defined elements such as AND-gates, OR-gates, numerical functions, etc., then connect inputs and outputs using the mouse. RSLogix Guard PLUS! software offers unlimited data tags, program pages, and function blocks for maximum flexibility.

Once RSLogix Guard PLUS! software has been configured for the chosen controller, input and output variables are defined in a tag list to establish the link between hardware and software in a manner similar to that used by ControlLogix controllers and RSLogix 5000 programming software.

To save time and decrease development effort, the offline program simulation allows you to test your program without downloading it to a GuardPLC controller. Online program monitoring allows you to view your logic inside the controller to see which parts are logically true and false and to troubleshoot as necessary.

### RSLogix Guard PLUS! Programming Software Examples

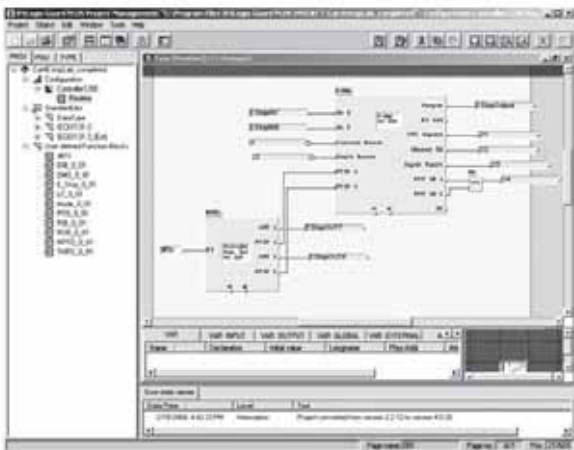

Use the project management screen to write a program, perform offline program simulation, and view the program running online.

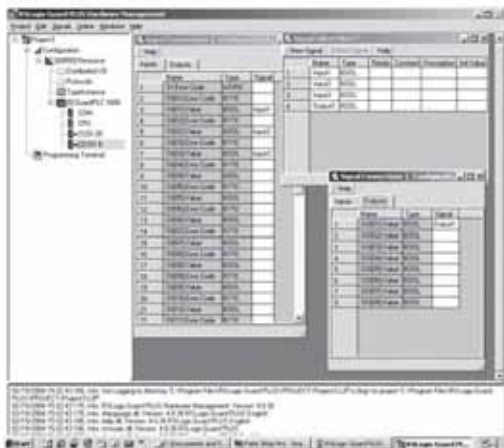

The hardware management screen within RSLogix Guard PLUS! lets you configure the hardware of your GuardPLC system, create tags, and then drag them into your program.

### Benefits

- Ease of use – program your safety control system using pre-defined graphical elements and a "drag and drop" palette.
- Tag-based system – define program variables to suit specific application and use variable names.
- Offline program simulation – test your program without using the controller.
- Online program monitoring – eases troubleshooting by viewing logic inside of GuardPLC controllers.
- Unlimited program pages and unlimited variables – configure program to suit specific needs.
- User-defined function blocks with library function – create your own specific instructions.
- Project-based controller linkage – store programs from multiple controllers in one project; ideal for cells that contain multiple GuardPLC controllers.
- Safety certified function blocks – save programming and configuration time by using function blocks that are already certified for use in safety applications.

### System Requirements

Requirements to install RSLogix Guard PLUS! programming software on a personal computer.

Requirements	Minimum	Recommended
Personal Computer	Pentium III, 500 MHz	Pentium IV, 1.2 GHz
Operating System	Windows NT/2000	Windows NT/2000/XP
RAM	256 MB	512 MB
Free Hard Disk Space	at least 200 MB plus space for user programs	at least 200 MB plus space for user programs
Resolution	1024 x 768/256 colors	1280 x 1024/true color

# GuardPLC™ Safety Control Systems

## RXLogix Guard PLUS! Programming Software/GuardPLC Hand-held Terminal

### RSLogix Guard PLUS! Programming Software

You can install RSLogix Guard PLUS! programming software on a local drive only (not a network).

Cat. No.	Description
1753-PCS-USB	RSLogix Guard PLUS! for all GuardPLC controllers. USB hardlock.
1753-PCS-PAR	RSLogix Guard PLUS! for all GuardPLC controllers. Parallel port hardlock.

### Certified Function Blocks for RSLogix Guard PLUS!

GuardPLC Certified Function Blocks are additional, application-specific instructions that can be used in your GuardPLC controller's application program. Certified by TÜV, these function blocks make application development, debugging, and troubleshooting quicker and easier. Certified Function Blocks are sold in suites or libraries that contain several blocks for specific applications.

Cat. No.	Description
1753-CFBBASIC	Basic Suite of Certified Function Blocks. Includes: E-stop, Diverse Input, Light Curtain, Two-hand Run Station, Enable Pendant, Redundant Output, and Pulse Test Output.

### GuardPLC OPC Server Software

GuardPLC OPC Server software allows a Windows-based PC to read data from and write data to the GuardPLC controller across the GuardPLC Ethernet network. For example, a VersaView computer could be running the GuardPLC OPC server and RSView software, then could display status information from the GuardPLC controller, such as which e-stop has been pressed, which gate is open, or which light curtain has been interrupted.

Cat. No.	Description
1753-OPC	GuardPLC OPC Server software

### GuardPLC Hand-held Terminal



The GuardPLC Hand-held Terminal is a maintenance tool that lets you commission new GuardPLC controllers and Distributed I/O modules by downloading configuration data and the application program. Store all of the programs for a project on a multimedia memory card, and connect to any GuardPLC device on the Ethernet network. The hand-held terminal is ideal for a downtime event that requires quick replacement of a GuardPLC controller or DIO block, helping to get production up and running again.

#### 1753-HHT Specifications

Operating Voltage Range	2.4...3.0V DC
Current Consumption	Approximately 360 mA (display illumination off) Approximately 560 mA (display illumination max)
Batteries	2 AA rechargeable batteries NiMH 2000 mAh or standard batteries
Operating Time, Min. with NiMH 2000 mAh batteries	Approximately 3 hours
Battery Charger, Supply Voltage	12V
Battery Charger, Current Input	≤ 0.83 A
Battery Charger, Charging Current	Approximately 1 A
Battery Charger, Trickle Charge	25 mA
Temperature, operating	5...55 °C (41...131 °F)
Temperature, nonoperating	-40...70 °C (-40...158 °F)
Relative Humidity	5...90% noncondensing
Vibration	5 g @ 10...500 Hz
Shock, operating	15 g
Dimensions (HxWxD), Metric	16.5 x 9 x 3 cm
Dimensions (HxWxD), Imperial	6.5 x 3.4 x 1.2 in
Weight, Metric	300 g
Weight, Imperial	0.66 lb

### GuardLogix Integrated Safety System Overview



A GuardLogix® controller is a full-function Logix processor that also provides safety control. The GuardLogix system is a dual processor solution that uses a primary controller and a safety partner to achieve SIL 3, PL e. A major benefit of this system is that it is a single project, with safety and standard control together. The GuardLogix system is a 1oo2 safety architecture that provides unmatched safety and ease of use.

Just like other Logix processors during development, safety and standard have the same rules. Online editing, forcing, even multiple users are all allowed. Once the project is tested and ready for final validation, you set the Safety Task to a SIL 3 integrity level, which is then enforced by the GuardLogix controller. When safety memory is locked and protected, the safety logic cannot be modified. On the standard side of the GuardLogix controller, all functions operate like a regular Logix controller, motion, drive, sequential, even process. Thus, online editing, forcing, and other activities are all allowed, while safety is securely isolated.

With this level of integration, safety memory can be read by standard logic and external devices, such as HMIs or other controllers, eliminating the need to condition safety memory for use elsewhere. The result is easy, system-wide integration and the ability to display safety status on displays or marquees. Use Guard I/O modules for field device connectivity on Ethernet or DeviceNet networks. For safety interlocking between GuardLogix controllers, use Ethernet or ControlNet networks. Multiple GuardLogix controllers can share safety data for zone-to-zone interlocking, or a single GuardLogix controller can use remote distributed safety I/O between different cells/areas.

### Features

In addition to the standard features of a Logix controller, GuardLogix controllers have these safety-related features.

Feature	1756-L61S, 1756-L62S, 1756-L63S, 1756-LSP		1768-L43S, 1768-L45S	
Communication options	Standard and safety <ul style="list-style-type: none"> <li>• EtherNet/IP</li> <li>• ControlNet</li> <li>• DeviceNet</li> </ul>		Standard <ul style="list-style-type: none"> <li>• EtherNet/IP</li> <li>• ControlNet</li> <li>• DeviceNet</li> </ul> Safety <ul style="list-style-type: none"> <li>• EtherNet/IP</li> <li>• ControlNet</li> </ul>	
Network connections, per network module	<ul style="list-style-type: none"> <li>• 256 EtherNet/IP; 128 TCP (1756-EN2x)</li> <li>• 128 EtherNet/IP; 64 TCP (1756-ENBT)</li> <li>• 100 ControlNet (1756-CN2/A)</li> <li>• 40 ControlNet (1756-CNB)</li> </ul>		<ul style="list-style-type: none"> <li>• 128 EtherNet/IP; 64 TCP (1768-ENBT)</li> <li>• 48 ControlNet (1768-CNB)</li> </ul>	
Controller redundancy	Not supported			
Programming languages	Standard control—all languages Safety control—relay ladder			

### Environmentals and Certifications

#### GuardLogix Controllers Environmental Specifications

	1756 GuardLogix Controllers	1768 Compact GuardLogix Controllers*
Operating temperature	0...60 °C (32...140 °F)	0...60 °C (32...140 °F)
Storage temperature	-40...85 °C (-40...185 °F)	-40...85 °C (-40...185 °F)
Relative humidity	5...95% noncondensing	5...95% noncondensing
Vibration	2 g at 10...500 Hz	5 g at 10...500 Hz
Operating shock	30 g	30 g
Nonoperating shock	50 g	50 g

\* 1768 Compact GuardLogix controller specification and certification listings are preliminary.

#### GuardLogix Controllers Certifications

Certifications: UL, c-UL-us, CE, CSA, C-Tick, FM, ATEX, certified by TÜV for Functional Safety.

When product is marked. See the Product Certification link at [www.ab.com/certification/ce](http://www.ab.com/certification/ce) to Declarations of Conformity, Certificates, and other certification details. For safety and SIL certification details, see [www.rockwellautomation.com/products/certification/safety/index.html](http://www.rockwellautomation.com/products/certification/safety/index.html).

### GuardLogix Controllers

Cat. No.	Description	User Memory		Module Expansion Capacity†
		Standard Tasks and Components	Safety Task and Components	
1756-L61S	GuardLogix safety controller	2 MB	1 MB	Not applicable
1756-L62S		4 MB	1 MB	
1756-L63S		8 MB	3.75 MB	
1756-LSP	GuardLogix safety partner*	—	—	
1768-L43S	Compact GuardLogix safety controller	2 MB	0.5 MB	1768 Modules: 2 1769 Modules: 16
1768-L45S		3 MB	1 MB	1768 Modules: 4 1769 Modules: 30

\* A safety partner is required for each 1756 GuardLogix controller.

† You can install any combination of motion and network modules in a 1768 system. A maximum of two network modules may be installed in a 1768 system.

Logic  
**GuardLogix® Integrated Safety Systems**  
 Overview/Controllers

**Example Configuration—1756 GuardLogix System**

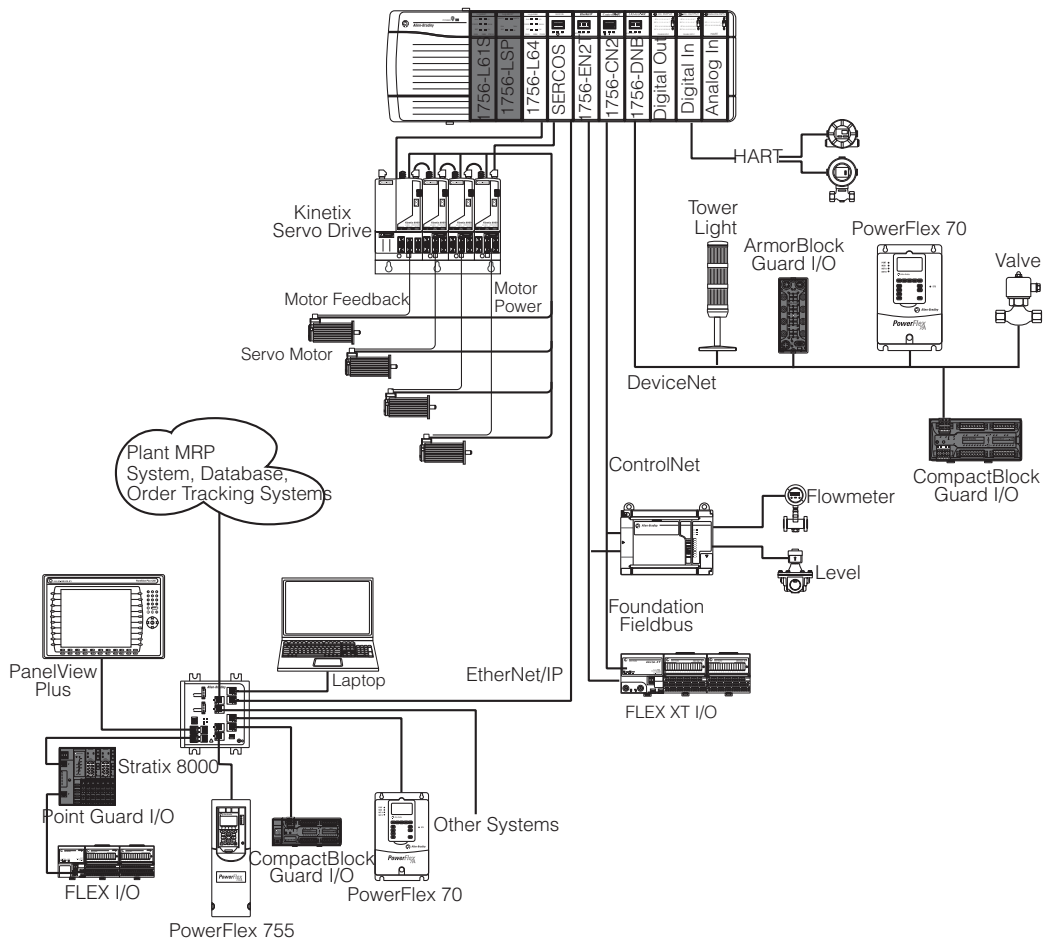

**Example Configuration—1768 Compact GuardLogix System**

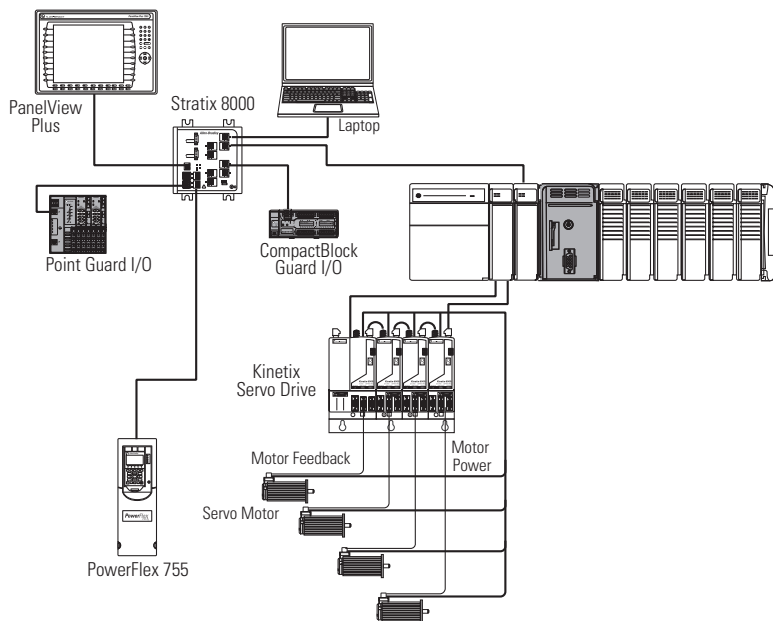

5-Programmable  
Safety Solutions

### Standard Components in a GuardLogix System

Virtually all standard components are approved for use in GuardLogix safety systems. For specific series or version supported, see [www.rockwellautomation.com/products/certification/safety/index.html](http://www.rockwellautomation.com/products/certification/safety/index.html).

For control that is not SIL 3 related, other 1756 series I/O modules can be used with 1756 GuardLogix controllers and 1768 or 1769 I/O modules can be used with 1768 Compact GuardLogix controllers. These modules must be certified to the Low Voltage and EMC Directives. Refer to [www.ab.com/certification/ce](http://www.ab.com/certification/ce) to find the certificate for the Programmable Control – ControlLogix or CompactLogix Product Families.

### Accessories

#### Replacement Batteries

	1756-BA2
Description	Lithium battery (0.59 g)
GuardLogix controllers	1756-L61S, 1756-L62S, 1756-L63S

#### Industrial CompactFlash Cards

CompactFlash cards offer nonvolatile memory (flash) to permanently store a user program and tag data on a controller. You install the 1784 CompactFlash card in a socket on the controller. You can manually trigger the controller to save to or load from nonvolatile memory or configure the controller to load from nonvolatile memory on power up.

1756 and 1768 GuardLogix controllers support user program storage or retrieval by using a CompactFlash card with version 18 or later of RSLogix 5000 software.

	1784-CF64	1784-CF128
Memory	64 MB	128 MB
Weight, approx.	14.2 g (0.5 oz)	

### Software

GuardLogix controllers use RSLogix™ 5000 programming software, the standard development environment for all Allen-Bradley Logix controllers. RSLogix 5000 software manages safety, so you don't have to manually manage the separation of standard and safety memory, or worry about partitioning logic to isolate safety.

FactoryTalk Suite from Rockwell Software extends the Rockwell Automation Integrated Architecture™ by providing an information tier of software applications and services for production and performance management. Tight integration with the Rockwell Automation Logix control platform, as well as connectivity to third-party and legacy systems can help deliver a seamless flow of high-fidelity data across your enterprise.

#### Safety-certified Instructions in RSLogix 5000 Software

All instructions available for use within the safety task are certified safety instructions. Choose from standard relay ladder safety instructions and safety application instructions, including:

- 49 safety-certified instructions
  - Subset of standard ladder logic instruction set
- Safety-certified application instructions
  - Dual channel suite - 6 instructions
  - Metalforming suite - 10 instructions
  - Muting suite - 3 instructions
  - Safety mat

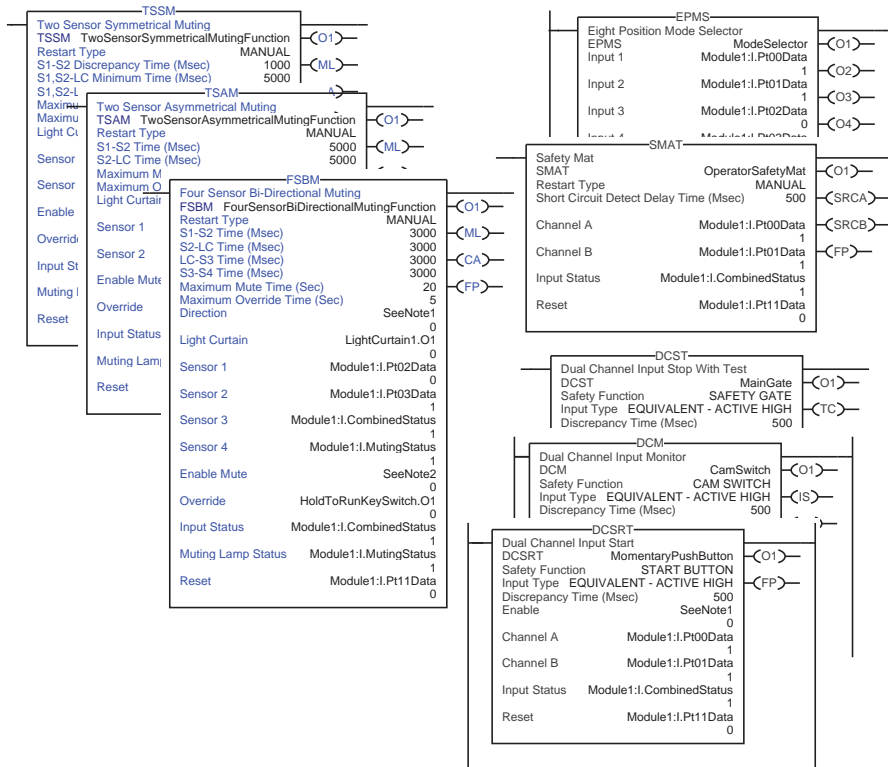

**Safety application instructions provide unmatched ease of use for complex safety functions like muting, safety gate control, metalforming, and more.**

**5-Programmable Safety Solutions**

# Guard I/O™ Modules

## Overview

### Guard I/O™ Modules Overview

Control and monitor your safety devices with Guard I/O. When used with Rockwell Automation safety controllers, Guard I/O communicates on EtherNet/IP or DeviceNet using CIP Safety protocol. As an effective technology, Guard I/O detects failures at the I/O and field device level, while helping enhance operator protection.

CompactBlock Guard I/O modules are available in IP20 (in-cabinet) form factor. ArmorBlock Guard I/O modules are IP64, IP65, or IP67 (on-machine) form factor (as marked on the product label). POINT Guard I/O provides maximum I/O density in minimal panel space.

Guard I/O modules offer the following advantages when implementing a safety control system:

- **Reduced engineering** — Onboard, Guard I/O has self-diagnostics, hardware testing, and field circuit testing (short-circuit, wire break, discrepancy) with no additional programming required.
- **Cost-reduced hardware options** — Helps increase ability to safely shutdown an application without additional safety relays.
- **Space-savings** — Monitor and control more safety devices using less panel space.
- **Use of existing network infrastructures** — Connect to standard and safety I/O over one DeviceNet or EtherNet/IP network.
- **Flexibility and easy migration to EtherNet/IP** — The same Guard I/O modules for both DeviceNet and EtherNet/IP networks lets you re-use engineering designs.
- **High safety level** — certified by TÜV for Functional Safety up to SIL 3 and PLe/Category 4.

### Common Guard I/O Module features:

- Integrated pulse test outputs for testing safety circuitry like e-stops and gate switches, for use in applications up to Performance Level e/Category 4. These outputs can also be used independently for standard output control or voltage source to sensors.
- Safety outputs, with integrated pulse testing for use in applications up to PLe, Cat.4.
- Ability to detect at each I/O point:
  - short-circuit to 24V DC or 0V
  - wire breakage
  - discrepancy of dual channel circuitry, due to mechanical alignment or a failure
- All Guard I/O modules have common circuit functionality, operation, programming, troubleshooting, and diagnostics.
- Built in diagnostic LEDs for I/O circuitry and power status.
- I/O point status available to any controller.
- EDS file or Logix 5000 profile compatible.
- Removable and keyed terminal blocks.
- Common power and I/O wiring across Guard I/O modules on DeviceNet and EtherNet/IP networks (1791DS-IB16/1791ES-IB16 and 1791DS-IB8XOBV4/1791ES-IB8XOBV4).
- Safety input power source separate from safety output power source.
- Removable and insertable under power, when following appropriate safety practices.
- Electronic overcurrent protection of all outputs.

	 CompactBlock Guard I/O Modules	 ArmorBlock Guard I/O Modules	 POINT Guard I/O Modules
<b>Description</b>	Cost-effective block I/O for use in an enclosure.	Cost-effective block I/O with IP64, IP65, or IP67 protection (as indicated on the product label) for use on the machine.	Cost-effective I/O modules provide maximum I/O density in minimum panel space.
<b>Digital Safety Inputs</b>	Up to 16 channels	Up to 8 channels	Up to 8 channels
<b>Digital Safety Outputs</b>	Up to 8 channels	Up to 4 channels	Up to 8 channels
<b>Safety Relays</b>	Up to 4 channels (1791DS)	No	No
<b>High Current Capacity Outputs</b>	Up to 2 amps per channel	Up to 2 amps per channel	Up to 1 amp per channel
<b>Use in Hazardous Areas</b>	UL Listed for Class I, Division 2 Group A,B,C,D	No	UL Listed for Class I, Division 2 Group A,B,C,D; ATEX
<b>DeviceNet</b>			
<b>Interface Module</b>	1756-DNB, 1753-DNSI, 1752	1756-DNB, 1753-DNSI, 1752	1734-PDN
<b>Bulletin Number</b>	1791DS	1732DS	1734
<b>EtherNet/IP</b>			
<b>Interface Module</b>	1756-ENBT, 1756-EN2T, 1756-EN2F	Not available	1734-AENT, 1734-AENTR
<b>Bulletin Number</b>	1791ES	Not available	1734

Typical Configurations

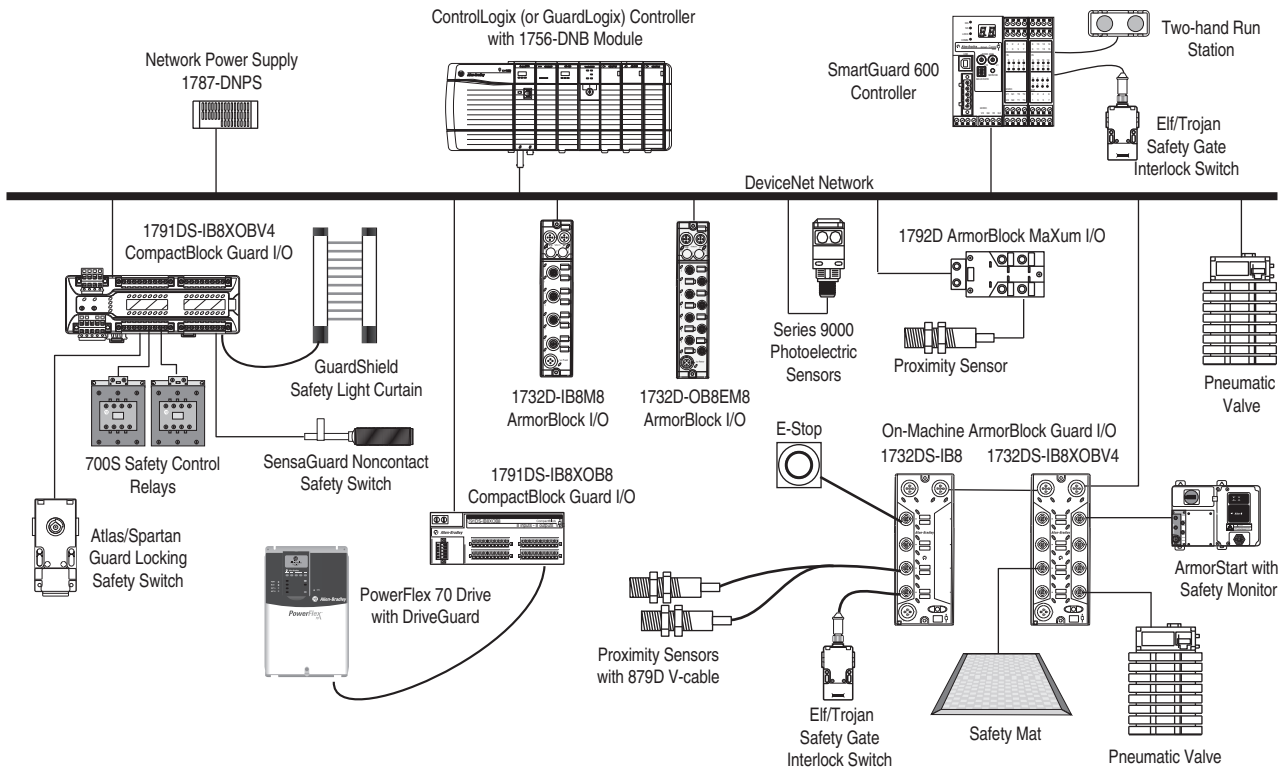

The above example network shows how almost any 24V DC safety-rated or standard sensor can be wired to any Guard I/O module to monitor the machine's status.

Choosing Your I/O Hardware

Guard I/O module options are available to minimize associated safety hardware. Additionally, installation costs, wiring time, and commissioning time can be further reduced when using ArmorBlock Guard I/O, as shown in the example below with a light curtain muting application.

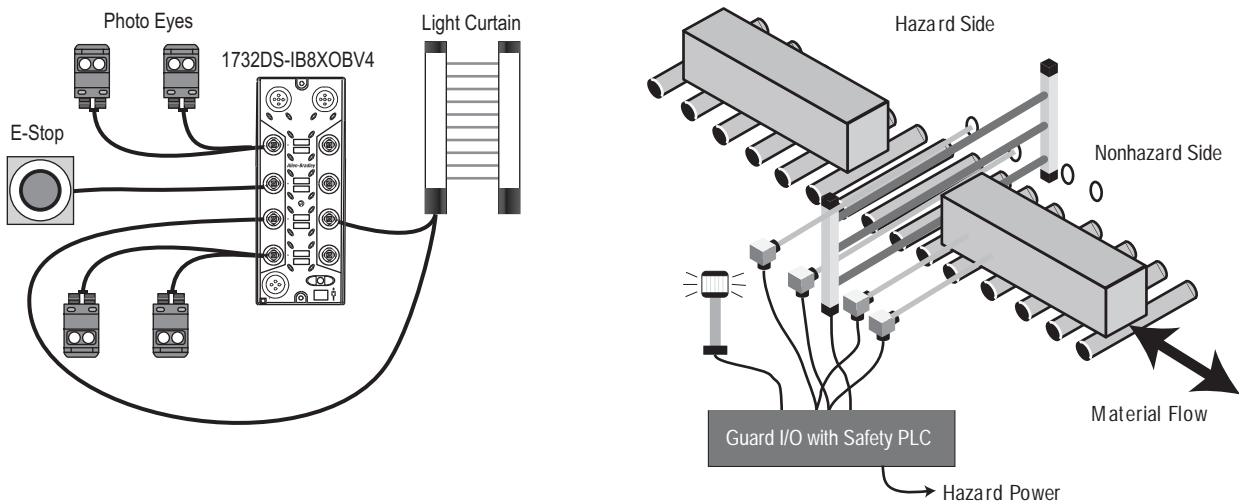

5-Programmable  
Safety Solutions

## Guard I/O™ Modules

### Overview/CompactBlock Guard I/O

A variety of CompactBlock Guard I/O is available to suit most every need.

- **1791DS-IB8XOB8 Module.** This module has up to 8 single channel safety inputs and 8 single channel safety outputs. It is often the universally chosen Guard I/O hardware for almost every application. Whether you need single or dual channel safety input or safety output circuits, the 1791DS-IB8XOB8 module is a good choice.
- **1791DS-IB4XOW4 Module.** This module has up to 4 single channel safety inputs and 4 single channel (replaceable) safety relay outputs. This module is often chosen for AC actuators or specialty safety interface applications. Whether you need single or dual-channel safety input or safety output circuits, the 1791DS-IB4XOW4 module is a good choice.
- **1791DS-IB8XOBV4 or 1791ES-IB8XOBV4 Modules.** These modules have up to 8 single channel safety inputs and 4 dual channel sink/source safety outputs, also known as bipolar or two-pole switching. They are often chosen for safety actuators that require more than 0.5 amps. For example, the control of press safety valves or control of the solenoid on a guard-locking switch like the Atlas or Trojan safety products. Whether you need single or dual channel safety input circuits and dual channel safety outputs, the 1791DS-IB8XOBV4 or 1791ES-IB8XOBV4 module will suit most any application.
- **1791DS-IB16 or 1791ES-IB16 Modules.** These modules have up to 16 single channel safety inputs. They are the universal choice of Guard I/O hardware when an application calls for the monitoring of many safety devices in one central location. When your safety application requires 2 safety mats, 2 run stations with 2 e-stops, or any similar configuration, these modules are an excellent and economical choice for every programmable safety system.

### CompactBlock™ Guard I/O™



#### Description

CompactBlock Guard I/O provides all the advantages of traditional distributed I/O for safety systems. Distributed safety I/O reduces wiring costs and startup time for machines and cells, as compared to in-chassis I/O. You can use Guard I/O with any safety controller that communicates on DeviceNet or EtherNet/IP networks using CIP Safety, for the control and monitoring of safety circuits. Guard I/O detects circuit failures at each I/O point while providing detailed diagnostics directly to the controller. With CIP Safety you can easily integrate safety and standard control systems by using safety and standard messages on the same wire.

Several Guard I/O blocks are available with a variety of features:

- The 1791DS CompactBlock Guard I/O family consists of 24V DC digital I/O modules that communicate on DeviceNet networks.
- The 1791ES CompactBlock Guard I/O family consists of 24V DC digital I/O modules that communicate on EtherNet/IP networks.

#### Benefits

- TÜV Certified as a system with GuardLogix, GuardPLC 1600 and 1800, and SmartGuard 600 controllers
- Supports both standard and safety control
- I/O point-level and other detailed fault diagnostics are available to the PLC or HMI, with the self testing inputs and outputs
- EDS (RSNetWorx for DeviceNet) or RSLogix 5000 profile configuration
- Certified by TÜV for Functional Safety up to SIL 3 according to IEC 61508, and Category 4, PLe according to ISO 13849-1
- Supports single and dual channel devices on inputs and outputs
- Additional standard solid-state outputs that can be configured as pulse test sources, outputs for standard PLC control, 24V DC sources, or for muting lamp control and monitoring
- DIN Rail mounting for easy installation
- Compatible with Guardmaster and similar safety devices

**CompactBlock Guard I/O DeviceNet Safety Module Specifications**

Cat. No.	1791DS-IB12	1791DS-IB16	1791DS-IB8XOB8	1791DS-IB8XOBV4	1791DS-IB4XOW4
Description	24V DC Input Module on DeviceNet Networks	24V DC Input Module on DeviceNet Networks	24V DC Input/Solid-State Output Module on DeviceNet Networks	24V DC Input/Output Module on DeviceNet Networks	24V DC Input / Relay Output Module for DeviceNet Networks
Current Consumption	110 mA @ 24V DC	85 mA @ 24V DC	110 mA @ 24V DC	85 mA @ 24V DC	110 mA @ 24V DC
Operating Voltage Range	20.4...26.4V DC (24V DC, -15...+10%)	19.2...28.8V DC (24V DC, -20...+20%)	20.4...26.4V DC (24V DC, -15...+10%)	19.2...28.8V DC (24V DC, -20...+20%)	20.4...26.4V DC (24V DC, -15...+10%)
<b>Digital Inputs</b>					
Number of Inputs (single-channel)	12 safety	16 safety	8 safety	8 safety	4 safety
Input Type	current sinking	current sinking	current sinking	current sinking	current sinking
Voltage, On-State Input, Min.	11 V DC	11 V DC	11 V DC	11V DC	11V DC
Voltage, Off-State Input, Max.	5V DC	5V DC	5V DC	5V DC	5V DC
Current, On-State Input, Min.	6 mA	3.3 mA	6 mA	3.3 mA	6 mA
<b>Digital Outputs</b>					
Number of Outputs	—	—	8 single-channel, safety solid-state	4 dual channel, safety solid-state	4 single-channel, safety relay
Output Type	—	—	current sourcing	current sourcing/current sinking	relay
Output Current Rating	—	—	0.5 A per point	2.0 A continuous	2 A max. per contact
Output Leakage Current, Max.	—	—	0.1 mA	± 1.0 mA	—
Service Life, Electrical	—	—	—	—	100 000 operations, min.
Short Circuit Protection	—	—	Yes	Yes	No
<b>Standard Pulse Test Outputs</b>					
Number of Pulse Test Sources	4	16	4	8	4
Pulse Test Output Current	0.7 A per point	0.7 A per point	0.7 A per point	0.7 A per point	0.7 A per point
Short Circuit Protection	Yes	Yes	Yes	Yes	Yes
<b>General</b>					
Temperature, operating	-10...55° C (14...131 °F)	-20°C...+60°C (-4°F...+140°F)	-10...55° C (14...131 °F)	-20°C...+60°C (-4°F...+140°F)	-10...55° C (14...131 °F)
Relative Humidity	5...95% noncondensing	5...95% noncondensing	10...95% noncondensing	5...95% noncondensing	10...85% noncondensing
Vibration	5 g @ 57...150 Hz	5 g @ 10...500 Hz	5 g @ 57...150 Hz	5 g @ 10...500 Hz	5 g @ 57...150 Hz
Shock, operating	15 g	30 g	15 g	30 g	10 g
Enclosure Protection	IP20	IP20	IP20	IP20	IP20
Dimensions (HxWxD), Metric	68 x 170 x 72 mm*	81 x 170 x 76 mm*	68 x 170 x 72 mm*	81 x 170 x 76 mm*	95 x 170 x 83 mm*
Certifications†	UL, CE, C-Tick, CSA, UL Class I Div 2 Hazardous, UL NRGF, ODVA Conformance, certified by TÜV for Functional Safety up to SIL 3 and Cat. 4, PLe	UL, CE, C-Tick, CSA, UL Class I Div 2 Hazardous, ODVA Conformance, certified by TÜV for Functional Safety up to SIL 3 and Cat. 4, PLe	UL, CE, C-Tick, CSA, UL Class I Div 2 Hazardous, UL NRGF, ODVA Conformance, certified by TÜV for Functional Safety up to SIL 3 and Cat. 4, PLe	UL, CE, C-Tick, CSA, UL Class I Div 2 Hazardous, ODVA Conformance, certified by TÜV for Functional Safety up to SIL 3 and Cat. 4, PLe	UL, CE, C-Tick, CSA, UL NRGF, ODVA Conformance, TÜV certified for functional safety up to SIL 3 and Cat. 4, PLe

\* Includes DIN latch and connectors.

† When product is marked. See the Product Certification link at <http://www.ab.com/certification> for Declarations of Conformity, Certificates, and other certification details.

All specifications are subject to change. Refer to product installations instructions.

## CompactBlock Guard I/O EtherNet/IP Safety Module Specifications

Cat. No.	1791ES-IB16	1791ES-IB8XOBV4
Description	24V DC Input Module on EtherNet/IP	24V DC Input/Output Module on EtherNet/IP
Current Consumption	250 mA @ 24V DC	250 mA @ 24V DC
Operating Voltage Range	19.2...28.8V DC (24V DC, -20...+20%)	19.2...28.8V DC (24V DC, -20...+20%)
<b>Digital Inputs</b>		
Number of Inputs	16 single channel; 8 dual channel	8 single channel; 4 dual channel
Input Type	current sinking	current sinking
Voltage, On-State Input, Min.	11 V DC	11 V DC
Voltage, Off-State Input, Max.	5V DC	5V DC
Current, On-State Input, Min.	3.3 mA	3.3 mA
<b>Digital Outputs</b>		
Number of Outputs	0	4 dual channel
Output Type	—	Current sourcing/current sinking - bipolar pair
Output Current Rating	—	2.0 A continuous
Short Circuit Protection	Yes	Yes
<b>Standard Pulse Test Outputs</b>		
Number of Pulse Test Sources	16 current sourcing	8 current sourcing
Pulse Test Output Current	0.7 A per point	0.7 A per point
Short Circuit Protection	Yes	Yes
<b>General</b>		
Temperature, operating	-20...60° C (-4...140° F)	-20...60° C (-4...140° F)
Relative Humidity	5...95% noncondensing	5...95% noncondensing
Vibration	5 g at 10...500 Hz	5 g at 10...500 Hz
Shock, operating	30 g	30 g
Enclosure Protection	IP20	IP20
Dimensions (HxWxD), Metric	80 x 196 x 77 mm*	80 x 196 x 77 mm*
Certifications†	cULus, CE, C-Tick, CSA, UL Class I Div 2 Hazardous, UL NRGF, ODVA Conformance, certified by TÜV and UL for Functional Safety up to SIL 3 and Cat. 4, PLe	cULus, CE, C-Tick, CSA, UL Class I Div 2 Hazardous, UL NRGF, ODVA Conformance, certified by TÜV and UL for Functional Safety up to SIL 3 and Cat. 4, PLe

\* Includes terminal block.

† When product is marked. See the Product Certification link at <http://www.ab.com/certification> for Declarations of Conformity, Certificates, and other certification details.

All specifications are subject to change. Refer to product installations instructions.

ArmorBlock® Guard I/O™



Description

ArmorBlock® Guard I/O™ provides all the advantages of traditional distributed I/O for safety systems, but has an IP64, IP65, or IP67 package (as marked on the product label) that can be mounted directly on your machine. On-machine safety I/O reduces wiring time and startup costs for safety controller applications by eliminating electrical boxes and simplifying cable installation. The ArmorBlock family provides industrially hardened I/O blocks that you can mount directly on equipment near sensors or actuators. Wiring the I/O to the sensors and actuators is easy using pre-wired quick disconnect cables.

You can use Guard I/O with any safety controller that communicates on DeviceNet using CIP Safety for the control and monitoring of safety circuits. Guard I/O detects circuit failures at each I/O point while providing detailed diagnostics directly to the controller. With CIP Safety, you can easily integrate safety and standard control systems by using safety and standard messages on the same wire.

The 1732DS ArmorBlock Guard I/O family consists of 24V dc digital I/O modules that communicate on DeviceNet networks. The I/O connectors are sealed M12 micro style while the network and auxiliary power connectors are sealed mini style. Plus, the ArmorBlock Guard I/O uses the same input and output M12 pin configuration as standard ArmorBlock and Maxum.

Benefits

- IP64, IP65, or IP67 rated for direct mounting on machine without an enclosure (rating is marked on the product label)
- Compact footprint
- Quick disconnect dual-channel M12 I/O connectors allow a single cable connected between ArmorBlock Guard I/O and a dual-channel safety device (See the following table of Allen-Bradley Guardmaster safety devices)
- TÜV certified as a system with GuardLogix, GuardPLC1600/1800, SmartGuard 600 controllers
- Supports both standard and safety control
- Supports single and dual-channel devices on inputs and outputs
- I/O point-level and other detailed fault diagnostics are available to the PLC or HMI with self-testing inputs and outputs
- EDS (RSNetWorx for DeviceNet) or RSLogix 5000 profile configuration
- Certified by TÜV and UL for Functional Safety up to SIL 3 according to IEC 61508, and PLe/Category 4, according to ISO 13849-1
- Additional standard solid-state outputs can be configured as pulse test sources, outputs for standard PLC control, 24V dc sources, or muting lamp control and monitoring

Specifications

Cat. No.	1732DS-IB8	1732DS-IB8XOBV4
Description	24V DC Input Module for DeviceNet Networks	24V DC Input/Output Module on DeviceNet Networks
Current Consumption	85 mA @ 24V DC	
I/O Operating Voltage Range	19.2V...28.8 V DC (24V DC, -20...+20%)	
<b>Digital Inputs</b>		
Number of Inputs	8 safety single-channel or 4 safety dual-channel	
Input Type	current sinking	
Voltage, On-State Input, Min.	11V DC	
Voltage, Off-State Input, Max.	5V DC	
Current, On-State Input, Min.	3.3 mA	
<b>Digital Outputs</b>		
Number of Outputs	—	4 safety solid-state
Output Type	—	dual channel, current sourcing/current sinking pair
Output Current Rating	—	2.0 A max per point
Short Circuit Protection	—	Yes
<b>Standard Pulse Test Outputs</b>		
Number of Pulse Test Sources	8	
Pulse Test Output Current	0.7 A per point	
Short Circuit Protection	Yes	
<b>General</b>		
Temperature, operating	-20°...+60°C (-4°C...+140°F)	
Relative Humidity	10...95% non-condensing	
Vibration	0.76 mm @ 10...500 Hz	
Shock, operating	30 g	
Enclosure Protection	IP64, IP65, or IP67 as marked on the product label	
Dimensions (HxWxD), Metric	179 x 70 x 68.7 mm*	
Dimensions (HxWxD), Imperial	7.05 x 2.76 x 2.71 in*	
Weight, Metric	600 g	
Weight, Imperial	1.2 lb	
Certifications*	UL, CE, C-Tick, CSA, UL NRGF, ODVA Conformance, certified by TÜV for Functional Safety up to SIL 3 and PLe/Cat. 4	

\* Includes terminal block.

\* When product is marked. See the Product Certification link at <http://www.ab.com/certification> for Declarations of Conformity, Certificates, and other certification details.

All specifications are subject to change. Refer to product installations instructions.

**Safety Products that Connect Directly to ArmorBlock Guard I/O with a Single 5-Pin Micro (M12) Patchcord\***



Product Family	Actuator Type	Cat. No. (with M12)	Catalog Page
Elf	Flat	440K-E2NNFPS	3-11
	Semi-flexible	440K-E2NNAPS	3-11
Cadet	Flat	440K-C2NNFPS	3-15
	Semi-flexible	440K-C2NNAPS	3-15
Trojan T15	Standard	440K-V2NNSPS	3-19
	Fully-flexible	440K-V2NNBPS	3-19
Trojan T15-GD2	GD2 Standard	440K-V2NNGPS	3-19
Trojan T5	Standard	440K-T2NBSPS	3-23
	Fully-flexible	440K-T2NBBPS	3-23
Trojan T5-GD2	GD2 Standard	440K-T2NBGPS	3-23
MT-GD2, Case Color Red with Snap-acting Contacts	None	440K-M2NBDS	3-29
	None	440K-M2NANDS	3-29
MT-GD2, Case Color Yellow, Snap-acting Contacts	None	440K-M2NANYS	3-29
Sprite	Solid - 50xØ10 mm	440H-S2NNPPS	3-91
	Pre-bored - 30xØ16 mm	440H-S2NNHPS	3-91
Ensign	Solid - 50xØ10 mm	440H-E2NNPPS	3-95
	Pre-bored - 30xØ16 mm	440H-E2NNHPS	3-95
Lifeline3	N/A	440E-D2NNNYS	[S-3503977]
Lifeline4	N/A	440E-L2NNNYS	4-11
Emergency Stop	N/A	800F-1YMQ53V	4-43
Safety Mats	N/A	440F-MxxxHxNN	2-94

\* Only the 2 N.C. safety contacts of the safety switches are connected to the 5-pin micro (M12) connector.

**1732DS ArmorBlock Guard I/O Micro Connector Pin Assignments**

Input Configuration		Female	Output Configuration	
Pin	Signal		Pin	Signal
1	Test Output n+1		1	Output +24V dc Power
2	Safe Input n+1		2	Output n+1 (Sinking)
3	Input Common		3	Output Power Common
4	Safe Input n		4	Output n (Sourcing)
5	Test Output n		5	Output Power Common

**1732DS ArmorBlock Guard I/O Mini Connector Pin Assignments**

ArmorBlock Guard I/O DeviceNet Configuration			
Pin	Signal	Male	Female
1	Drain		
2	V+ (Red)		
3	V- (Black)		
4	CAN_H (White)		
5	CAN_L (Blue)		

ArmorBlock Guard I/O Power Configuration		
Pin	Signal	Male
1	Output +24V dc Power (Red)	
2	Input +24V dc Power (Green)	
3	Input Power Common (White)	
4	Output Power Common (Black)	

**ArmorBlock Guard I/O Recommended Compatible Cables and Connectors\***

Description	Cat. No.
 DC Micro (M12) Male Cordset	889D-M5AC-⌘
 DC Micro Style Patchcord	889D-F5ACDM-‡
 DC Micro V-Cable for Single-Channel Sensors	879D-F4ACD5M-§
 M12 Single-Channel Splitter	879D-F4D5M
 M12 Terminal Chamber—Straight Male	871A-TS5-DM
 M12 Terminal Chamber—Right Angle Male	871A-TR5-DM

\* All cables must use 5-pin connections for ArmorBlock Guard I/O M12 input compatibility.  
 ⌘ Replace symbol with 0M3 (0.3 m), 2 (2 m), or 5 (5 m) for standard cable length.  
 ‡ Replace symbol with 1 (1 m), 2 (2 m), 5 (5 m), or 10 (10 m) for standard cable length.  
 § Replace symbol with 0M3 (0.3 m), 1 (1 m), 2 (2 m), or 5 (5 m) for standard cable length.

5-Programmable  
Safety Solutions

# Guard I/O™ Modules

## ArmorBlock Guard I/O

### Single Channel Wiring (879D-F4ACD5M and 1485P-PID5-RR4)

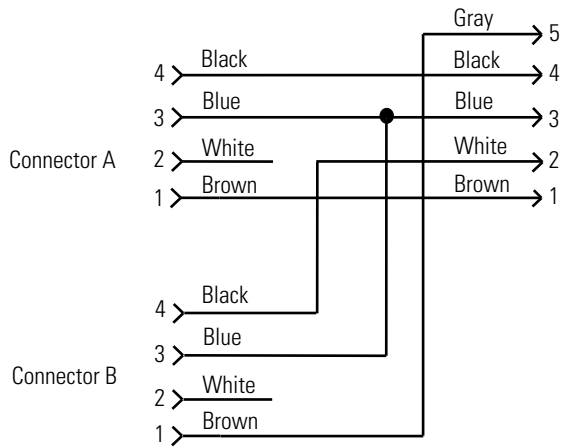

**POINT Guard I/O™**



**Description**

POINT Guard I/O™ modules are safety-rated I/O modules designed to fit into the standard POINT I/O system, offering automation and safety functionality in a maximum density I/O solution. They are ideal for use in applications requiring safety and automation control. They communicate by using CIP Safety protocol over EtherNet/IP for GuardLogix controllers or DeviceNet for SmartGuard safety controllers. The application of CIP Safety protocol allows simultaneous transmission of safety and automation control and diagnostic data over one CIP network.

POINT Guard I/O and POINT I/O can be controlled by one GuardLogix controller for both safety and automation control through one node. If separate safety control is required, a GuardLogix controller can be used with POINT Guard I/O for safety control and a ControlLogix controller can be used with POINT I/O for automation control. No changes are required to the POINT I/O system.

This solution is ideal for applications requiring maximum I/O density in minimum panel space. The advanced solid-state design allows for module replacement in minutes and helps reduce the need for special maintenance or training.

POINT Guard I/O is designed for use with industrial equipment and is especially suited for robotic, point-of-operation, guard-monitoring, and distributed control applications.

**Benefits**

- Mix safety inputs and outputs with standard POINT I/O, all with one node
- Maximum I/O density in minimum panel space
- Simple to add to existing panels using POINT I/O
- I/O point-level diagnostics quickly identify problems and reduce downtime
- Easy configuration by using RSLogix 5000 with full support of IP addressing
- Optimize installations by assigning individual test output for safety input device
- Connect single and dual-channel safety devices on inputs and outputs
- Certified by TÜV for Functional Safety up to SIL 3 according to IEC 61508, and PLe/Category 4, according to ISO 13849-1
- Muting lamp control and monitoring on selected test pulse outputs

**Networking with POINT Guard I/O™**

POINT Guard I/O™ modules are used in the POINT I/O platform and can communicate safety messages via network adapters to connect to EtherNet/IP or DeviceNet networks. Use these adapters for network communication.

Network	System	Adapter*
EtherNet/IP	GuardLogix	1734-AENT
		1734-AENTR
DeviceNet	SmartGuard 600	1734-PDN

\* Not compatible with 1734-ADN, 1734-ADNX, 1734-AP, or 1734-ACNR adapters.

**Specifications**

Cat. No.	1734-IB8S	1734-OB8S
Description	Point I/O 24V DC 8 Input Safety Module	Point I/O 24V DC 8 Output Safety Module
PointBus Current (mA), Max.	175	190
Operating Voltage Range	19.2...28.8V DC	19.2...28.8V DC

**Digital Inputs**

Number of Inputs	8	—
Input Type	Current Sinking	—
Voltage, On-State Input, Min.	11V DC	—
Voltage, Off-State Input, Max.	5V DC	—
Current, On-State Input, Min.	3.3 mA	—
Input Delay Time, Off to On	16.2 ms max	—
Input Delay Time, On to Off	—	—

**Digital Outputs**

Number of Outputs	—	8
Output Type	—	Current Sourcing
Output Current Rating, Max.	—	1 A max per point
Leakage Current, Off-State Output, Max	—	0.1 mA
Output Delay Time, Off to On, Max.	—	6.2 ms‡
Output Delay Time, On to Off, Max.	—	6.2 ms§
Short Circuit Protection	—	Yes, Electronic
Overcurrent Detection	—	Yes

**Standard Pulse Test Outputs**

Number of Pulse Test Sources	4	—
Pulse Test Output Current	0.7A per point	—
Pulse Test Output Leakage Current, Max.	0.1 mA	—
Short Circuit Protection	Yes	—

**General**

Temperature, operating	-20...55 °C (-4...131 °F)
Temperature, nonoperating	-40...85 °C (-40...185 °F)
Relative Humidity	5...95% noncondensing
Vibration	5 g at 10...500 Hz
Shock, operating	30 g
Enclosure Protection	IP20
Dimensions (HxWxD), Metric	77.0 x 25.0 x 55.0 mm*
Dimensions (HxWxD), Imperial	3.03 x 0.98 x 2.17 in*
Weight, Metric	62.4 g
Weight, Imperial	2.2 oz

Certifications\* CE, C-Tick, CSA, ODVA Conformance, certified by TÜV for Functional Safety up to SIL 3 and PLe/Cat. 4

**Note:** All specifications are subject to change. Refer to product installations instructions.

\* Includes terminal block.

‡ When product is marked. See the Product Certification link at <http://www.ab.com/certification> for Declarations of Conformity, Certificates, and other certification details.

‡ Off/on delay is time from a valid output "on" signal to output energization.

§ On/off delay is time from a valid output "off" signal to output deenergization.

